

PAPI
Style A
Type L-880, Type L-881
Instruction Manual

Revision 2.0

June 7, 2016

Precision Approach Path Indicator

In accordance with:

FAA

Advisory Circular AC-150/5345-28G

Manufactured by:
Airport Lighting Company
108 Fairgrounds Drive
Manlius, New York 13104
(315) 682-6460
Info@airportlightingcompany.com



THIS MANUAL COVERS STYLE A, VOLTAGE POWERED PAPI SYSTEMS ONLY

GUARANTEE

Airport Lighting Company guarantees that the equipment manufactured by Airport Lighting Company and covered by this manual has been manufactured and will perform in accordance with applicable specifications. Any defect in design, materials (excluding lamps,) or workmanship which may occur during proper and normal use during a period of 1 year from date of installation or a maximum of 2 years from date of shipment will be corrected by repair or replacement by Airport Lighting Company, with transportation costs borne by the purchaser. This guarantee covers PAPI systems, 880-V-2 series, 881-V-2 series, 880-V-2-4 series, 881-V-2-4 series consisting of light units 88-3V00.

Table of Contents

List of Tables	5
1.0 General Information	6
1.1 Scope	6
1.2 Equipment Description	6
1.2.1 Type	6
1.2.2 Style A, Voltage Powered	6
1.2.3 Class	6
1.2.4 Lamps	6
2.0 Theory of Operation	7
2.1 FAA PAPI Description	7
2.2 Light Unit	8
2.3 Aiming Angle	9
2.4 Digital Aiming Tilt Sensor	10
3.0 FAA Siting Considerations	11
4.0 Installation	26
4.1 Placement of the Light Units	26
4.2 Placement of the Power and Control Unit	28
4.3 Electrical Requirements	29
4.4 Determining the Correct Wire Size	29
4.5 Foundation Requirements	30
4.6 Assembly of the Light Unit	31
4.7 Wiring the Light Unit	33
4.8 Power and Control Unit Electrical Hookup	36
5.0 Aiming	41
5.1 Digital Aiming Tilt Sensor	41
5.2 Aiming Angle	42
5.3 Aiming the Light House Unit	43
6.0 Power Control Unit	47
6.1 Power Control Module LED Indicators	47
6.2 How the Power Control Unit Electronic Functions Work	49
6.3 Adjusting the High Intensity Output Voltage of the PCU	51
6.4 Calibrating the PCU Printed Circuit Board	52
6.5 Adjusting the Low Intensity Output Voltage of the PCU	52
6.6 Installing a Runway Lights Interlock	52
6.7 Installing the Photocell Light Detector	53

7.0 Operating Instructions	54
7.1 Basic Maintenance	54
7.2 Replacing a Lamp.....	54
7.3 Local Control Override	55
7.4 Troubleshooting System Out of Tilt.....	55
Appendix	64

List of Figures

Figure 1: Signal Presentation	8
Figure 2: Aiming Angle	9
Figure 3: Digital Aiming Tilt Sensor, DATS	10
Figure 4: Distance to Threshold	26
Figure 5: Field Placement.....	27
Figure 6: Placement of Light Unit.....	28
Figure 7: Power Control Unit Placement	29
Figure 8: Floor Flange Placement	31
Figure 9: EMT Cut Dimension.....	32
Figure 10: Light Unit Breakaway Plug Connection	33
Figure 11: Light Unit Wiring	35
Figure 12: Power Control Unit Electrical Hook-up	37
Figure 13: Power Control Unit Wiring Diagram.....	38
Figure 14: L880 Style A, Wiring Diagram.....	39
Figure 15: L881 Style A, Wiring Diagram.....	40
Figure 16: Digital Aiming Tilt Sensor, DATS	41
Figure 17: Aiming Angle	42
Figure 18: Front View, Leveling.....	43
Figure 19: Powering the Digital Aiming Tilt Sensor	44
Figure 20: Side View, Aiming Adjustment.....	45
Figure 21: Digital Aiming Tilt Sensor	46
Figure 22: Voltage PAPI LED Information	47
Figure 23: Photocell Printed Circuit Board Connection	50
Figure 24: Photocell Mounting.....	53
Figure 25: Photocell PCB Connector	53
Figure 26: Digital Aiming Tilt Sensor LED Indicators.....	56
Figure 27: Power Control Unit Parts.....	59
Figure 28: Parts VPAPI Light Unit	60

Figure 29: Parts External Fittings.....	61
Figure 30: Parts, Wire Harnesses	62
Figure 31: Mounting Hardware	63
Figure 32: 4 Leg Floor Flange Placements	64

List of Tables

Table 1: Wire Selection	30
Table 2: Trouble Shooting Chart	56
Table 3: Replacement Parts	57

The Tables and Figures in Section 3 have the same numbers as the original FAA Advisory Circular.

Table 7-1: Threshold Crossing Height	
Table 7-2: Aiming of Type L-880 (4 Box) PAPI Relative to Pre-selected Glide Path.	
Table 7-1: Aiming of Type L-881 (2 Box) PAPI Relative to Pre-selected Glide Path.	

Figure 79: PAPI Obstacle Clearance Surface.	
Figure 80: PAPI Signal Presentation.	
Figure 81: Correction for Runway Longitudinal Gradient.	
Figure 90: PAPI Light Housing Unit (LHU) Installation Detail.	
Figure 133: Standard Details for Precision Approach Path Indicators (PAPIs) – PAPI Light Unit Locations.	
Figure 134: Standard Details for Precision Approach Path Indicators (PAPIs).	
Figure 135: Standard Details for Precision Approach Path Indicators (PAPIs) – Section A-A.	

Note:

All shaded text items are direct excerpts from FAA Advisory Circulars

1.0 General Information

1.1 Scope

This instruction manual is provided for use with FAA type L-880 and L-881, Style A, Precision Path Approach Indicator (PAPI) as covered by FAA AC-150/5345-28G and manufactured by Airport Lighting Co., Manlius, NY, USA. It is for use with PAPI systems, 880-V-2 series, 881-V-2 series, 880-4-V-2 series and 881-4-V-2 series, consisting of light units 88-3V00, and the power control unit 88-4V00.

1.2 Equipment Description

1.2.1 Type

- a. L-880 system consists of 4 light units
- b. L-881 system consists of 2 light units

1.2.2 Style A, Voltage Powered

Style A PAPI system is supplied 240VAC single phase power. The power is brought into a power control unit (PCU). The PCU contains some electronic circuitry which controls and detects a number of functions. The functions controlled by the PCU include intensity control. The functions detected by the PCU include: ambient light level, lamp over-voltage, remote control sensing, lamp failure, and optional runway interlock. The electricity coming into the power control unit is transformed to correct output voltage to operate the light units. The output voltage is adjusted by the PCU to deliver the correct light intensity.

1.2.3 Class

All PAPI systems of the above referenced catalog number 880-V-2 series, 881-V-2 series, 880-4-V-2 series, and 881-4-V-2 series, consisting of light units 88-3V00 and power control unit 88-4V00 series are Class II, and operate at a lower limit of minus 67 degrees F (-55 degrees C) and upper limit of 131 degrees F (55 degrees C). By virtue of this fact, they are automatically qualified to Class I which operate at a lower limit of minus 31 degree F (-35 degrees C) and an upper limit of 131 degrees F (55 degrees C).

1.2.4 Lamps

All PAPI light units contain 3 type MR16 lamps with integral reflectors, 105 watts each, at 6.6 amps. The replacement lamp part number is 106.

2.0 Theory of Operation

The Precision Approach Pathway Indicator (PAPI) system is a system made up of either two or four lights. The lights are placed at the side of the runway at the touchdown location. The lights have a split beam which is viewed as red when viewed from below the center of the beam and white when viewed above the center of the beam. This provides the pilot with a light signal letting him know if he is above or below the correct glidepath.

2.1 FAA PAPI Description

Note: Please check www.faa.gov for the latest update of any advisory circulars that are referenced in this manual.

The FAA describes the PAPI system as;

(AC150/5340-30C, 7.3.f (4))

PAPI

This system provides visual approach slope guidance. On runways not provided with electronic guidance, the light signals are beneficial in aiding the pilot of an aircraft to determine the correct glide slope. The presence of objects in the approach area may present a serious hazard if an aircraft descends below the normal path. This is especially true where sources of visual reference information are lacking or deceptive: i.e., hilltops, valleys, terrain grades, and remote airports. The PAPI assists the pilot in maintaining a safe distance above hazardous objects. The visual aiming point obtained with the PAPI reduces the probability of undershoots or overshoots. The 2-box PAPI system is normally installed on runways that are not provided with electronic guidance, on non-Part 139 airports, or when there is a serious hazard where the aircraft descends below the normal approach path angle. The system can be expanded to a 4-box system when jet aircraft operations are introduced at a future time.

(AC150/5340-30C, 7.4.d)

Configurations

PAPI

Provide light units that project the visual signal towards an approaching aircraft with the innermost light unit located 50 feet (15 m) from the left runway edge. The light units are installed in a line perpendicular to the runway edge. Each light unit emits a two-color (red and white) light beam. When the light units are properly aimed, the optical system provides visual approach slope information. Where terrain, intersecting runways, or taxiways make an installation on the left side of the runway impractical, the light housing units may be located on the right side of the runway. See 7.5c (5) for aiming criteria. See 0 for PAPI signal presentation as seen from the approaching aircraft.

L-880

L-881

	<p>TOO HIGH 4 - White 0 - Red</p>		<p>TOO HIGH 2 - White 0 - Red</p>
	<p>SLIGHTLY HIGH 3 - White 1 - Red</p>		
	<p>ON GLIDEPATH 2 - White 2 - Red</p>		<p>ON GLIDEPATH 1 - White 1 - Red</p>
	<p>SLIGHTLY LOW 1 - White 3 - Red</p>		
	<p>TOO LOW 0 - White 4 - Red</p>		<p>TOO LOW 0 - White 2 - Red</p>

Figure 1: Signal Presentation

2.2 Light Unit

The PAPI system is comprised of either 2 or 4 Light Units. Each Light Unit projects a split beam of light with white on the top and red on the bottom. The transition between the colors in the split beam is sharp, due to the properties of the lens and filter combination. The line that designates the change from red to white is parallel to the bottom plate of the Light Unit. The Light Unit is aimed by tilting the Light Unit upward. Each Light Unit consists of three lamps in order to help insure against a light unit out situation and to meet FAA photometric requirements. If one of the lamps in a light unit goes out, the other two lamps will continue to function. From a distance each light unit appears as a single light source. The two or four light pattern is created by using two or four light units.

2.3 Aiming Angle

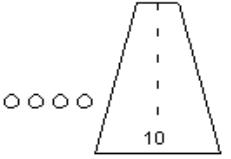
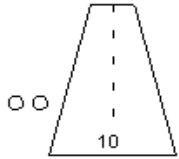
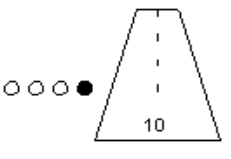
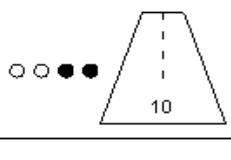
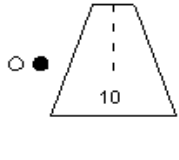
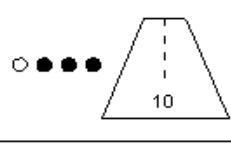
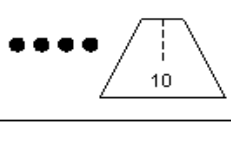
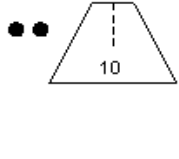
The Aiming Angle is the angle above horizontal bar at which the light unit is aimed. The unit closest to the runway will have the largest Aiming Angle, the Aiming Angles will then recede in value with the unit farthest from the runway having the smallest value.

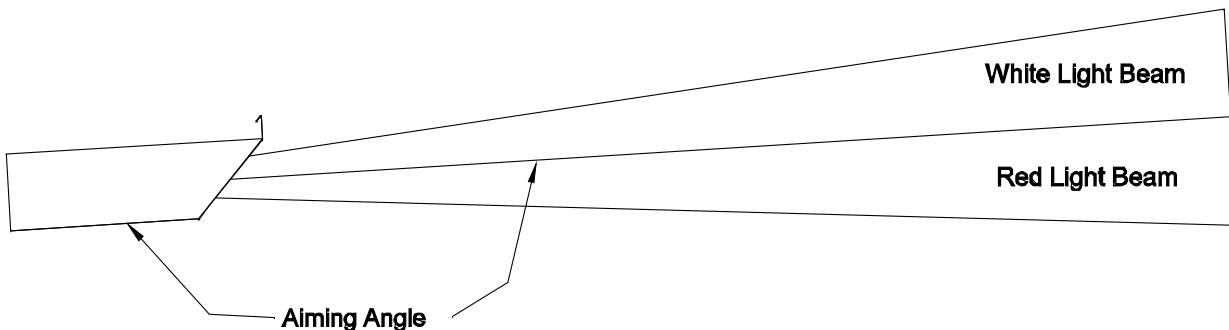

Figure 2: Aiming Angle

In order to guide the pilot in to a safe landing, the Aiming Angles of the Light Units are set to values above and below the runway glide slope.

2.4 Digital Aiming Tilt Sensor

A Digital Aiming Tilt Sensor, DATS, is present in each light unit, and is designed to display the aiming angle and provide a signal to trigger the shutdown of the PAPI system should any of the light units be displaced from its aimed position. It is set after the light unit has been aimed. The tilt switch is designed to allow operation when the light unit is properly aligned. The DATS relay switch will open when the light unit is tilted down. The switching will occur when the light unit is tilted between $\frac{1}{4}$ and $\frac{1}{2}$ a degree down and the switch will remain open in all tilt switch positions beyond this range. The DATS relay switch will open when the light unit is tilted up. The switching will occur when the light unit is tilted between $\frac{1}{2}$ and 1 degree up and the switch will remain open in all tilt switch positions beyond this range. Shutdown will occur after a 10 second but before a 30 second period of continuous tilt out signal in accordance with FAA requirements.

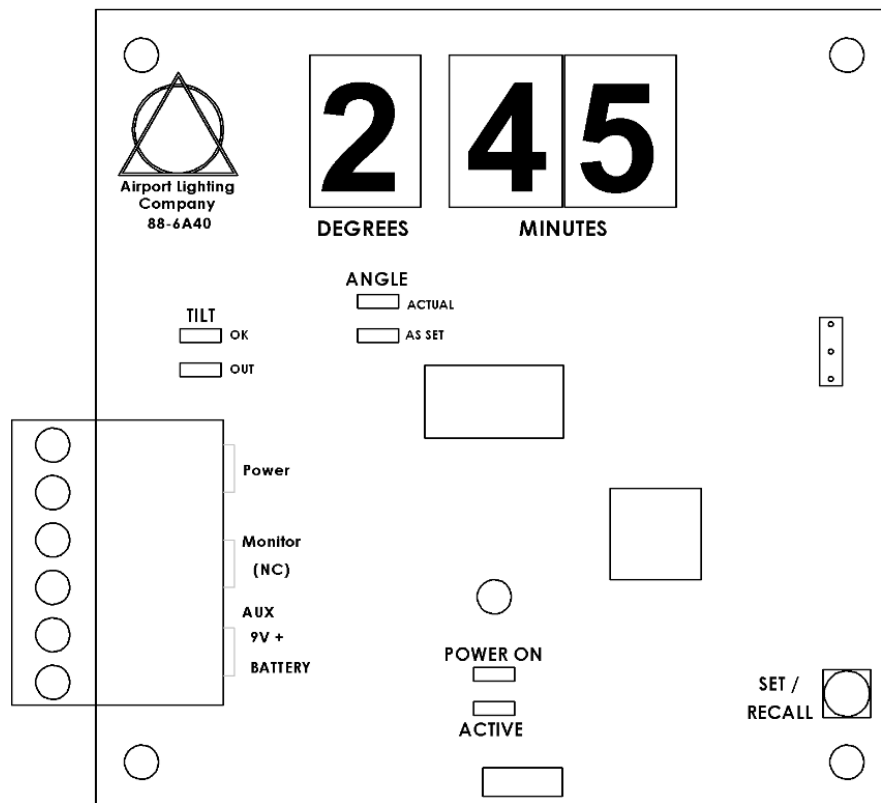

Figure 3: Digital Aiming Tilt Sensor, DATS

3.0 FAA Siting Considerations

The FAA provides the following siting considerations;

Note: Please check www.faa.gov for the latest update of any advisory circulars that are referenced in this manual.

(AC150/5340-30C, 7.5.d)

7.5. Design.

d. PAPI

(1) Siting Considerations

- (a) The PAPI system should be located at the approach end of the runway on the left side.
- (b) The PAPI must be sited and aimed so it defines an approach path with sufficient clearance over obstacles and a minimum threshold crossing heights per Table 7.1.
- (c) See the manufacturer's installation manual for a light housing assembly aiming procedure.
- (d) Other PAPI alignment tolerances and considerations common to installations are in paragraph 7.5h.

(2) Siting PAPI on a Runway With an ILS Glide Path. When siting PAPI on a runway with an ILS system, the PAPI visual approach path must coincide with the ILS glide path. The PAPI must be placed at the same distance from the threshold as the touchdown point of the ILS glide path with a tolerance of ± 30 feet (± 10 m). If the PAPI is installed on an ILS runway primarily used by aircraft in height group 4 (see Table 7.1), the PAPI distance from the threshold must equal the distance to the ILS glide path touchdown point plus an additional 300 feet $+50$, -0 (90 m $+15$, -0) from the runway threshold.

(3) Siting PAPI on a Runway Without an ILS Glide Path. When a runway is not ILS equipped, the position and aiming for the PAPI must be aligned to produce the required threshold crossing height and obstacle clearance for the runway approach path per the following:

NOTE: The following method can be used to determine the PAPI distance from the runway threshold provided there are no obstacles in the area from which the PAPI signals can be observed, no differences in elevation between the threshold and the installation zone of the PAPI or between the units, or reduced length of runway.

(a) The distance of the PAPI units from the runway threshold can be calculated from the equation:

$$D1 = TCH \times \cot(\text{angle of lowest on-course signal})$$

D1 = calculated distance of the PAPI unit from the runway threshold
TCH = threshold crossing height

(b) The TCH is determined by the height group of aircraft that primarily use the runway. Refer to Table 7-1 and determine the recommended TCH.

(c) Refer to Table 7-2 and determine the lowest on course signal for the third light unit from the runway edge - 10 minutes (') below glidepath.

(d) The standard visual glideslope for PAPI is 3°. For non-jet runways, the glideslope may be increased to 4° to provide obstacle clearance.

(e) The aiming angle of the third light unit is:

$$3^\circ - 10' = 2^\circ 50'$$

(f) Determine the distance of the PAPI from the runway threshold (TCH = 45 feet, Height Group 2):

$$D1 = 45 \times \text{cotangent } 2^\circ 50' \quad (2^\circ 50' = 2.833^\circ) \quad (\text{cotangent} = 1/\tan)$$

$$D1 = 45 \times 20.20579$$

$$D1 = 909.26 \text{ feet from the runway threshold}$$

e. PAPI Obstacle Clearance Surface (OCS).

(a) Reference 0. The PAPI obstacle clearance surface is established to provide the pilot with a minimum clearance over obstacles during approach. The PAPI must be positioned and aimed so that no obstacles penetrate this surface. The surface begins 300 feet (90 m) in front of (closer to the runway threshold) the PAPI system and proceeds outward into the approach zone at an angle 1 degree less than the aiming angle of the third LHA (lowest on course signal, L-880) from the runway. For an L-881 PAPI, the lowest on course signal is for the unit farthest from the runway. The OCS extends 10° on either side of the runway centerline to a distance of 4 miles (6.44 km) from the point of origin.

(b) Position and aim the PAPI so that there is no risk of an obstruction penetrating the OCS. Perform a site survey and verify that an obstruction will not penetrate the OCS.

(c) If an obstruction penetrates the obstacle clearance surface and cannot be removed, increase the PAPI glideslope angle or move the PAPI farther from the threshold to provide an increased TCH equal to the obstacle penetration height. Use the following formula:

$$D1 = TCH + H \times \text{cotangent } \theta$$

where:

D1 = calculated distance of the PAPI from the runway threshold

TCH = threshold crossing height

H = the height of the object above the OCS

θ = PAPI lowest on course signal

(5) Threshold Crossing Height (TCH). The TCH is the height of the lowest on-course signal at a point directly above the intersection of the runway centerline and the threshold.

(a) The minimum TCH varies with the height group of aircraft that primarily use the runway.

(b) The PAPI approach path must provide the proper TCH for the most demanding height

group using the runway per Table 7.1.

- (6) **PAPI AIMING.** The standard aiming angles for Type L-880 and Type L-881 systems are shown in Tables 7.2 and 7.3.

Table 7-2. Threshold Crossing Heights.

Representative aircraft type	Approximate Cockpit-to-wheel height	Visual Threshold Crossing Height	Remarks
<u>Height Group 1</u> General aviation Small commuters Corporate turbo jets	10 feet (3 m) or less	40 feet (+5, -20) 12 m (+2, -6)	Many runways less than 6,000 feet (1829 m) long with reduced widths and/or restricted weight bearing that would normally prohibit landings by larger aircraft.
<u>Height Group 2</u> F-28, CV-340/440/580 A-737, DC-9, DC-8	15 feet (4.5 m)	45 feet (+5, -20) 14 m (+2, -6)	Regional airport with limited air carrier service
<u>Height Group 3</u> B-727/707/720/757	20 feet (6 m)	50 feet (+5,-15) 15 m (+2, -6)	Primary runways not normally used by aircraft with ILS glide-path-to-wheel heights exceeding 20 feet (6 m).
<u>Height group 4</u> B-747/767, L-1011, DC-10 A-300	Over 25 feet (7.6 m)	75 feet (+5, -15) 23 m (+2, -4)	Most primary runways at major airports.

Table 7-3. Aiming of Type L-880 (4 Box) PAPI Relative to Pre-selected Glide Path.

Light Unit	Aiming Angle (in minutes of arc)	Ht group 4 aircraft. on runway with ILS
	Standard installation	
Unit nearest runway	30' above glide path	35' above glide path
Next adjacent unit	10' above glide path	15' above glide path
Next adjacent unit	10' below glide path	15' below glide path
Next adjacent Unit	30' below glide path	35' below glide path

Table 7-4. Aiming of Type L-881 (2 Box) PAPI Relative to Pre-selected Glide Path.

Light Unit	Aiming angle (in minutes of arc)
Unit nearest runway	15' above glide path
Unit farthest from runway	15' below glide path

(7) OTHER SITING DIMENSIONS AND TOLERANCES.

(a) Distance from Runway Edge:

1. The inboard light unit must be not be less than 50 feet, +10, -0, (15 m, +3, -0) from the runway edge (see 0) or to other runways or taxiways.
2. The distance from the runway edge may be reduced to 30 feet (10 m) for small general aviation runways used by non-jet aircraft.

(b) Separation Between Light Units:

1. The PAPI light units must have a lateral separation of:

- a. Between 20 and 30 feet (6 to 9 m) for L-880 systems.

NOTE: the distance between light units is measured center to center.

- b. For the L-880, the distance between light units may not vary by more than ± 1 foot (0.3 m).

(c) Azimuth Aiming. Each light unit must be aimed outward into the approach zone on a line parallel to the runway centerline within a tolerance of $\pm 1/2$ degree.

(d) Mounting Height Tolerances.

1. The beam centers of all light units must be within ± 1 inch of a horizontal plane.
2. The PAPI horizontal plane must be within 1 foot (0.3 m) of the elevation of the runway centerline at the intercept point of the visual glide path with the runway (except for the siting conditions in subparagraph g below).

(e) Tolerance Along Line Perpendicular to Runway. The front face of each light unit in a bar must be located on a line perpendicular to the runway centerline within +6 inches (+152 mm).

(f) Correction for Runway Longitudinal Gradient.

1. On runways where there is a difference in elevation between the runway threshold and the PAPI, it may be necessary to adjust the location of the light units with respect to the threshold to meet the required obstacle clearance and TCH.
2. When an elevation difference exists, the following steps (reference 0) must be used to compute the change in the distance from the threshold required and preserve the proper geometry.
 - a. Obtain the runway longitudinal gradient (RWY) from “as-built” drawings or airport obstruction charts.

NOTE: *If the information cannot be obtained from the above sources, a survey must be performed to obtain RWY.*

- b. Determine the ideal (D1, zero gradient) PAPI distance from the runway threshold (T).
- c. Assume a level reference plane at the runway threshold elevation. Plot the location determined in (2) above.
- d. Plot the runway longitudinal gradient (RWY).
- e. Project the visual glide path angle (θ) to its intersection with the runway longitudinal gradient (RWY).
- f. Solve for the adjusted distance from threshold (d) either mathematically or graphically.
- g. Double-check to see that the calculated location gives the desired TCH.

(g) Additional Siting Considerations.

1. If the terrain drops off rapidly near the approach threshold and severe turbulence is experienced, then PAPI must be located farther from the threshold to keep the aircraft at the maximum possible threshold crossing height.
2. For short runways, the PAPI must be as near the threshold as possible to provide the maximum amount of runway for braking after landing.

3. At locations where snow is likely to obscure the light beams, the light units may be installed so the top of the unit is a maximum of 6 feet (2 m) above ground level.
4. PAPI LHAs must not be located closer than 50 feet from a crossing runway, taxiway, or warm-up apron or within the ILS critical area.
5. The inboard light housing may be located up to 75 feet (23 m) from the runway edge where damage may occur arising from jet blast and wing vortices. This is a deviation from standard and must be submitted to the local Airport District Office for approval prior to installation.

NOTES:

- *Increasing the height of the PAPI light units will also raise the threshold crossing height for the glide path.*
- *This may also require locating the light units farther from the runway edge to ensure adequate clearance for aircraft.*
- *The location for the light units (closer to the runway threshold) must be recalculated to maintain the correct TCH and Obstacle Clear Surface (OCS).*

Electrical Systems. Select equipment and connect the light units for continuous operation. See Figure 89 for typical wiring diagram.

- (a) Continuous Operation. Provide a continuous power source to permit the PAPI to be energized at all times.
- (b) Series Operation. (not applicable to Style A)
- (c) Multiple Operation. Use the light boxes with accessories provided for the specification to permit operation from a 2 Kw, 120-volt \pm 10 percent, 60 Hz source or a 240 volt \pm 10 percent, 60 Hz source. Control the on/off operation of the light units with a remote switch or with radio controls. Provide pilot relays with contacts rated to operate the 2-kilowatt load on a continuous basis.
- (d) Wire. (not applicable to Style A)

Foundation. See 90 for design details for the light unit's foundation.

- (8) Feeder Circuit. The PAPI may be specified to operate from a standard utility voltage (Style A)
 - (a) The power cable must be per FAA Type L-824 per AC 150/5345-7, *Specification for L-624 Underground Electrical Cable for Airport Lighting Circuit*, or equivalent.
 - (b) Lightning arresters for both power and control lines must be provided per AC/150-5345-28, *Precision Approach Path Indicator (PAPI) Systems*.

NOTE: *The output power lines for an L-828 regulator used for Style B systems already have integral lightning protection).*

(c) All fuses or circuit breakers must be within the equipment ratings.

(11) Style A PAPI Systems.

(a) Input Voltage. Although PAPI systems may be designed to operate from any standard utility voltage:

1. The site designer must ensure the PAPI will operate from the airfield service voltage available and avoid installing a transformer for the system operating voltage.
2. The site designer must determine if there is any fluctuation in the utility line voltage exceeding the PAPI power design limits that will cause reduced lamp life.
 - a. If the line voltage variations exceed the PAPI power regulation limits, then a voltage regulator must be provided to ensure the PAPI provides its specified lamp brightness.
3. The power distribution cabling to individual light units must be sized so any voltage drop does not exceed the PAPI power design limits.

(b) Location of the Power and Control Unit (PCU).

1. The PCU must be located as far from the runway as possible for a minimum obstruction to aircraft.
2. If the PCU is integral with a light unit, it must be placed farthest from the runway.
3. If the PCU is a separate unit, it must be mounted at the minimum possible height, and located outside the RSA.
4. If the PCU cannot be located outside the RSA, it must be mounted with frangible couplings and breakaway cabling.

(12) Style B PAPI System. (not applicable to Style A)

(13) Wiring the PAPI Light Units.

- (a) For Style A systems, the cable used to deliver the power to the individual light units must be a gauge large enough to minimize any voltage drop.
- (b) Ensure all PAPI light boxes are properly grounded to the connection point provided by the manufacturer.
- (c) All wiring entering the PAPI light unit must be through plugs and receptacles that will separate if the box is struck by an aircraft. The receptacles are located and secured at the frangible couplings.
- (d) A length of flexible watertight conduit conveys the PAPI wiring between the frangible coupling and the PAPI light box. The flexible conduit is required so the PAPI box has sufficient movement for proper aiming.
- (e) All underground connections must be made with either splices or plugs and receptacles per AC 150/5345-26, *Specification for L-823, Plug and Receptacle, Cable Connectors.*

(14) PAPI Lamp Brightness Control.

(a) Style A Systems.

1. The Style A PAPI system automatically selects day or night intensity settings with a photocell.
2. There are two night intensity settings (one time manual configuration), approximately 5 and 20 percent of full intensity, when the PAPI is in night mode.
3. Style B Systems. (not applicable to Style A)

(15) PAPI Power Control. The PAPI may be turned on and off by a number of different methods.

- (a) For Style A systems, a contactor is provided in the PCU, allowing the system to be turned on and off via control signals.
- (b) For Style B systems, (not applicable to Style A)
- (c) The remote control that activates either Style A or B systems may be located in the control tower, flight service station, or other attended facility.
- (d) Alternatively, the PAPI power control lines may be activated by an L-854 radio control receiver (AC 150/5345-49, *Specification L-854, Radio Control Equipment*). The L-854 allows the PAPI to be energized by either a pilot on approach, or by an airport ground control station.

(16) Other PAPI Power Control Configurations.

(a) PAPIs On Both Runway Ends.

1. It is desirable to independently control PAPIs for each runway end, energizing only the PAPI that serves the active runway end.
2. Turning off both systems when the runway is inactive will conserve energy.

(b) Interlock Relay.

1. During the night, it is desirable that the PAPI be energized only when the runway lights are on.
2. To provide this feature, an interlock relay must be installed in series with the night intensity contacts on the photocell controller.
3. The normally open contacts of the interlock relay are closed only when it is night or the runway edge lights are on.
4. Daylight PAPI operation must not be affected.

(17) Style B PAPI Lamp Bypass (not applicable to Style A)

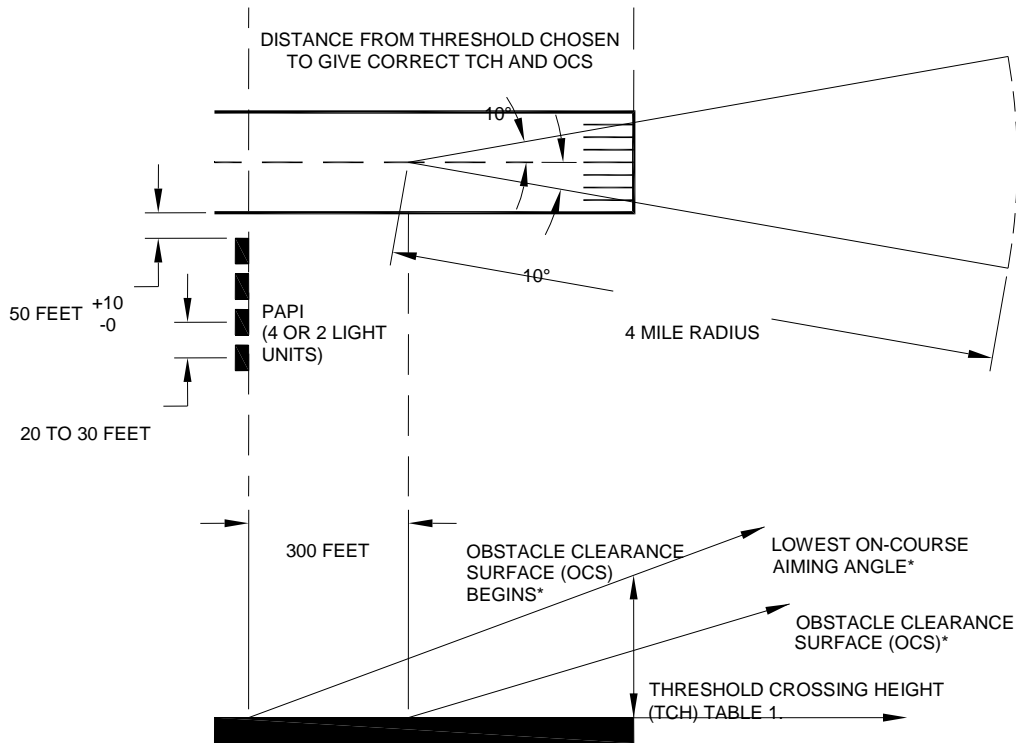

PAPI OCS ANGLE = LOWEST ON-COURSE AIMING ANGLE - 1 DEGREE

NOTES:

1. THE VISUAL GLIDE PATH ANGLE IS THE CENTER OF THE ON-COURSE ZONE, AND IS A NOMINAL 3 DEGREES WHEN MEASURED FROM THE HORIZONTAL SURFACE OF THE RUNWAY.
 - A. FOR NON-JET RUNWAYS, THE GLIDE PATH MAY BE RAISED TO 4 DEGREES MAXIMUM TO PROVIDE OBSTACLE CLEARANCE.
 - B. IF THE PAPI GLIDE PATH IS CHANGED TO A HIGHER ANGLE FROM THE NOMINAL 3 DEGREES, IT MUST BE COMMUNICATED IN A NOTICE TO AIRMAN (NOTAM) AND PUBLISHED IN THE AIRPORT FACILITY DIRECTORY.
2. PAPI OBSTACLE CLEARANCE SURFACE (OCS).
 - A. THE PAPI OCS PROVIDES THE PILOT WITH A MINIMUM APPROACH CLEARANCE.
 - B. THE PAPI MUST BE POSITIONED AND AIMED SO NO OBSTACLES PENETRATE ITS SURFACE.
 - (1) THE OCS BEGINS 300 FEET [90M] IN FRONT OF THE PAPI SYSTEM.
 - (2) THE OCS IS PROJECTED INTO THE APPROACH ZONE DEGREE LESS THEN AIMING ANGLE OF THE THIRD LIGHT UNIT FROM THE RUNWAY FOR AN L-880 SYSTEM, OR THE OUTSIDE LIGHT UNIT FOR AN L-881 SYSTEM.

Figure 79. PAPI Obstacle Clearance Surface.

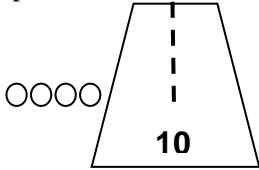
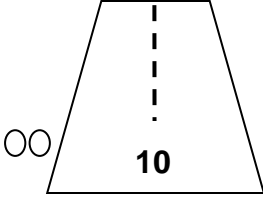
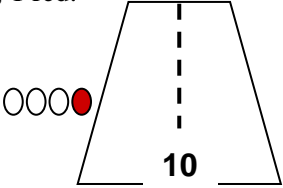
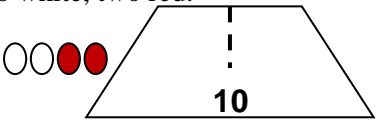
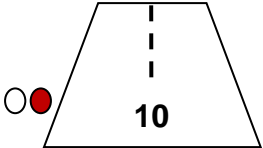
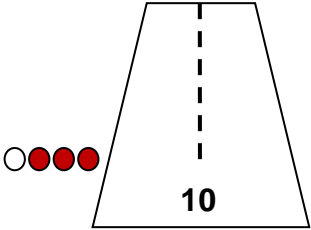
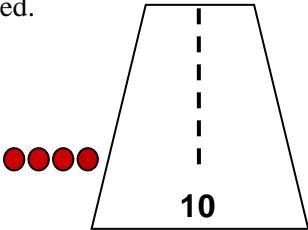
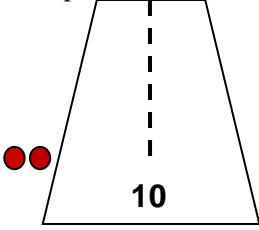
<p>(1) Above correct glide path All lamps white.</p> 	<p>(1) Above the correct glide path: 2 white lamps.</p> 
<p>(2) Slightly above correct glide path. 3 white, 1 red.</p> 	
<p>(3) On the correct glide path. Two white, two red.</p> 	<p>(2) On the correct glide path: 1 white, 1 red.</p> 
<p>(4) Slightly below the correct glide path. 1 white, 3 red.</p> 	
<p>(5) Below the correct glide path: All red.</p> 	<p>(3) Below the correct glide path: Two red lamps.</p> 
<p>Type L-880</p>	<p>Type L-881</p>
<p>NOTE: <i>The PAPI is a system of either four or two identical light units placed on the left of the runway in a line perpendicular to the centerline. The boxes are positioned and aimed to produce the visual signal shown above.</i></p>	
<p>Figure 80. PAPI Signal Presentation.</p>	

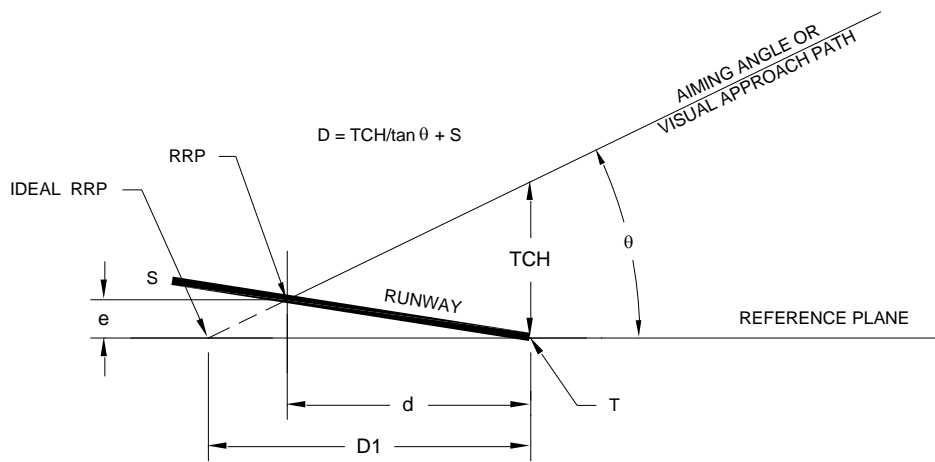

Siting station displaced toward threshold

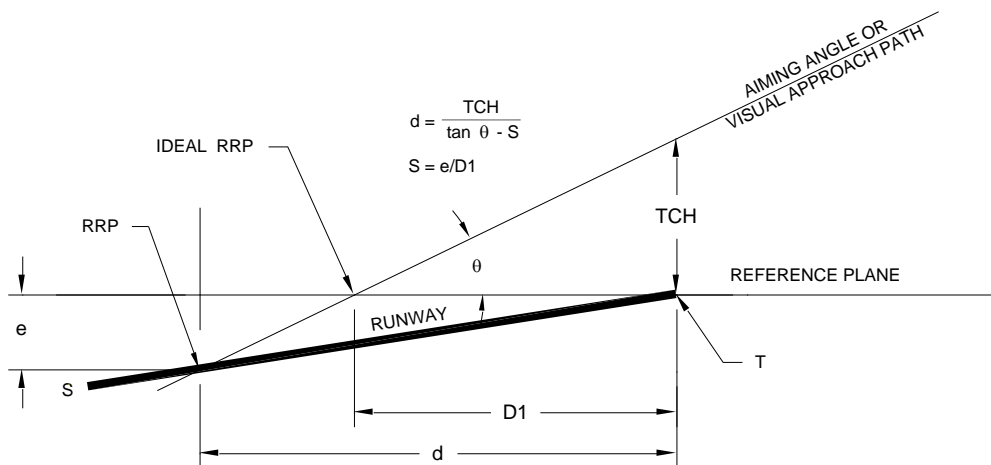

Siting station displaced from threshold

SYMBOLS:

- D1 = ideal (zero gradient) distance from threshold
- RWY = runway longitudinal gradient
- TCH = threshold crossing height
- T = threshold
- e = elevation difference between threshold and RRP
- RRP = runway reference point (where aiming angle or visual approach path intersects runway profile)
- d = adjusted distance from threshold
- θ = aiming angle
- S = percent slope of runway = e/d
(S is used in decimal form in the equations)

Figure 81. Correction for Runway Longitudinal Gradient.

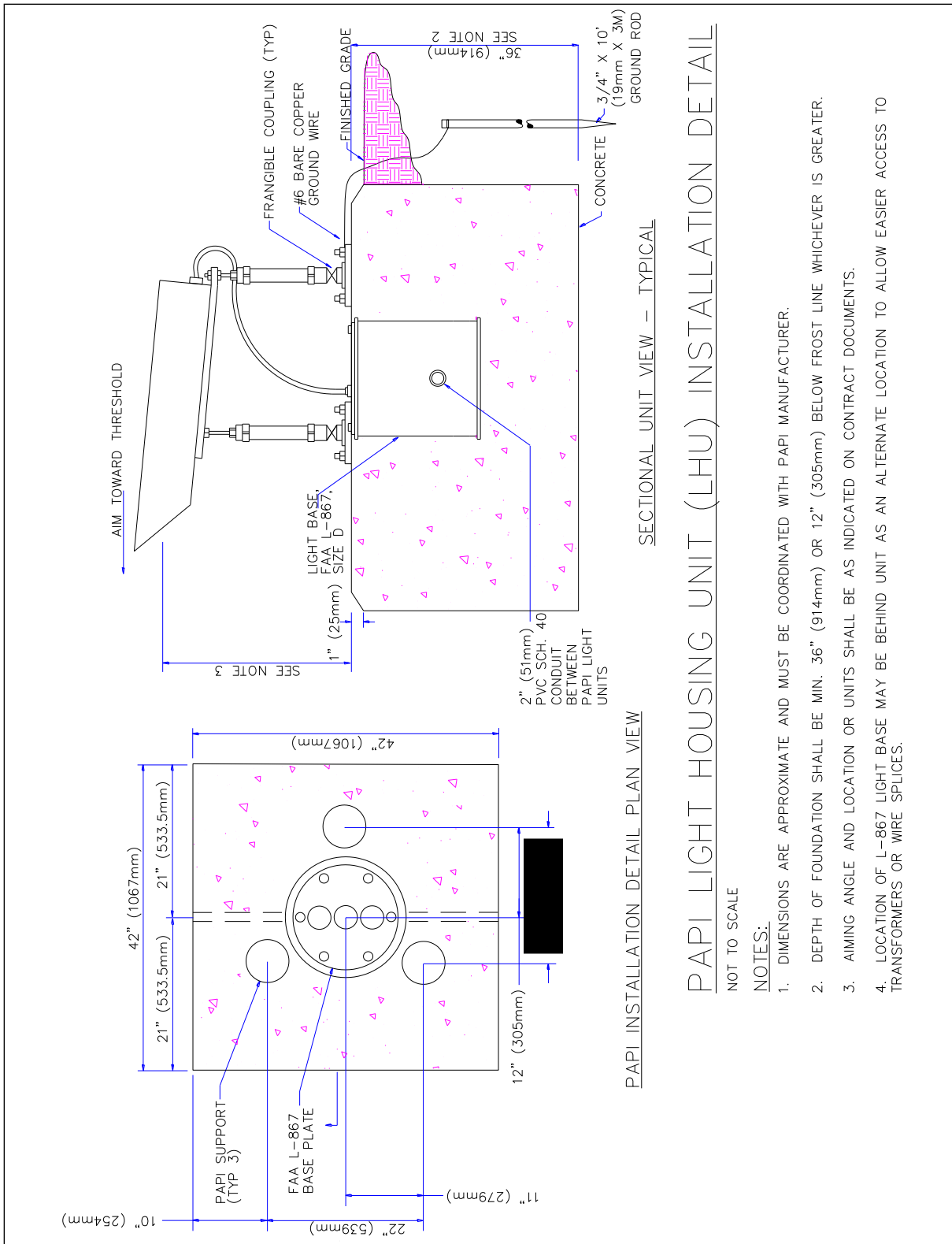

Figure 90. PAPI Light Housing Unit (LHU) Installation Detail.

(Dimensions that don't match Airport Lighting Company's PAPI Light Units have been blacked out; correct dimensions are in assembly drawings)

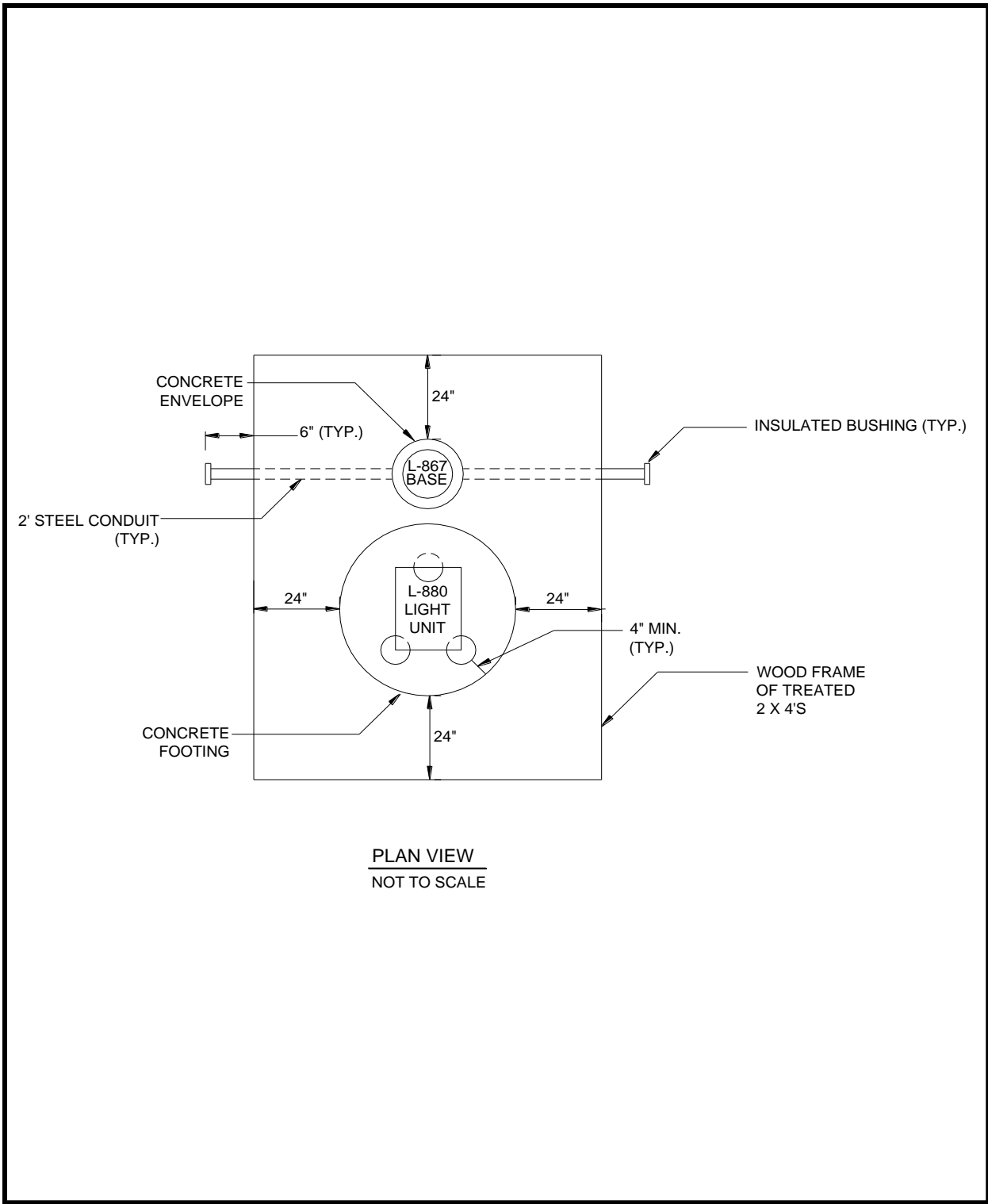

Figure 133. Standard Details for Precision Approach Path Indicators (PAPIs) – PAPI Light Unit Locations.

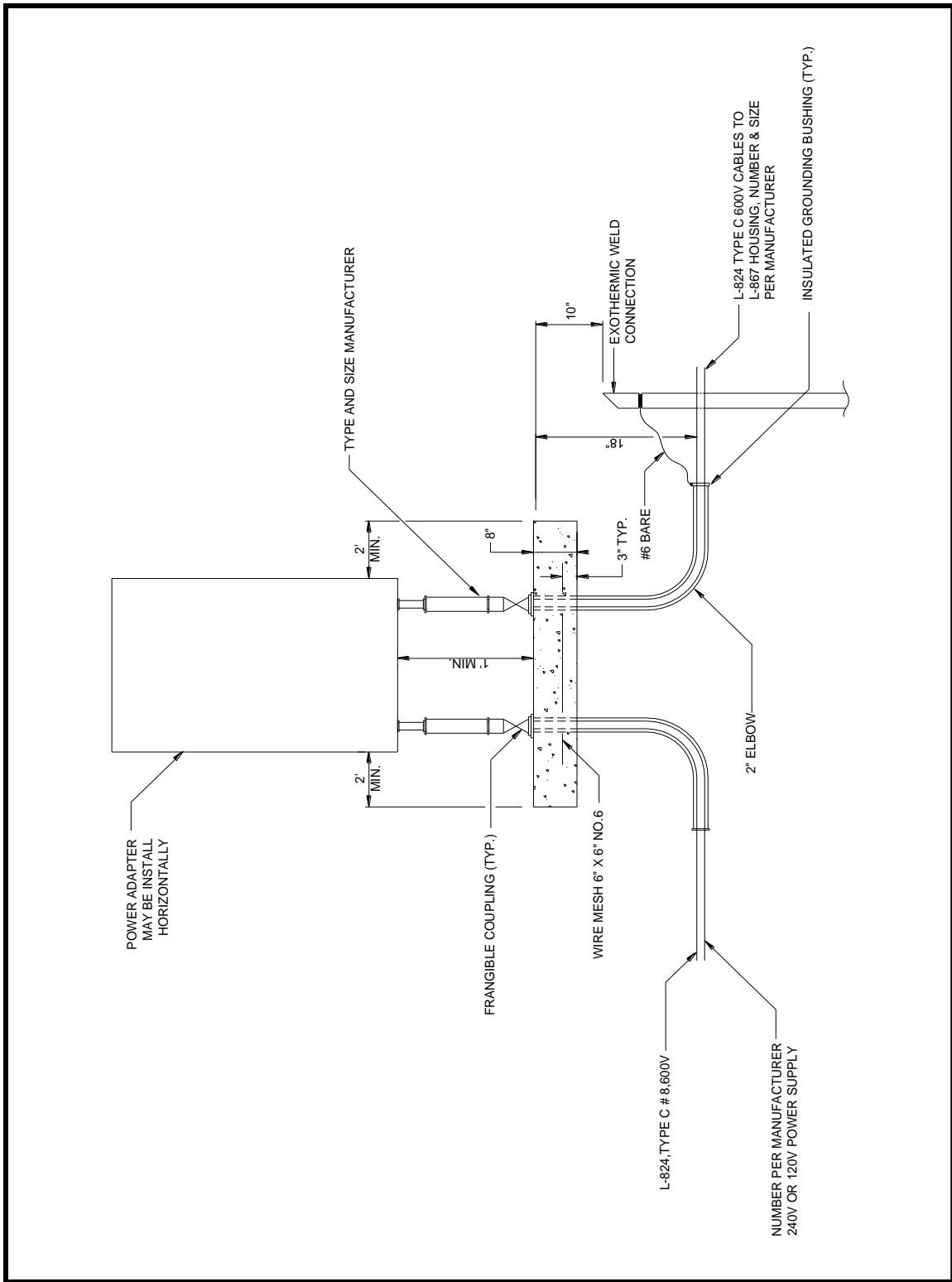

Figure 134. Standard Details for Precision Approach Path Indicators (PAPIs).

4.0 Installation

- Placement of the Light Units
- Placement of the Power Control Unit
- Electrical requirements
- Foundation requirements
- Assembly of the Light Unit
- Wiring the Light Unit
- Power and Control Unit Electrical Hookup

4.1 Placement of the Light Units

The FAA has very specific regulations regarding the placement of the Light Units. The distance from the threshold of the runway to the PAPI light bar is a distance that requires some calculations. The calculations are a function of the Threshold Crossing Height (TCH), the Obstacle Clearance Surface (OCS), the runway longitudinal gradient, the runway glide slope, and what size aircraft will use the runway. If the site plans do not list the distance to threshold, the information to calculate this distance can be found in section 3 of this manual.

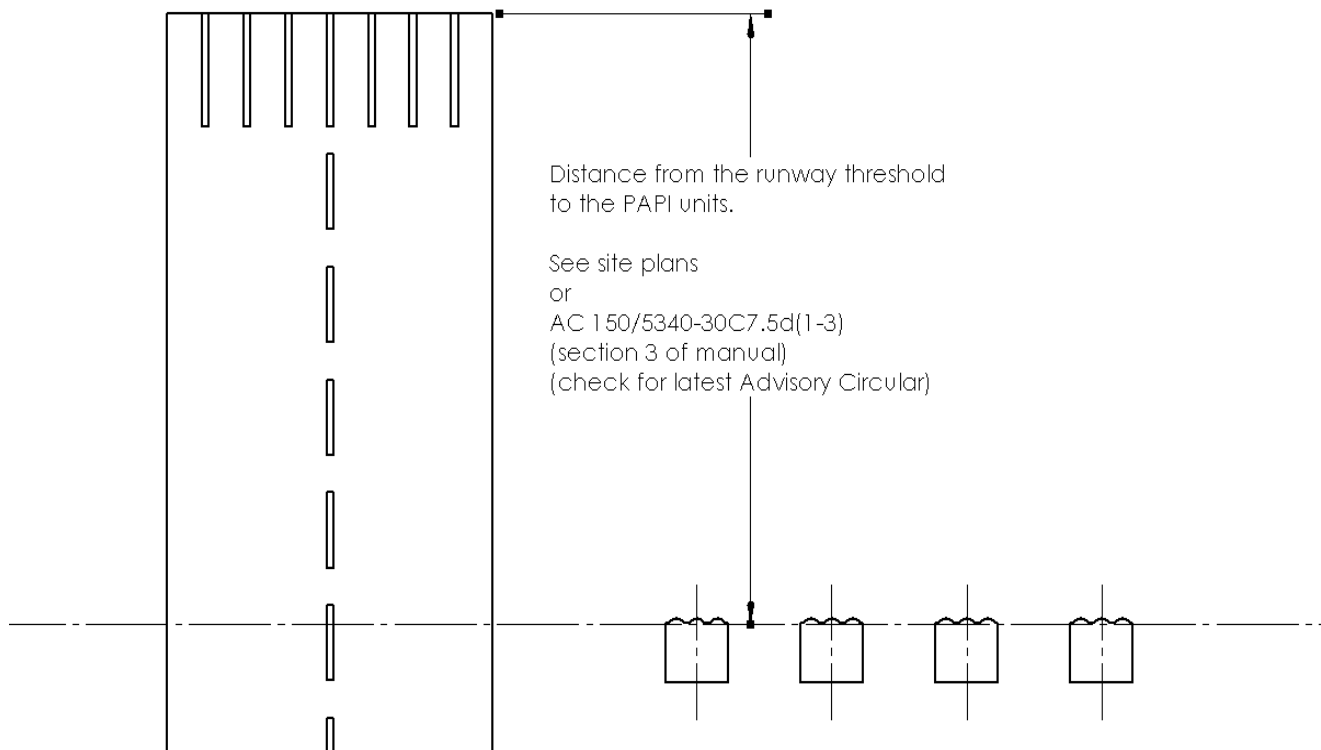

Figure 4: Distance to Threshold

The FAA specifies the placement of the light units as follows;

Distance from Runway Edge:

1. The inboard light unit must be not be less than 50 feet, +10, -0, (15 m, +3, -0) from the runway edge (see 0) or to other runways or taxiways.
2. The distance from the runway edge may be reduced to 30 feet (10 m) for small general aviation runways used by non-jet aircraft.

Separation Between Light Units:

3. The PAPI light units must have a lateral separation of:
 - a. Between 20 and 30 feet (6 to 9 m) for L-880 systems.

NOTE: the distance between light units is measured center to center.

- b. For the L-880, the distance between light units may not vary by more than ± 1 foot (0.3 m).

Azimuth Aiming. Each light unit must be aimed outward into the approach zone on a line parallel to the runway centerline within a tolerance of $\pm 1/2$ degree.

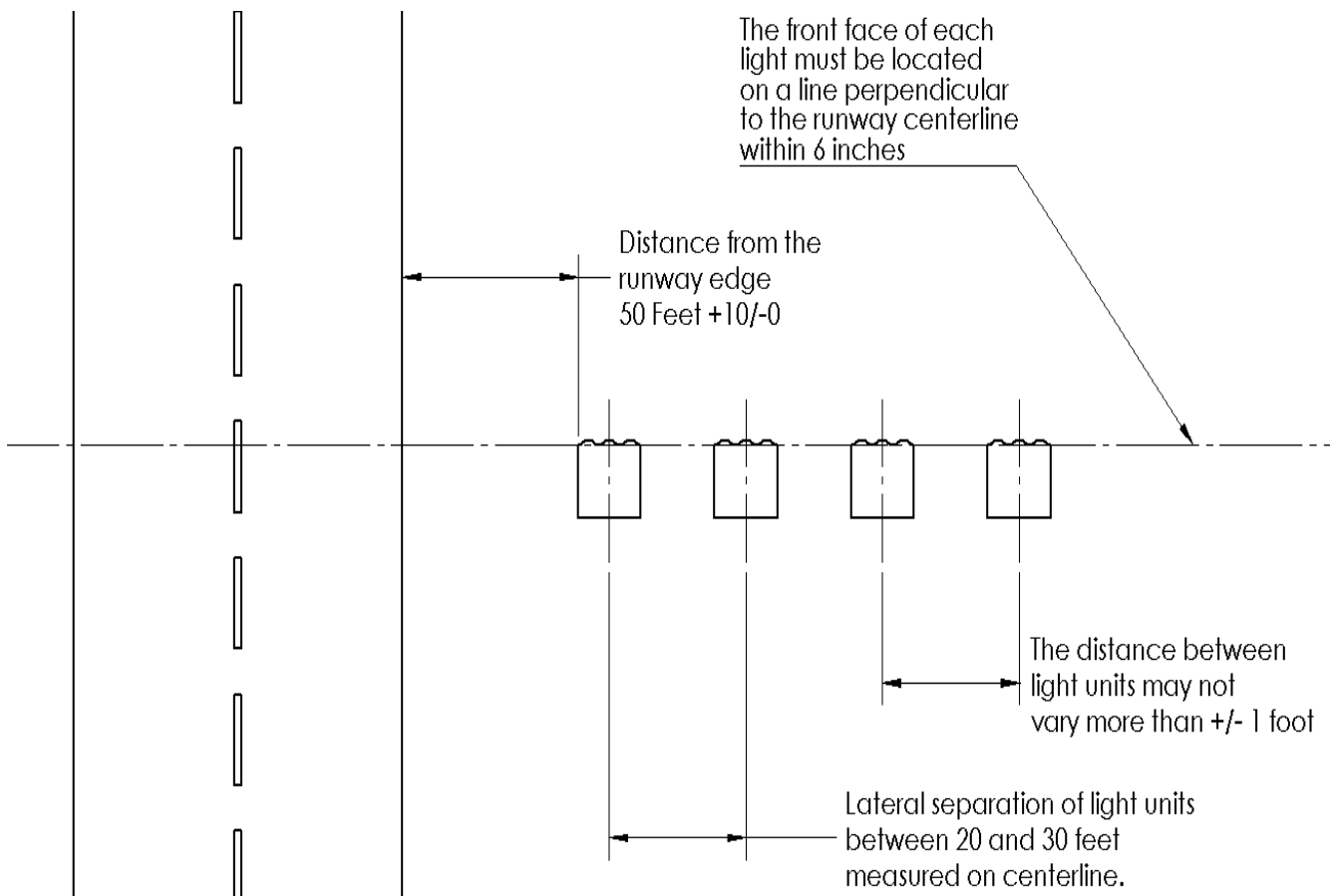

Figure 5: Field Placement

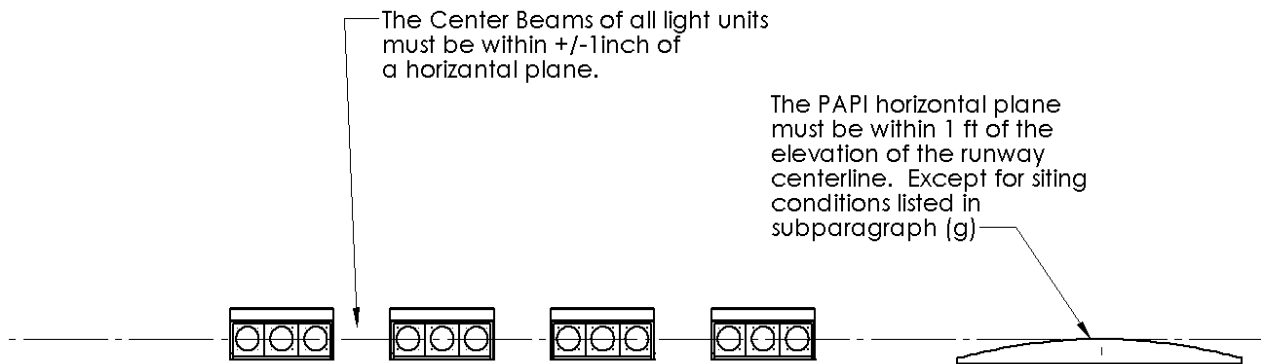

Figure 6: Placement of Light Unit

Mounting Height Tolerances.

4. The beam centers of all light units must be within ± 1 inch of a horizontal plane.
5. The PAPI horizontal plane must be within 1 foot (0.3 m) of the elevation of the runway centerline at the intercept point of the visual glide path with the runway (except for the siting conditions in subparagraph g below).

Tolerance Along Line Perpendicular to Runway. The front face of each light unit in a bar must be located on a line perpendicular to the runway centerline within +6 inches (+152 mm).

4.2 Placement of the Power and Control Unit

The Power and Control Unit is a separate unit that should be positioned as close as possible to the light units and still be within FAA specifications.

FAA specifications for the placement of the power control unit;

Location of the Power and Control Unit (PCU).

The PCU must be located as far from the runway as possible for a minimum obstruction to aircraft.

If the PCU is a separate unit, it must be mounted at the minimum possible height, and located outside the RSA (Runway Safety Area).

If the PCU cannot be located outside the RSA (Runway Safety Area), it must be mounted with frangible couplings and breakaway cabling.

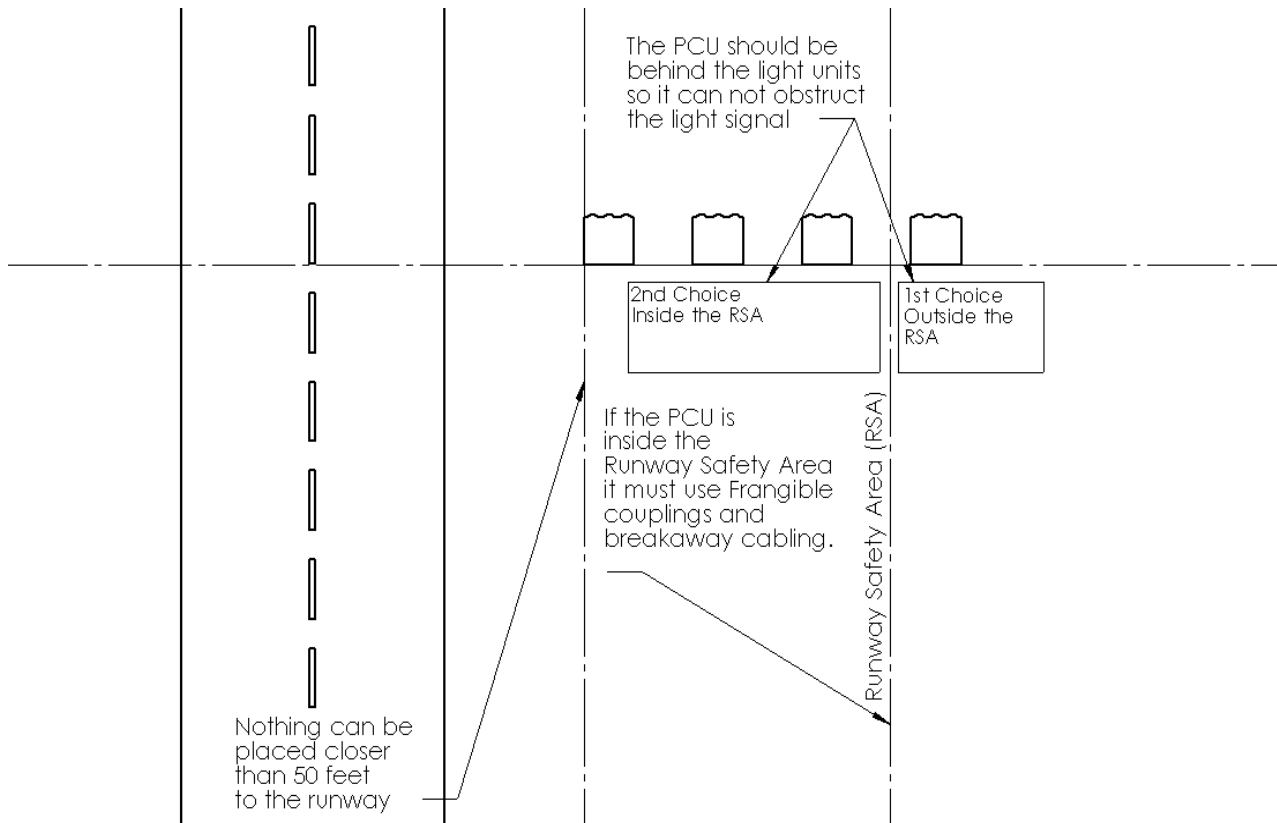

Figure 7: Power Control Unit Placement

4.3 Electrical Requirements

The electrical requirements are:

- Power and control unit (PCU) receives nominal 240 volts at 60 hertz, single phase.
- The PCU delivers the proper voltage to the light units wired in parallel.
- A series loop runs through the Digital Aiming Tilt Sensors at each light unit and back to the PCU
- The light units have a breakaway cable connection at the ground level.
- The PCU must have breakaway cables if it falls inside the runway safety area.
- The PCU has inputs for remote control, and runway interlock detection.

4.4 Determining the Correct Wire Size

Voltage drop is an important consideration when selecting the correct wire size. A drop in voltage will change the light intensity of the lamps at the light unit. Too much voltage will shorten the lamp life and too little voltage will reduce light intensity. The voltage drop is affected by the current carrying capacity of the wire and the length of the wire. A high voltage with low current will have a lower voltage drop than a low voltage with a high current. It is important then to realize that the wiring coming into the power control module is high voltage and low current, and may be long runs. While the wire going from the power control module to the light units is low voltage, high current with shorter runs. A guide to selecting the proper wire size is listed in Table 1.

Table 1: Wire Selection

Circuit	Length (feet)	Wire Size
Power to PCU L880	10 – 100	8 AWG
	100 – 500	6 AWG
	500 – 1000	4 AWG
	1000 – 2000	1 AWG
	2000 +	Use of transformers recommended
Power to PCU L881	10 – 100	10 AWG
	100 – 500	6 AWG
	500 – 1000	4 AWG
	1000 – 2000	2 AWG
	2000 +	Use of transformers recommended
PCU to Light Units L880	10 – 50	6 AWG
	50 – 100	(2) 6 AWG
	50 – 100	4 AWG
	100 - 200	(2) 4 AWG
PCU to Light Units L881	10 – 50	8 AWG
	50 – 100	6 AWG
	100 - 200	4 AWG
Tilt Loop	10 - 200	14 AWG

4.5 Foundation Requirements

The FAA requirements for the PAPI Light Housing Unit and Power and Control Unit can be found in:

Figure 90. PAPI Light Housing Unit (LHU) Installation Details

Figure 133. Standard Details for the Precision Approach Path Indicators (PAPIs)
PAPI Light Unit Locations

Figure 134. Standard Details for the Precision Approach Path Indicators (PAPIs)

Figure 135. Standard Details for the Precision Approach Path Indicators (PAPIs)
Section A-A

Figure 9 shows the placement of the floor flanges used in the leg assembly specific to the Airport Lighting Company light unit.

4.6 Assembly of the Light Unit

Mount three floor flanges to the foundation. The proper location is:

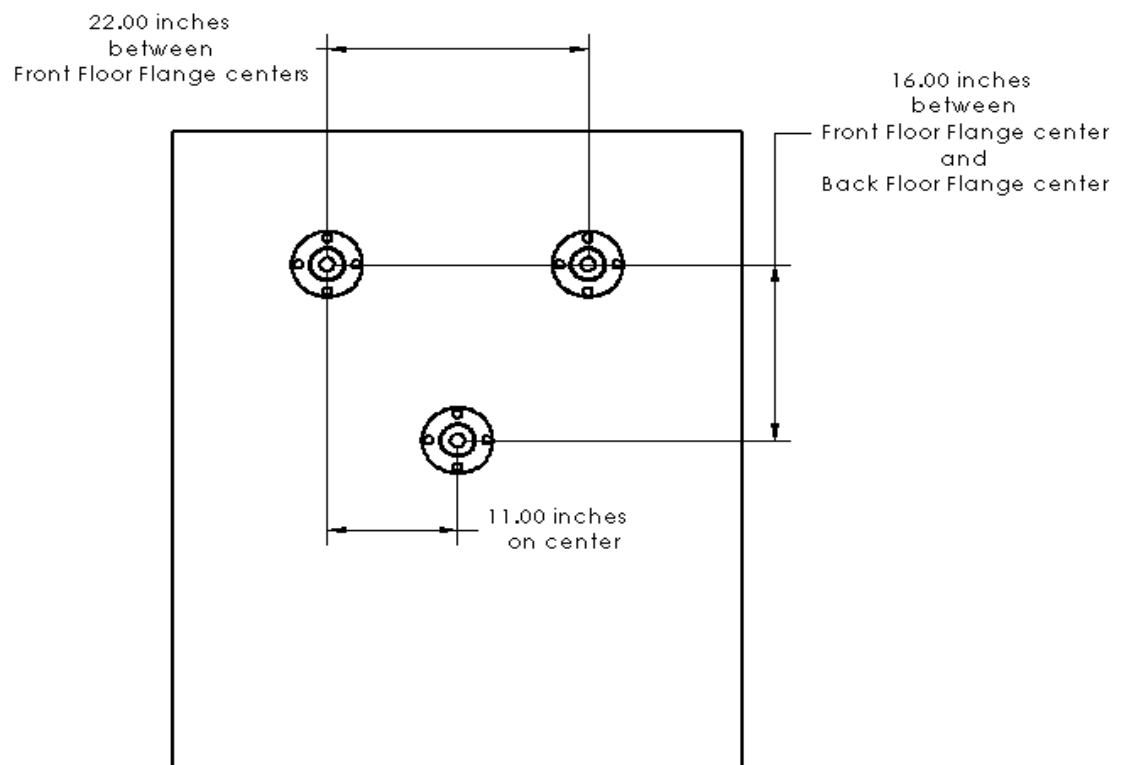

See drawing in Appendix for optional
Four Leg Mounting Frame

Figure 8: Floor Flange Placement

The contractor can mount the floor flanges to the foundation using either cast 3/8 stainless steel threaded anchors into the foundation or use 3/8 inch stainless steel expansion bolts.

The contractor is to supply 2 inch EMT to be used in the Leg Assembly.
The correct cut dimension for the EMT is:

2 Front Legs:

EMT Cut Dimension = Light Beam Center – 16 inches

Or

EMT Cut Dimension = Light Unit Top Surface Height – 19 inches

1 Rear Leg:

EMT Cut Dimension = Light Beam Center – 17 inches

Or

EMT Cut Dimension = Light Unit Top Surface Height – 20 inches

The center of the light beam is 3 inches below the top flat surface of the light unit.

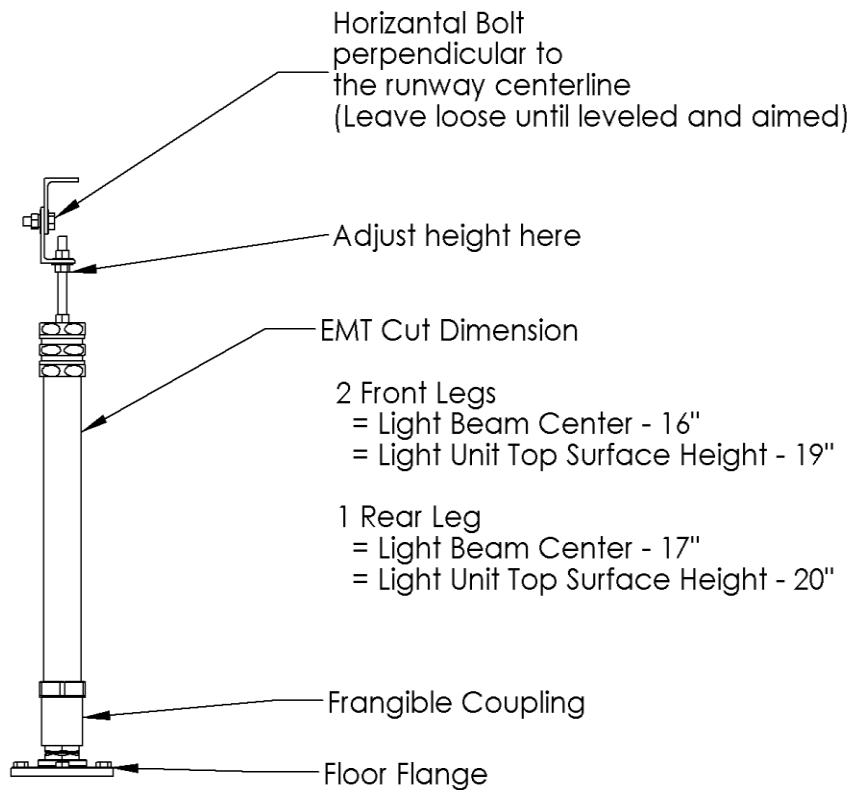

Figure 9: EMT Cut Dimension

When assembling the leg assemblies, keep the top horizontal bolt perpendicular to the runway to allow the light unit to rotate during the aiming process. Remove the light unit cover. Bolt the light unit to the leg assemblies. The Airport Lighting Company light unit was wind load tested at a height of 40 inches.

4.7 Wiring the Light Unit

- Cut the flex tubing that goes from the light unit to the can cover to the proper length. It should be long enough to make the connection easily. This will make it easy to service in the future.
- Fasten the top liquid-tight straight fitting to the PVC Coupling on the bottom of the Light Unit (LU).
- Attach the flex tubing to the bottom liquid-tight straight fitting that is preassembled to the aluminum disk.
- Pass the Light Unit Wire Harness up from the bottom liquid-tight straight fitting.

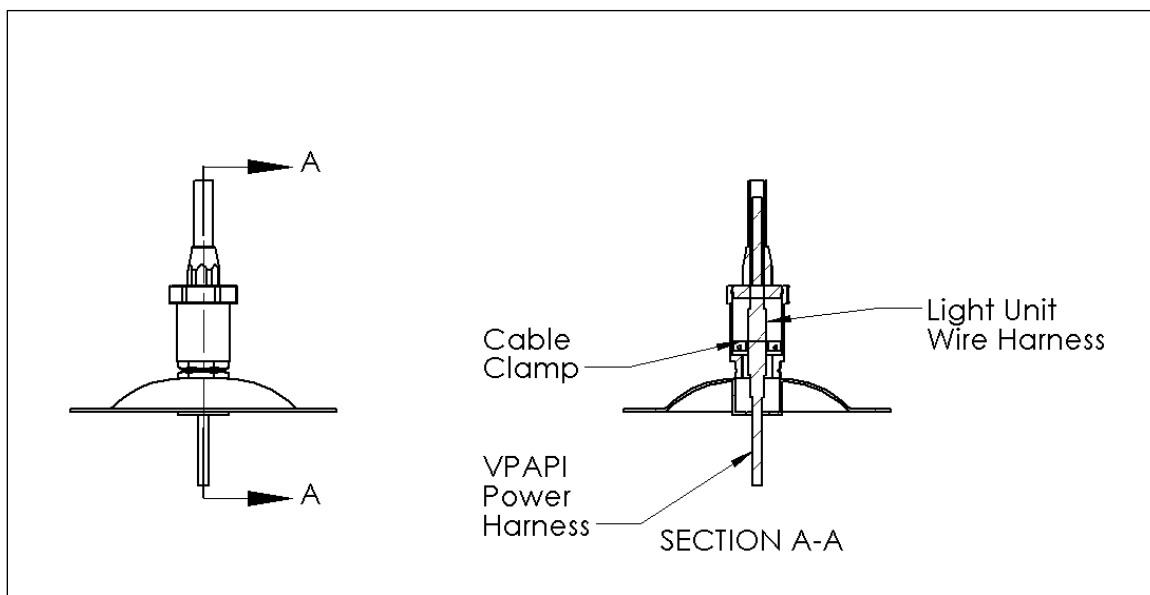

Figure 10: Light Unit Breakaway Plug Connection

- Remove the baseplate from the can.
- Attach a 59B frangible coupling to the baseplate.
- Connect the VPAPI Power Harness to the Light Unit Wire Harness
- Attach the cable clamp to the VPAPI Power Harness so that the top of the cable clamp lines up with the joint of the VPAPI Power Harness and the Light Unit Wire Harness.
- Pass the (4pin female/ cut end) VPAPI Power Harness through baseplate so that the 4 pin female connector is on top of the lid.
- Pass the Light Unit Wire Harness up through the light unit and secure the liquid-tight

straight fitting to the bottom of the light unit.

- Fasten the straight fitting connector disk to the frangible coupling.
- Check that all connections are secure and no extra wire is needed.
- Tighten the strain relief on the inside of the light unit
- Measure the wire coming out of the strain relief and cut it at 7".
- Remove the outer jacket from the wire, back 6".
- Strip each of the four wires 3/8" and crimp on the blue fork terminals.
- Attach each fork terminal to the terminal block as per Figure 11
- In the can, attach the red and brown wires to the series Tilt loop. Attach the power connections to the black and white wires in a parallel circuit. See wiring diagram, Figures 14 and 15.
- Once all wiring is complete secure the cans and secure the LU cover.

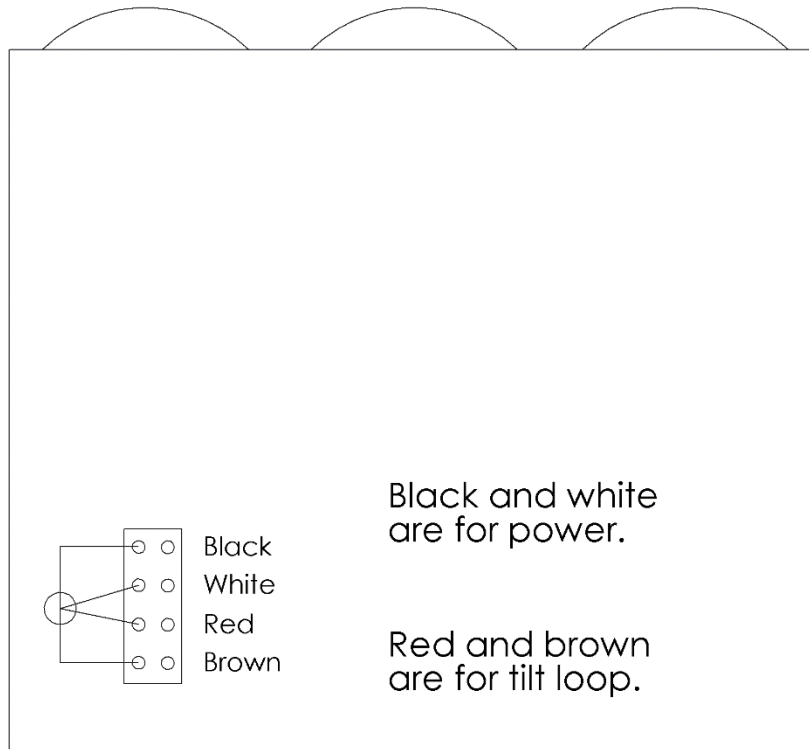

Figure 11: Light Unit Wiring

4.8 Power and Control Unit Electrical Hookup

CB1 is the breaker for the incoming power. The breaker should be in the off position before power is connected. The two line leads go to the breaker and the ground is hooked up to the ground lug next to the breaker.

Output terminal block (TB1) at the large transformer (T1) has two line outputs and common in the center. For the L880 Style A PAPI with four light units, two light units are wired in parallel to Out 1 and Common, two light units are wired in parallel to Out 2 and Common. By wiring light units 1 and 4 on one circuit and 2 and 3 on the other circuit, a second level of safety is provided. Should either circuit fail for any reason, the signal to the pilot is still good. (See figure 10) For the L881 Style A PAPI with two lights units, one light unit is wired to L1 and Common, and one light unit is wired to L2 and Common.

Input terminal block (TB3) is used for the input of the tilt loop, the interlock detection, and the remote control.

The tilt loop is a 14 AWG or larger series loop that goes from the PCU to the light units. Should any light unit get out of tilt, the Digital Aiming Tilt Sensor in the light unit will send a switch open signal to the PCU.

The Runway Lights Interlock is an elective feature that will provide a signal to the PCU when the runway lights are turned on. To install the runway lights interlock, place a 10 watt isolation transformer on the runway lights series circuit. Connect the output of the 10 watt transformer to the Runway Lights Interlock at TB3. (See Sections 6.2, 6.6)

The Remote is an elective feature designed to turn the PAPI unit on by remote control. Connect the output of a remote control system to the Remote at TB3. When the remote control provides a switch closure, the PCU will turn the PAPI lights on. When the remote control provides a switch open, the PCU will turn the light units off. (See Section 6.2)

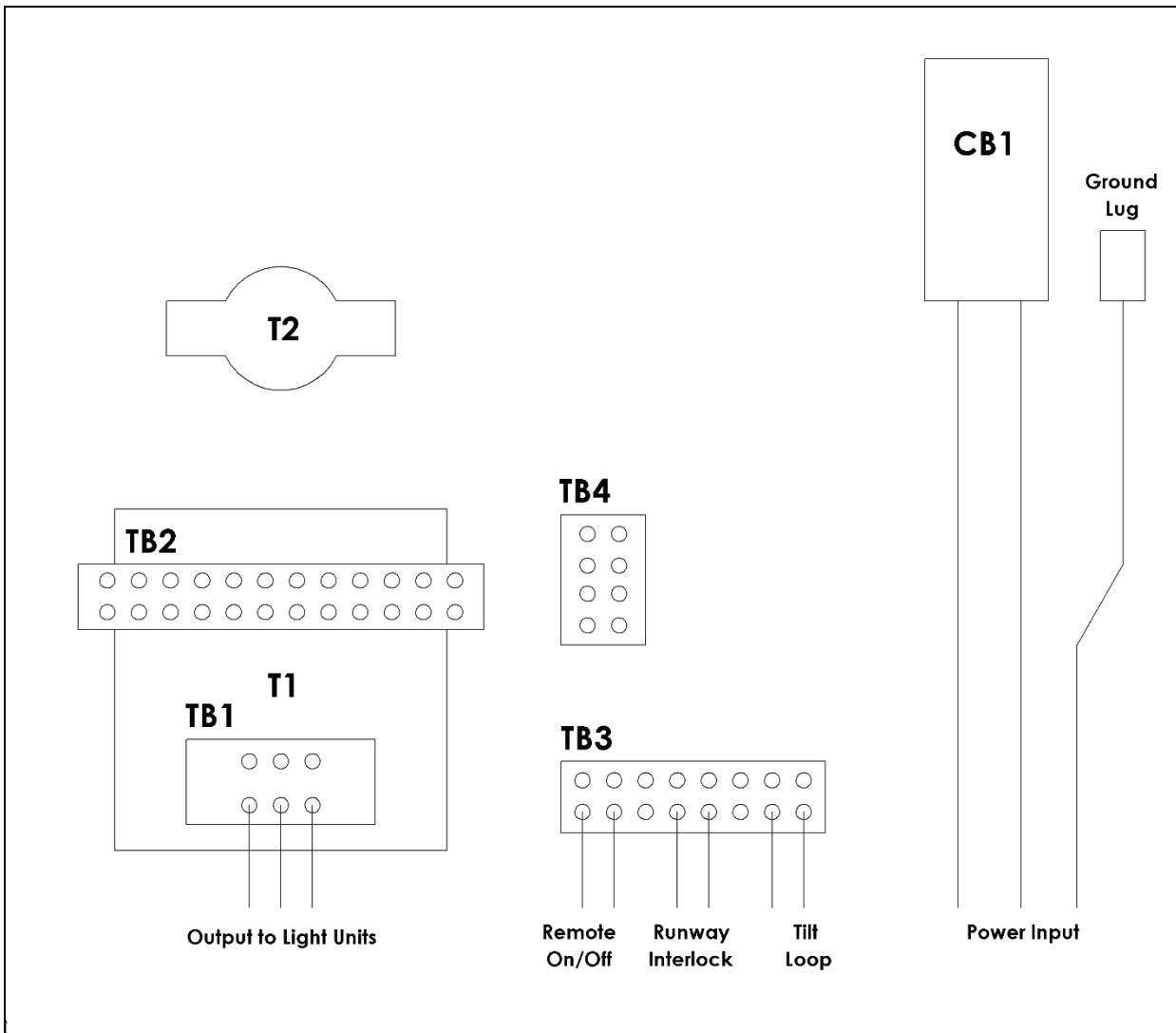

Figure 12: Power Control Unit Electrical Hook-up

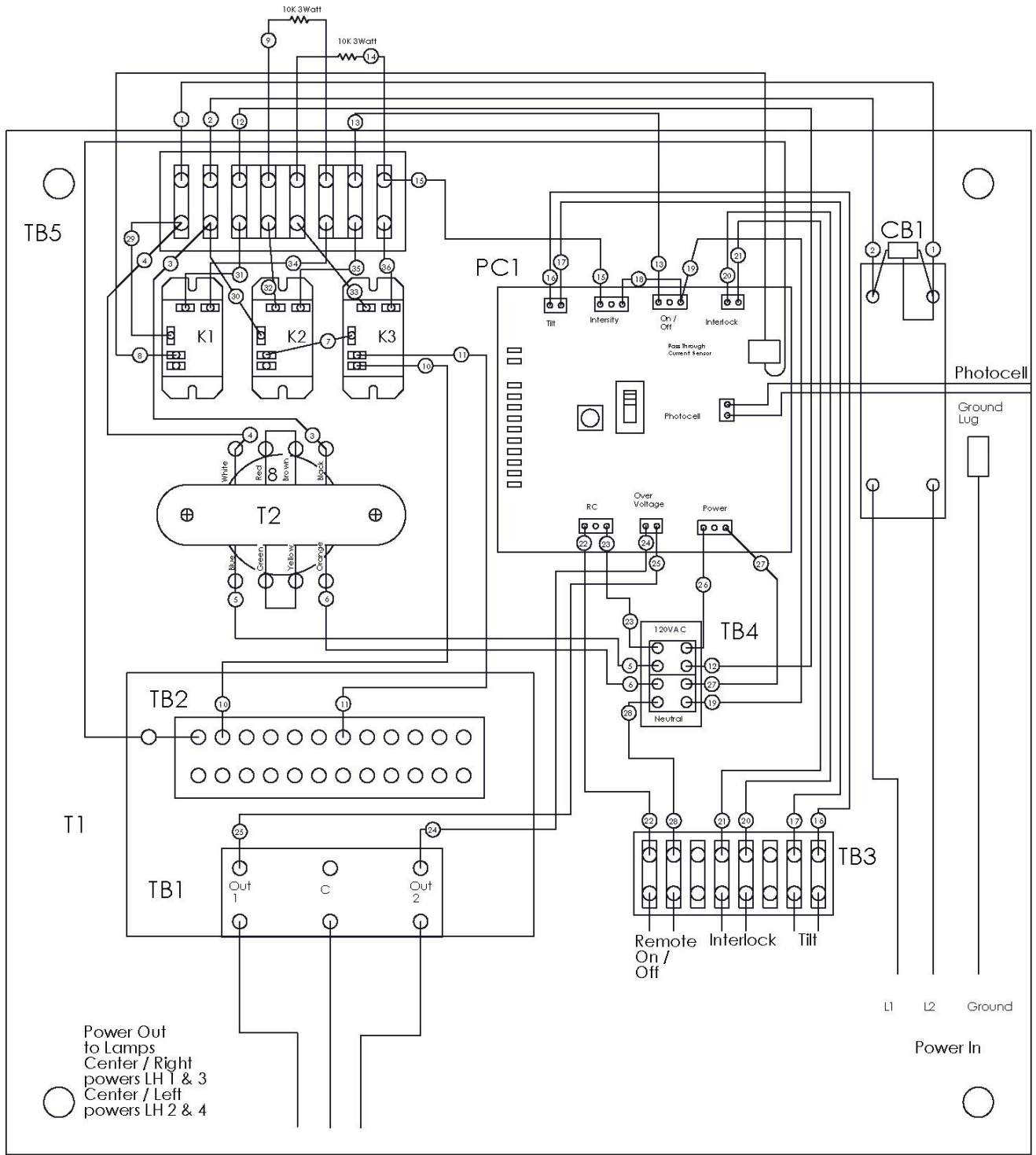
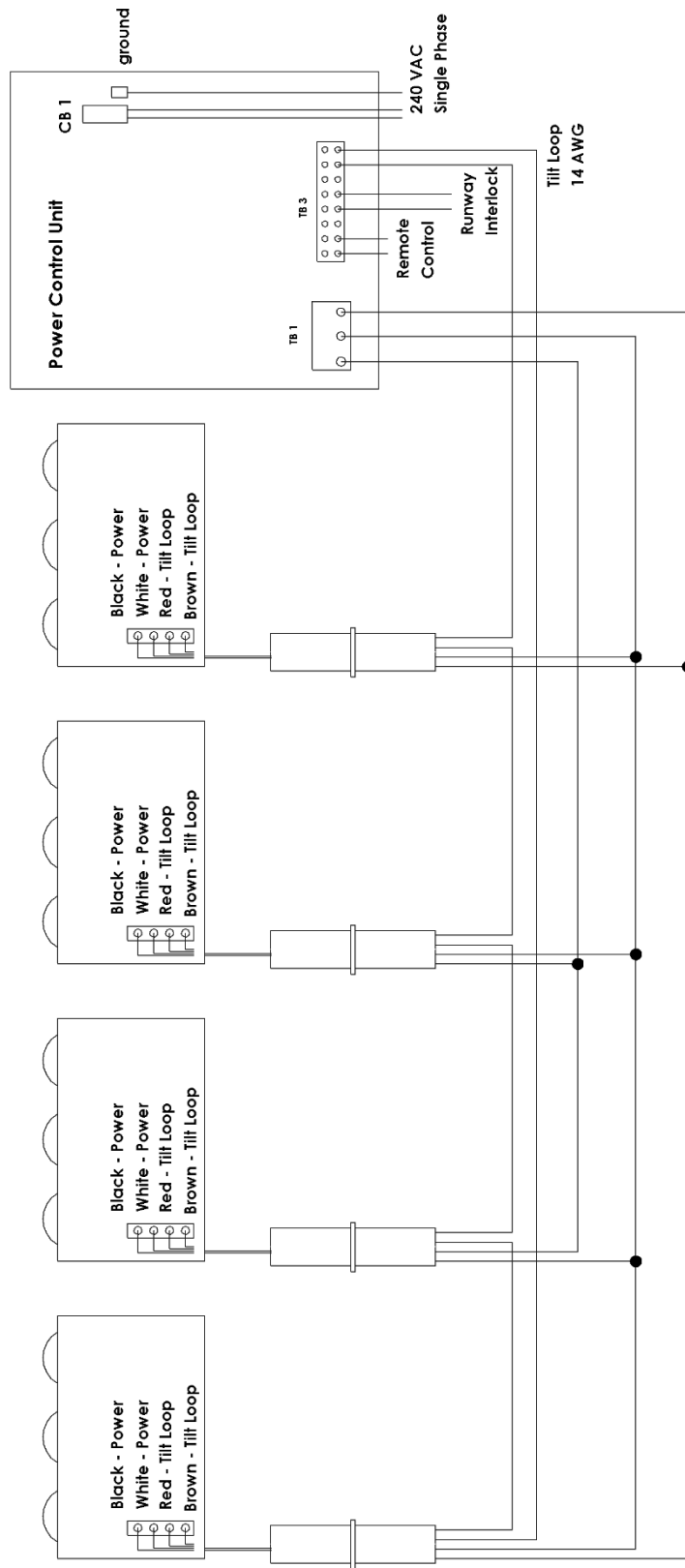

Figure 13: Power Control Unit Wiring Diagram



This wiring diagram shows light unit 1 and 4 on one loop and light units 2 and 3 on a second loop. This provides an added level of security. Should one loop fail, the system can provide a good signal using the two light units on the remaining loop.

Figure 14: L880 Style A, Wiring Diagram

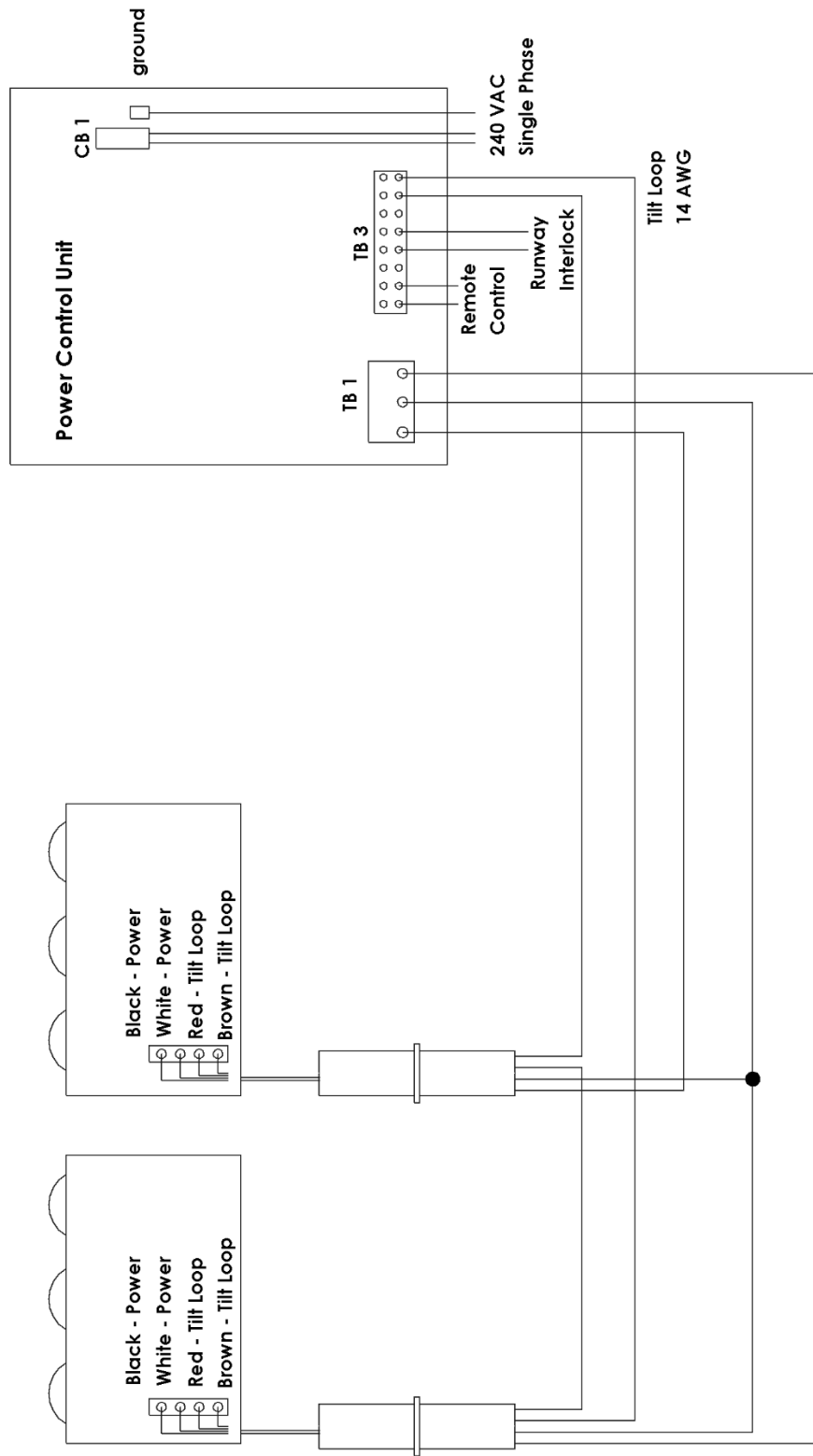

Figure 15: L881 Style A, Wiring Diagram

5.0 Aiming

The light units are pre-focused at the factory. The beam of light produced by each light unit comes straight out and is parallel to the bottom surface of the light unit. In order to create the light pattern that provides a signal for the pilot, the light unit is leveled side to side by adjusting the height of the front legs, and aimed at a precise angle, by changing the height of the rear leg(s),

5.1 Digital Aiming Tilt Sensor

The Digital Aiming Tilt Sensor, DATS, is an electronic angle indicator tool used to set each light unit at the correct aiming angle and to switch the PAPI off if the light unit is out of tilt. The digital readout on the DATS is in degrees and minutes. The DATS is powered by the PAPI electrical system or by a 9 volt battery if power is not available at the time of installation. The DATS works by displaying the aiming angle of the light unit. The light unit's aiming angle is adjusted at the threaded rod until the display on the DATS matches the desired aiming angle. Once the aiming angle is reached the tilt function needs to be set so that it will determine if the light unit is out of tilt (see 5.2). Once the aiming angle is electronically recorded the DATS will monitor the aiming angle and determine if the light unit is within range or out of tilt.

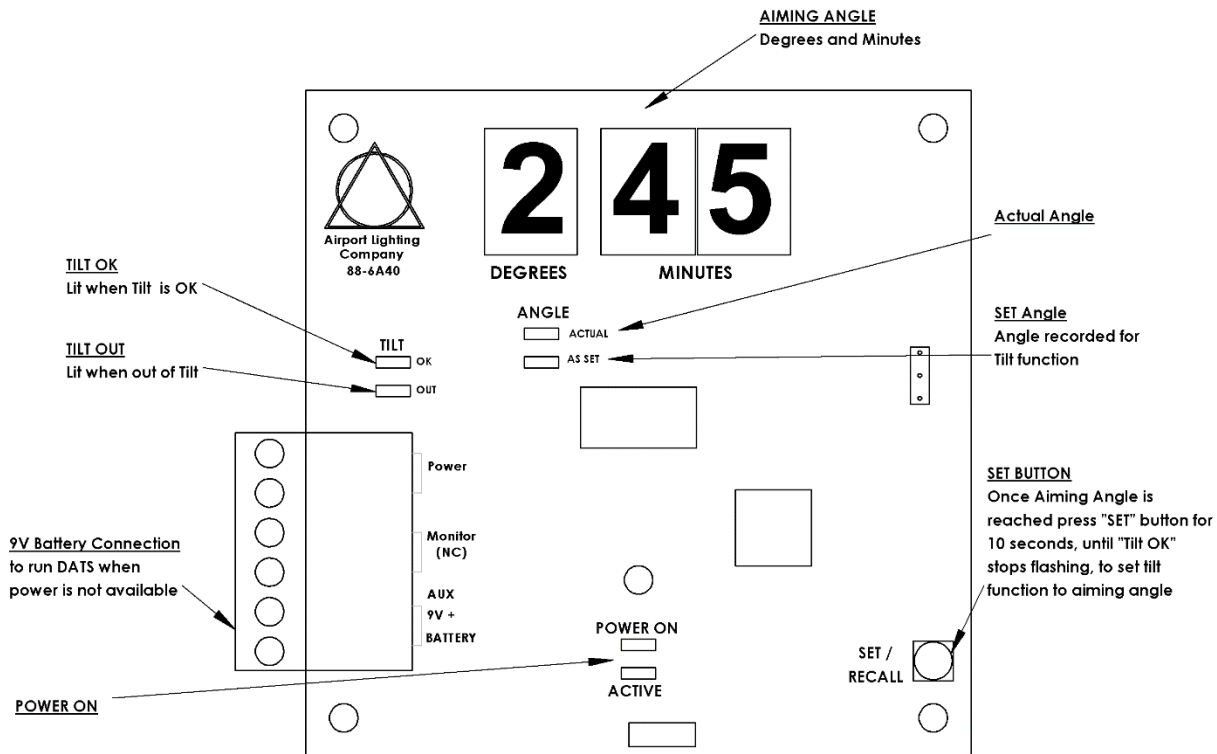

Figure 16: Digital Aiming Tilt Sensor, DATS

5.2 Aiming Angle

The Aiming Angle is the angle above horizontal plane at which the light unit is aimed. The unit closest to the runway will have the largest Aiming Angle, the Aiming Angles will then recede in value with the unit farthest from the runway having the smallest value. The Aiming Angles should be listed on the PAPI site drawings. If the aiming angle is not provided in the site drawings contact your airport engineer and check section 3 in this manual, "FAA Siting Considerations. "

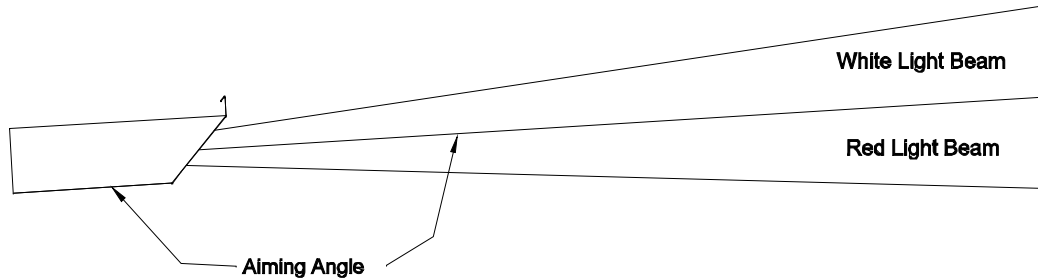

Figure 17: Aiming Angle

Aiming Angles are referred to in degree and minutes. *Note that the symbol for minutes is the same as the symbol for feet.* When working with the PAPI system, if you see the ' symbol always check if to see if it is a reference to a distance in feet or an angle in minutes. This manual will always write out degrees and minutes to eliminate any confusion.

Two degrees 50 minutes is written: $2^{\circ} 50'$ (2 degrees 50 minutes)

If you need to convert from degrees in decimal to degrees and minutes use the formula below.

To convert from decimal to minutes multiply the decimal value by 60;

$$0.5 \text{ degree} * \frac{60 \text{ minutes}}{1 \text{ degree}} = 30 \text{ minutes}$$

$$2.83 \text{ degrees} = 2 \text{ degrees} + (0.83 \text{ degree} * \frac{60 \text{ minutes}}{1 \text{ degree}}) = 2 \text{ degrees } 50 \text{ minutes}$$

5.3 Aiming the Light House Unit

Once the Light Unit is fully assembled and mounted on the slab, it needs to be carefully aimed.

- Disconnect Power to the Light Units
- Remove the Light Unit Covers
- Loosen the horizontal bolts at the angle brackets just enough to allow the brackets to rotate freely.
- Level all the units to the same horizontal plane (see section 3 for initial installation)
- Once all the units are on the same horizontal bar each light unit can be aimed.
- Set the light unit level side to side by adjusting the leg heights until it is level.

Adjust the leg heights until the light unit is level side to side

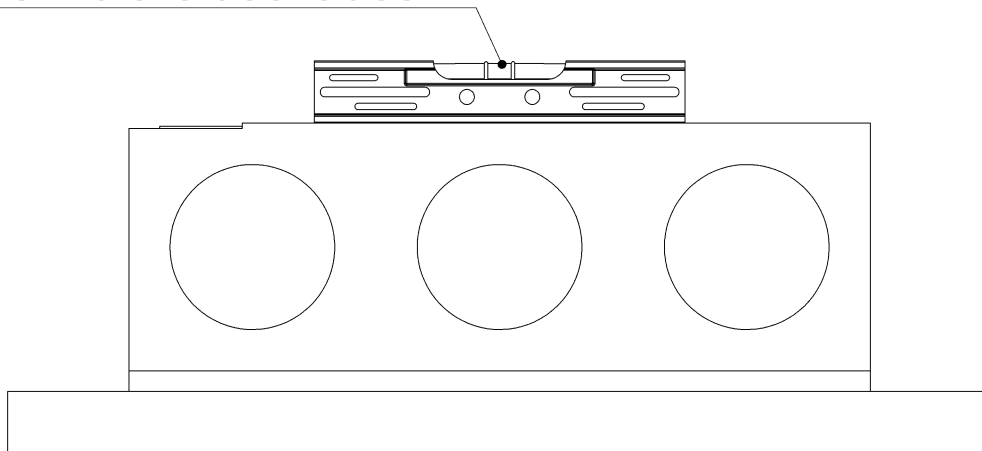

Figure 18: Front View, Leveling

- Adjust the height of the nuts on the two front threaded rods at the angle brackets to adjust the side to side leveling.
- There are 3 ways to provide power to the Digital Aiming Tilt Sensor, DATS, during the aiming process.
 - o A 9 volt battery can be used at any time to power the DATS if power is not available. The 9 volt battery connects to the DATS in any light unit.
 - o Local Control Override button on the circuit board inside the Power Control Unit can be pressed to provide 5 minutes of unmonitored power. It can be pressed every 5 minutes.
 - o A temporary jumper can be installed in the Power Control Unit at TB3 Tilt. **The jumper must be removed** when the aiming is complete and the tilt loop circuit must be reconnected.

L880-81 VPAPI Style A Light Unit Wiring Diagram

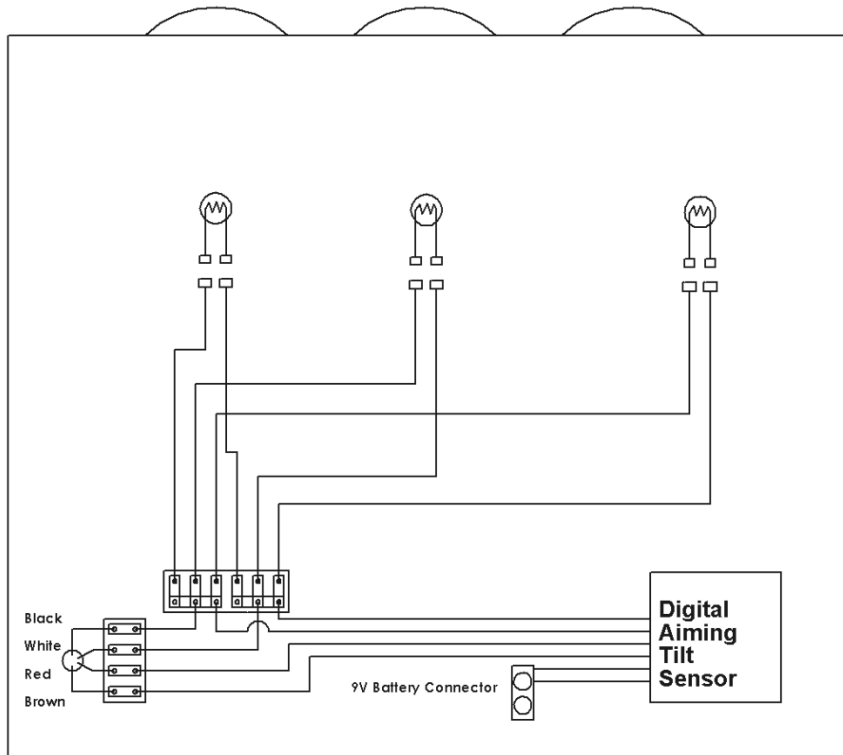

Figure 19: Powering the Digital Aiming Tilt Sensor

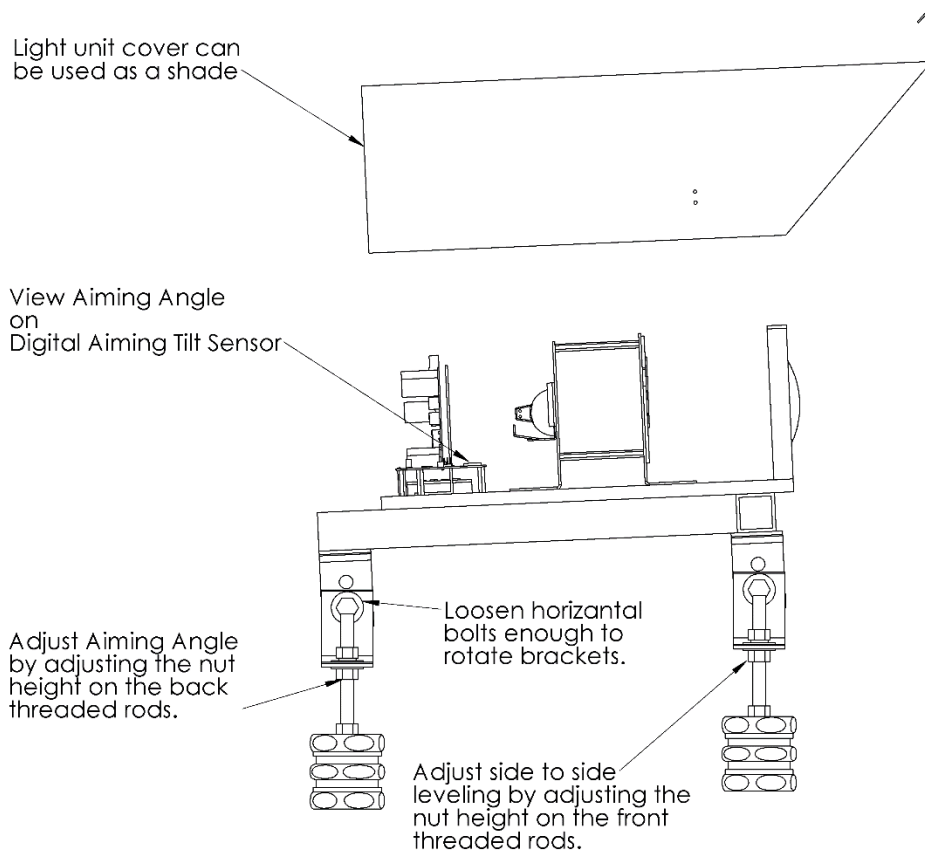

Figure 20: Side View, Aiming Adjustment

- Adjust the nuts on the rear threaded rod to adjust the Aiming Angle. If you adjust the front nuts, you risk throwing off the Side to Side leveling and falling off the horizontal plane on which all the light units lie.
- Once the Aiming Angle is set, re-check the Side to Side leveling.
- Secure all bolts and double check the Aiming Angle and Side to Side Leveling.
- Once aiming is complete, press and hold the “Set” button on the Digital Aiming Tilt Sensor to record the correct aiming angle. Press and hold for 10 seconds. When the Tilt OK LED stops flashing the unit will display the recorded aiming angle being used by the tilt function. A momentary press of the set button will display the recorded aiming angle. Releasing the set button will display the current position of the light unit.
- If a 9 Volt battery was used to power the Digital Aiming Tilt Sensor remove it at this time.

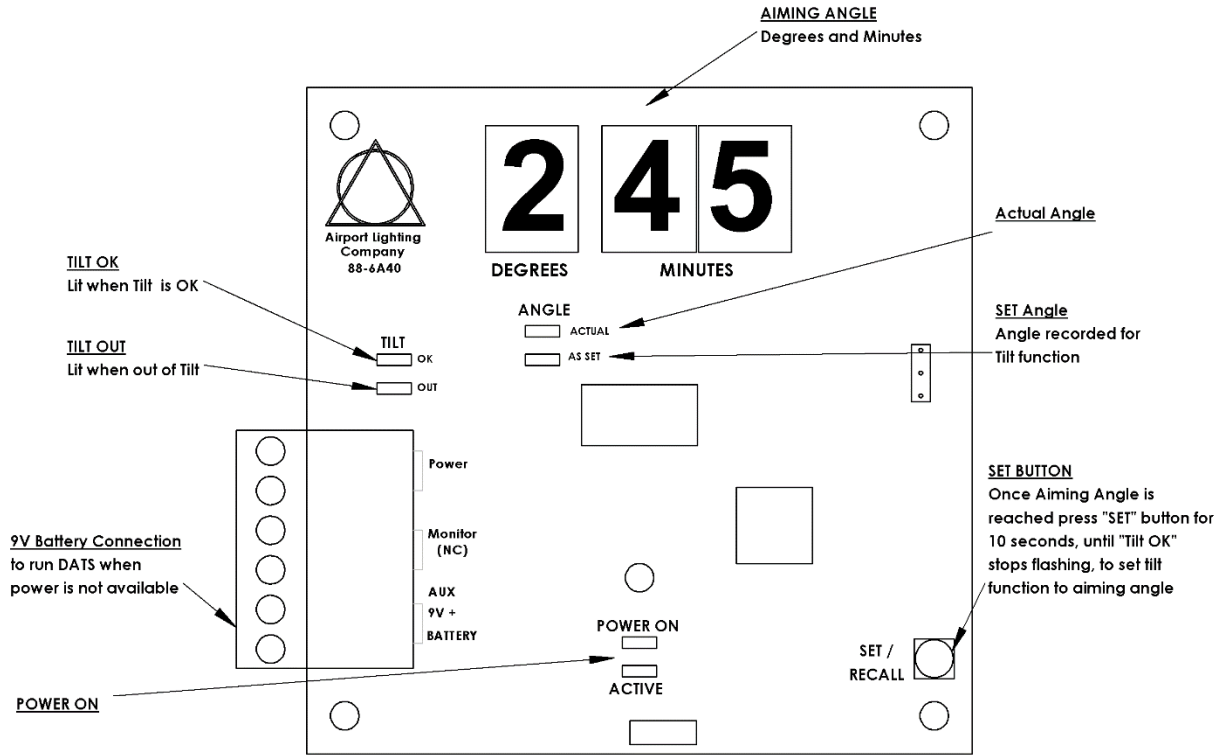

Figure 21: Digital Aiming Tilt Sensor

- Replace the Light Unit Cover and secure the four hold down clips.
- Once all Light Units have been aimed, restore power to the PAPI system.
- Check that all lights come on.

6.0 Power Control Unit

The Style A PAPI systems use a Power Control Unit (PCU) to control the operation of the PAPI system.

The PCU has the ability to;

- Control the intensity of the light units by sensing if it is day or night.
- Check light unit tilt status of all the light units
- Check for over-voltage, to protect lamp life.
- Determine if a lamp is out
- Turn on or off by remote
- Turn on or off with runway lights at night

6.1 Power Control Module LED Indicators

The printed circuit board inside of the PCU has a row of LED indicators to provide feedback on the PAPI system. There is also a reset button which provides Local Control, a Low Intensity Selector switch which is used for calibrating and a jumper (JP1) which is used for activating the runway lights interlock detection.

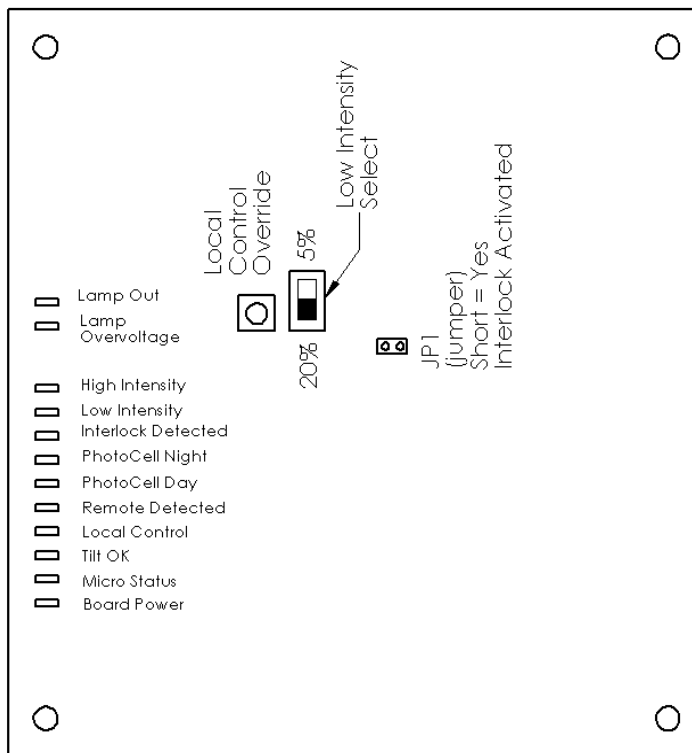

Figure 22: Voltage PAPI LED Information

VOLTAGE PAPI LED INDICATORS

Lamp Out:	After initial calibration of PAPI PCU (see instructions section 6.3) this LED will light if one or more lamps in any of the light units are not working.
Lamp Overvoltage:	This LED will light if the PAPI is putting out too much power to the lamp circuit, a condition which will reduce lamp life. It will aid in selecting the proper tap on the power transformer to adjust for variations in voltage from the designed input of 240 volts. (See instructions section 6.2)
High Intensity:	This LED indicates that the PAPI is operating at its high intensity (day) lamp brightness mode.
Low Intensity:	This LED indicates that the PAPI is operating at low intensity (night) lamp brightness mode.
Interlock Detected:	This LED indicates that the optional runway interlock feature is detected. It will light if the PAPI detects a signaling output from an isolation transformer connected to the series circuit for the runway lights. (See section 6.5)
Photocell Night:	This LED indicates that the photocell detects night conditions which would warrant low intensity lamp brightness mode. This function has delay.
Photocell Day:	This LED indicates that the photocell detects day conditions which would warrant high intensity lamp brightness mode. This function has delay.
Remote on Detected:	This LED indicates that the PAPI senses the presence of a signal from a remotely located on-off switch.
Local Control Override:	This LED indicates that the PAPI is operating through the use of the local control switch located on the printed circuit board inside the power and control unit. (See section 7.3)
Tilt OK:	This LED indicates that all of the light units for the PAPI are within the allowed tolerance of their aiming angle. When not illuminated, check each of the light units for proper aiming and/or tilt switch setting. (See section 7.4) (A 9V battery can be used to power the Digital Aiming Tilt Sensor when power is not available or when the PCU has turned off the lights)
Micro Status:	This LED indicates that the processor on the printed circuit board in the PCU is working.
Board Power:	This LED indicates that power is getting to the printed circuit board in the PCU.

6.2 How the Power Control Unit Electronic Functions Work

The Voltage PAPI has a printed circuit board in the power control unit that performs a number of functions. There is a program stored in the printed circuit board and some calibrated values that help provide information. The following functions are described in the same order as the LED indicators on the printed circuit board.

Lamp Out

The Lamp Out function works by measuring the amperage going into the primary transformer, T1. If the amperage decreases below the calibrated value it will signal a lamp-out. This function works at both high and low intensity. In order for the Lamp Out function to work in low intensity the low intensity selector switch, "SW2 Low Intensity Select", must be on the same selection as the low intensity tap going into the primary transformer. If the low intensity tap goes into 5% low intensity, then the selector switch must be set to 5% in order for the lamp out function to work properly.

Lamp Overvoltage

The Lamp Overvoltage function works by measuring the primary transformer output across Out 1 and Out 2. This value is compared to a factory setting. If the value exceeds the factory setting the high intensity tap can be moved down until the Lamp Overvoltage LED no longer comes on at high intensity. Once the correct high intensity tap is selected, the printed circuit board will need to be recalibrated in order to reset the correct amperage settings for the Lamp Out function.

High Intensity / Low Intensity

The VPAPI provides high intensity for day time operation and low intensity during night time operation. When running under high intensity the High Intensity LED will come on and vice versa. The switching from high intensity to low intensity is controlled by the photocell. There is a 1 minute delay in this function. The printed circuit board must see the photocell night setting continuously for 1 minute before the LED and circuit switch to the low intensity setting. The 1 minute delay works in both directions, from day to night and night to day. The 1 minute delay is used to take into account clouds, and short term light disruptions.

Interlock Detected.

This function is used to enable PAPI night operations only when the runway lights are on. This function works in night mode. During daylight hours, Photocell Day, this function is not detected. In order for this to work, a jumper needs to be in place on the printed circuit board at "Interlock Activated." The output from a 10 watt isolation transformer, connected to the runway lights series circuit, needs to be connected to the PCU at the Runway Lights Interlock at TB3. When the PCU is powered up and a jumper is in place, the system will go on and off with the runway lights at night. Day operation is not affected by the interlock.

Photocell Day / Photocell Day

The LEDs for Photocell Night and Photocell Day switch instantaneously per the photocell

reading mounted to the outside of the PCU, even though a change in brightness levels will occur only after a time delay. During the day the photocell can be covered to see the LED switch, at night a flashlight can be used to check the photocell. The connection of the photocell to the printed circuit board must be done in the field to facilitate shipping. If the photocell does not work properly check the connection at the printed circuit board. There is a small lip in the plug which needs clip under the plug on the printed circuit board. The photocell sends a signal to the printed circuit board.

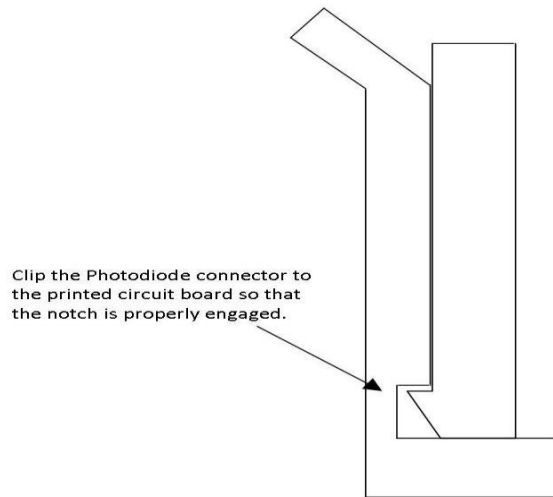

Figure 23: Photocell Printed Circuit Board Connection

The printed circuit board has a 1 minute delay before switching from high intensity to low intensity. (see High Intensity / Low Intensity above)

Remote Detected

This will turn on the light units when a switch wired to “Remote Control” at TB3 is in the switched closed position. If the switch is in the open position the lights will go off. If a remote control is not used, a jumper must be placed across “Remote Control” at TB3. A jumper will be installed on all PAPI power control units leaving the factory. The jumper across Remote Control at TB3 will need to be removed to install a remote control.

Local Control Override

This feature is in place to allow the light units to be powered by maintenance personnel. Its primary function is to allow the light units to be powered without regards to the tilt status. This is necessary because without power to the light units, maintenance personnel would not be able to check the LEDs on the Digital Aiming Tilt Sensor at each light unit. The Local Control Override always operates at high intensity. To activate Local Control, press the Local Control momentary switch on the printed circuit board. This will light the Local Control LED on the printed circuit board, will allow the system to function without a good tilt signal, and will switch to high intensity. The Local control override can be turned off by pressing the momentary switch. If left on, the Local Control Override will function for 5 minutes. Once the 5 minutes are up the system will return to normal function. The Local Control Override can be pressed again after it has returned to normal operation.

Tilt OK

This LED will come on if a series loop connecting all the light units' Digital Aiming Tilt Sensor provides a good signal. Should any light unit be knocked out of tilt, the Digital Aiming Tilt Sensor will send a "switch open" signal and will turn off the LED on the PCU. Once the Tilt OK LED has been off for 20 seconds, the printed circuit board will shut down power to the light units. If the Tilt OK LED is off, the Local Control Override can be used to provide power so the tilt status of each Digital Aiming Tilt Sensor can be examined. Once the Tilt OK LED has gone off, the printed circuit board will not allow the system to come back on for normal operation. To return to normal operation the system must be rebooted by turning the circuit breaker off, wait for a few seconds and turn the circuit breaker back on.

Micro Status

This flashing LED indicates that the processor on the PC board in the PCU is working properly.

Board Power

This LED indicates that the PC board in the PCU is getting power. This LED is a reminder that power is on at the PCU even though the light units may be out.

6.3 Adjusting the High Intensity Output Voltage of the PCU

It is necessary to look at the voltage seen by the PAPI lamps. If the voltage is too low the light intensity will be diminished. If the voltage is too high the lamp life will be diminished. The transformer in the power control module has 9 Day taps each of which provide 2.5% of adjustment. The following is a procedure for checking and adjusting the output voltage

- 1) Measure the lamp voltage at the light unit closest to the power and control unit (PCU).
- 2) The lamp voltage at the light unit closest to the PCU should be 15.9 Volts.
- 3) If the lamp voltage exceeds 15.9 Volts, **turn the breaker off** and move the tap down (to the left). Each 2.5% adjustment will decrease the voltage by approximately 0.4 volts.
- 4) If the voltage is too low at the light unit **turn the breaker off** and move the tap up (to the right). Each 2.5% adjustment will increase the voltage by approximately 0.4 volts.
- 5) After moving the tap, always recheck the voltage seen by the closest lamp.
- 6) Once the correct tap is selected, it is necessary to recalibrate the PCU printed circuit board. (See section 6.4)

6.4 Calibrating the PCU Printed Circuit Board

Once the correct tap is selected and the light units are seeing the correct voltage, it is necessary to calibrate the Power and Control Unit (PCU). Calibrating the PCU will allow the PCU to be able to determine if there is a lamp out. If the high intensity tap was not moved from the “Norm” position no calibration is necessary. Any time the high intensity tap is moved to a new location, a calibration is required.

- 1) Wire tap at large transformer (T1) for 20% Night, low intensity. Make sure the Low Intensity Select switch on the printed circuit board is switched to 20%.
- 2) Hold “Local Control Override” button for 15 seconds on power up. Low intensity lights come on and stay on for 2 seconds. You can stop pressing the button.
- 3) When low intensity lights go off, change the tap at the large transformer (T1) to 5% Night, low intensity. Change Low Intensity Select switch on the printed circuit board to 5%. As soon as the switch is moved, low 5% intensity lights come on for 2 seconds. Then high intensity lights come on for 2 seconds. Later all the lights go off and the main working algorithm starts to run.

6.5 Adjusting the Low Intensity Output Voltage of the PCU

The PAPI system operates at two different light intensities. High intensity is used during the daytime and low intensity is used at night.

At rural airports, where there is very little ambient light, use the 5% night tap. This will produce a lower Low Intensity output.

At urban airports, where there is a large amount of ambient light, use the 20% night tap. This is will produce a higher Low Intensity output.

6.6 Installing a Runway Lights Interlock

The Style A PAPI systems have runway lights interlock capabilities. The runway lights interlock is a system that allows night operation of the PAPI only when the runway lights are in use. The runway lights interlock system senses if the output from a 10 watt transformer in the runway lighting circuit is present at the runway lights interlock input of the PCU at TB3. The runway lights interlock function requires a jumper (supplied) at JP1 on the PCU printed circuit board. When the interlock is in use, power is always delivered to the PCU. The PCU will decide when to turn on the relay switches which operate the light units by sensing the interlock status. Maintenance personnel can test this feature and observe whether the PCU can see the runway lights interlock by checking the PCU’s LED “Interlock Detected.”

6.7 Installing the Photocell Light Detector

The photocell needs to be installed and aimed. Connect the photocell to the PCU enclosure securely. (See figure 14) Loosen the set screw on the photocell assembly and aim the arrow on the top of the photocell north. Secure the set screw. Fasten the photocell connector to the PCU printed circuit board. Make sure that the terminal is oriented in the correct direction. (See figure 15)

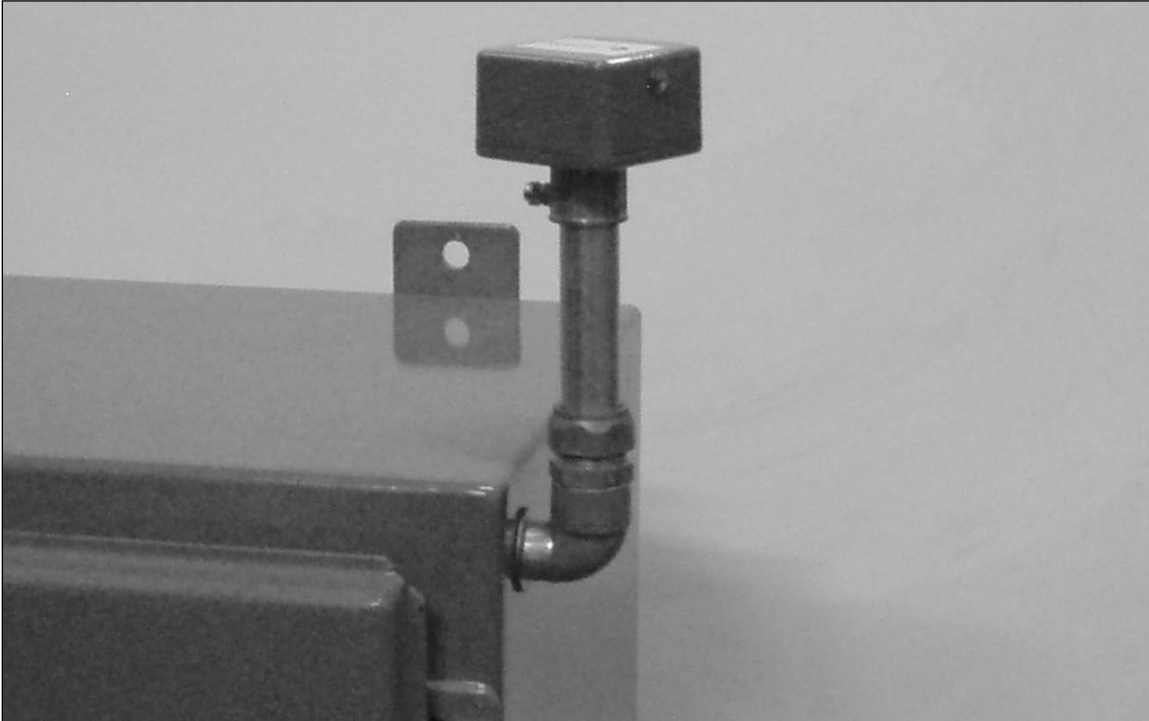

Figure 24: Photocell Mounting

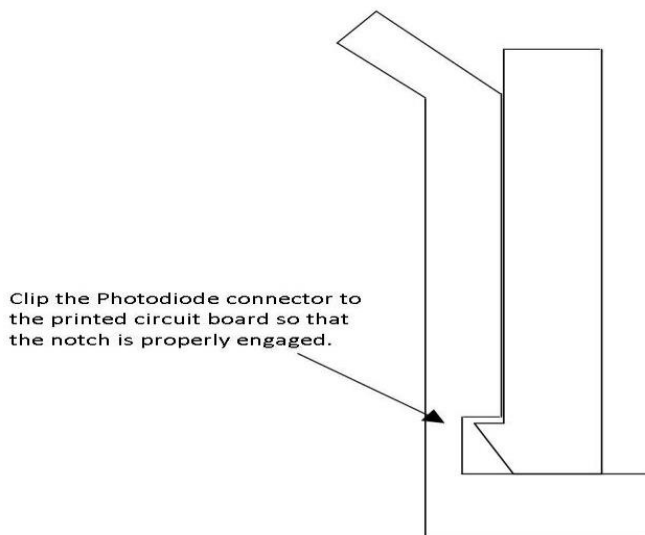

Figure 25: Photocell PCB Connector

7.0 Operating Instructions

- 7.1 Basic Maintenance
- 7.2 Replacing a Lamp
- 7.3 Local Control Override
- 7.4 Troubleshooting System Out of Tilt
- 7.5 Replacement Parts

7.1 Basic Maintenance

A regular inspection should be made to ensure that all lamps are working. Maintenance that can be performed in the field include: lamp replacement, PAPI re-alignment and tilt adjustment, lens cleaning, electrical hook up. Airport Lighting Company requests that PAPI units requiring lens or filter replacement be returned to the factory. For any other maintenance issues please contact the factory for further instructions.

External Maintenance

The basic external maintenance includes checking that all three lamps in each unit are working properly, cleaning the lens with a window cleaner, checking all electrical junctions are secure, and checking that each leg assembly is firm and secure.

Internal Maintenance

Internal maintenance should be done when it is required to change a lamp or reset a Digital Aiming Tilt Sensor. Use a window cleaner to clean the inside surfaces of the clear lens and the red filters. Wiring can be inspected and the fasteners mounting the Main Plate to the Mounting Frame can be checked.

7.2 Replacing a Lamp

Replacement lamps can be ordered from the factory, it is recommended to keep a few in stock for quick replacement. The Airport Lighting Company replacement lamp is part number 106.

Note which lamp needs to be replaced, (you may decide to mark below lens with the piece of tape so you can identify the correct lamp when power has been removed).

Disconnect power to the PAPI

Remove the Light Unit cover.

Disconnect the lamp terminals

Use the lever on the side of the lamp holder to push the lamp up

Remove the old lamp

Push the lever back before installing a new lamp

Slide the new lamp into the lamp holder until it touches the bottom.

Reconnect the lamp terminals.
Lenses and filters can be cleaned at this time with a glass cleaner.
Reinstall the PAPI Cover and secure the four latches
Return power to the PAPI.
Check that all lamps are working

7.3 Local Control Override

The Local Control Override is a function that allows maintenance personnel to provide power to the light units when a light unit is out of tilt or something is not working properly. This is necessary in order to provide maintenance the ability to inspect the Digital Aiming Tilt Sensors and the light units to determine where there is a problem. In order to use the Local Control Override, press the Local Control Override momentary switch down on the PCU's printed circuit board until the light units come back on. The Local Control Override always operates at high intensity. To turn the Local Control Override off press the momentary switch again. The Local Control Override will provide power to the light units for 5 minutes. When the light units turn off the system returns to normal operation, the Local Control Override can be pressed again to run the lights for 5 more minutes. The 5 minute run time is in place to provide maintenance the power they need and also to insure the system is not left on when it is out of tilt or not working properly.

7.4 Troubleshooting System Out of Tilt

The PAPI system is designed to shut down if one of the light units is out of tilt. This is to ensure that the pilot does not receive an incorrect signal. On the Style A PAPI system there is a series of red LED indicators on the printed circuit board inside of the Power and Control Unit. If the red LED, labeled "Tilt OK", is off it means that the one or more of the light units is out of tilt.

- Check power to the PCU, LED indicator labeled "Board Power"
- If the PCU has power and the LED indicator "TILT OK" is off, it means that the tilt loop has shut the PAPI system down.
- Visual check to see if any of the units are out of tilt.
- Remove power from the PAPI and remove the cover of the unit out of tilt.
- If you have not identified the unit out of tilt, remove all of the PAPI covers and restore power to the PAPI system.
- Press the Local Control Override momentary switch on the PCU's printed circuit board, to provide power to the light units, so the LEDs on the light unit Digital Aiming Tilt Sensors can be observed. (see section 7.3)
- Look at each Digital Aiming Tilt Sensor. (refer to figure 26)
 - o No POWER LED on and no ACTIVE LED flashing, means no power to the tilt switch.
 - o Red TILT OUT LED on, POWER LED on and ACTIVE LED flashing, means system has power and is out of tilt.
 - o Green TILT OK LED on, POWER LED on and ACTIVE LED flashing, means system has power and is working properly.

- Re-Aim the light unit, recheck side to side aiming, recheck the aiming angle.(see Aiming in Section 3.2)
- Reboot power to the PAPI system and make sure the green TILT OK LED is on, POWER LED is on and ACTIVE LED is flashing.
- Check that all lights are working properly

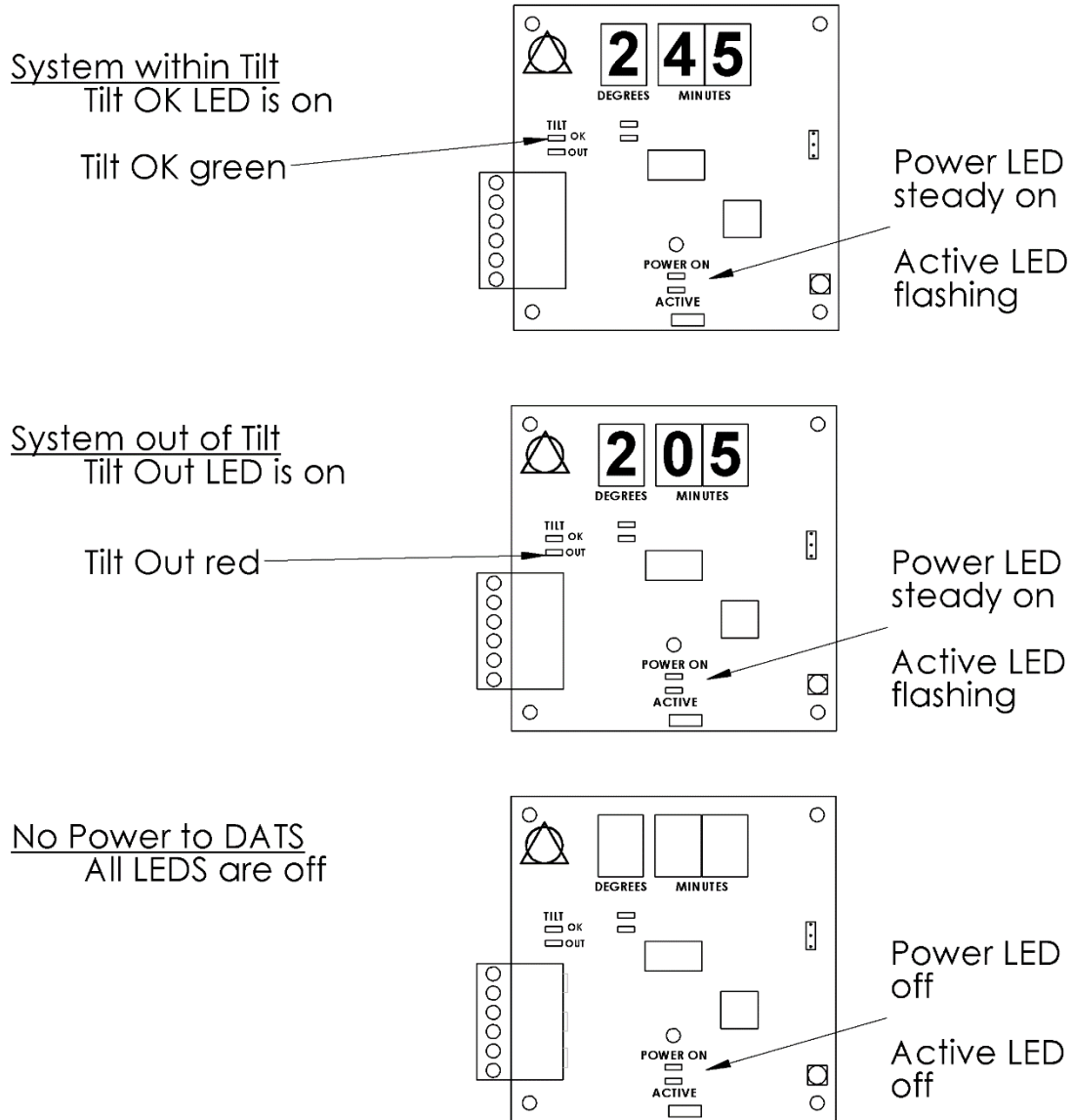

Figure 26: Digital Aiming Tilt Sensor LED Indicators

Table 2: Trouble Shooting Chart

Problem	Cause	Check	Corrective Action
All Lamps Out	No Power	Check “Board Power” LED, on printed circuit board	Restore power to the light unit
			Restore power to the printed circuit board
		Check voltage at terminal block, TB 1, across Common and Output 1 or Output 2. (less than 19.0V)	Restore power to the light unit
		Check voltage at CB 1. (240V)	
		Check that all wire leads to and from the 4 and 6 position terminal blocks are secure by gently tugging on the wire where it is crimped to the terminals. If any wire comes out of its crimped terminal, it needs replacement.	If any wires are disconnected from their crimped terminals, contact ALC for replacement parts.
	Check that all positions on all terminal blocks are closed.	Turn off power. With a screw driver, turn each screw clockwise at each terminal block position until they each have made contact with either a wire lead or the terminal block itself.	
	Out of Tilt	Check “Tilt OK” indicator on PCU printed circuit board	If off, re-aim light unit that is out of tilt.
		Check LED indicators on Digital Aiming Tilt Sensor	“Power” LED is off “Active” LED is off
Green “Tilt OK” is off Red “Tilt Out” is on			Re-Aim light unit
Lamps out	Check lamps	Turn power off, replace lamps, and turn power on.	
Single Lamp Out	Lamp out	Check lamp	Turn power off, replace lamp, and turn power on.
Premature Lamp Failure	Too much voltage	Check voltage going into light unit. (Maximum expected value 18.3VAC at TB1, across Common and Output 1 or Output 2)	Move the High Intensity tap to a lower value. Then recalibrate the PCU.
		Check voltage going into light unit. (Maximum expected value 15.9VAC at light unit terminal block)	

7.5 Replacement Parts

Table 3: Replacement Parts List

Part Number	Name	Manufacturer	MFG Part #	Rating / Physical Characteristics
59E	Frangible Coupling	ALC		
88-2A51	Strain Relief	Common Part		
88-2A55	½" Coupling	Common Part		Schedule 80 / PVC
106	PAPI Lamp	Osram	64339-A	105 Watt 6.6 Amp
88-3A15	4 Pos Terminal Block	Marathon		300V @ 20Amps
88-3A21	6 Pos Terminal Block	Marathon		300V @ 20Amps
88-3A35	Light Unit Cover	ALC		
88-3A43	3 Leg Mounting Frame	ALC		
88-3A44	4 Leg Mounting Frame	ALC		
88-4V61	2 Pos PCB Plug Out	Phoenix		300v @ 10 amps
88-4V64	3 Pos PCB Plug Out	Phoenix		300v @ 10 amps
88-6A40	Digital Aiming Tilt Sensor	ALC		
88-8A02	Leg Kit	ALC		
88-9A25	Liquidtight Straight Fitting ½"	Common Part		
88-9A31	Liquidtight Connector Disk	ALC		Aluminum
88-9A35	Liquidtight Flexible Nonmetallic Conduit	Common Part		Type LFNC-B
88-9A37	Light Unit Upper Cable	ALC		
88-9V36	VPAPI Lower Cable	ALC		

	Part Number	Part Name
1	88-4V50	Relay
2	88-4V45	8 Position Terminal Block (TB5)
3	88-4V75	VPAPI PCB
4	88-4V25	15A 2 Pole Surface Panel Break
5	88-4V56	PCU Interior NEMA Plate
6	88-4V32	350V GDT Surge Arrestor
7	88-4V33	Ground Lug
8	88-3A15	4 Position Terminal Block (TB4)
9	88-4V45	8 Position Terminal Block (TB3)
10	88-4V35	3 Position Terminal Block (TB1)
11	88-4V28	Lexan 3 Pos TB Mount
12	88-4V15	Transformer T1 2KVA
13	88-4V41	12 Pos Terminal Block (TB2)
14	88-4A29	Lexan 12 Pos TB Mount
15	88-4V21	Transformer T2 240/120 Volt

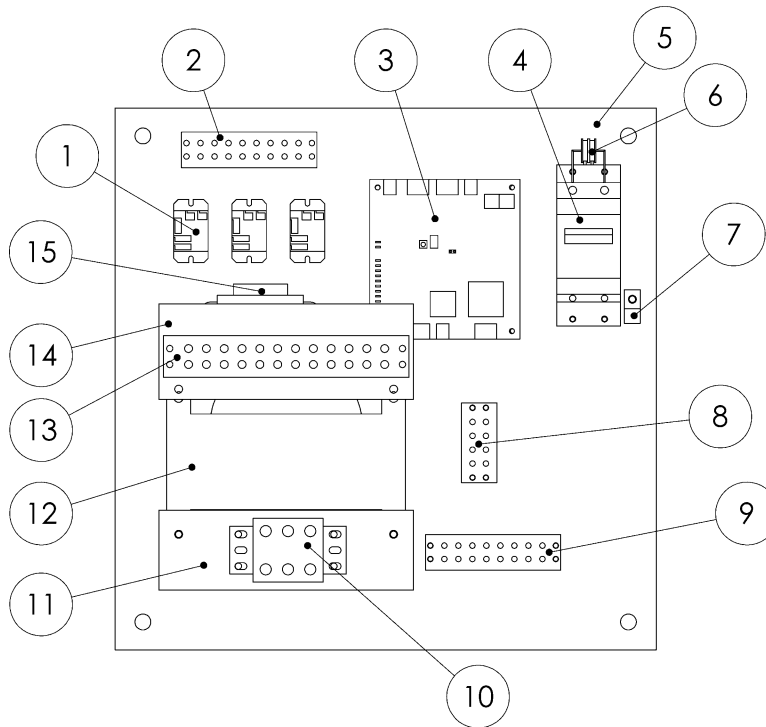

Figure 27: Power Control Unit Parts

	Part Number	Part Name
1	106	PAPI Lamp
2	88-6A40	Digital Aiming Tilt Sensor
3	88-3A21	6 Position Terminal Block
4	88-3A15	4 Position Terminal Block

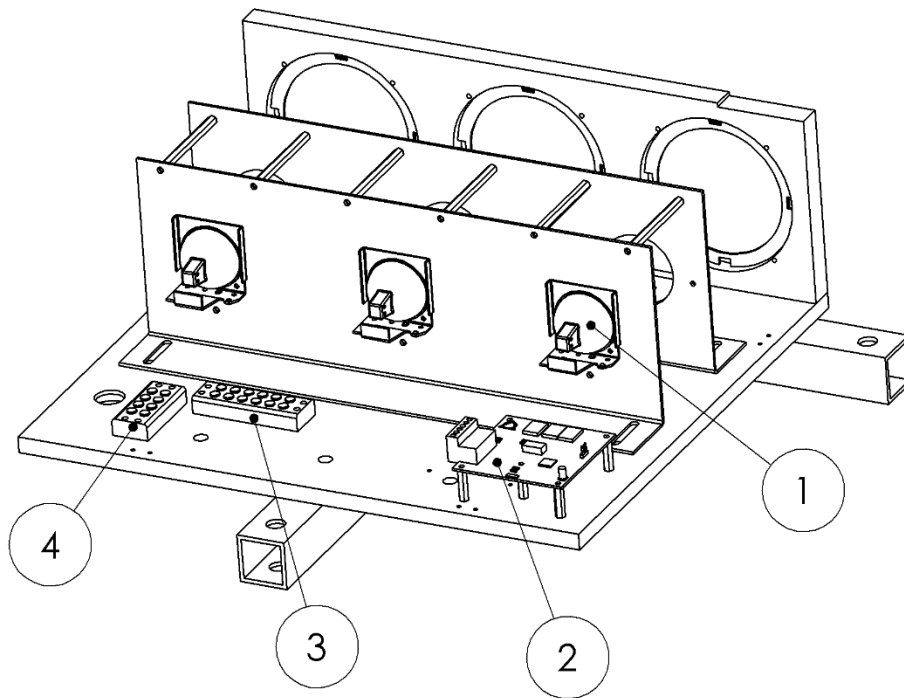

Figure 28: Parts VPAPI Light Unit

	Part Number	Part Name
1	88-3A35	Light Unit Cover
2	88-2A51	Strain Relief
3	88-2A55	½" PVC Coupling
4	88-9A25	Liquidtight Straight Fitting ½"
5	88-9A35	Liquidtight Flexible Nonmetallic Conduit
6	88-9A31	Liquidtight Connector Disk
7	59E	Frangible Coupling
8	72	Base Plate (purchased separately)

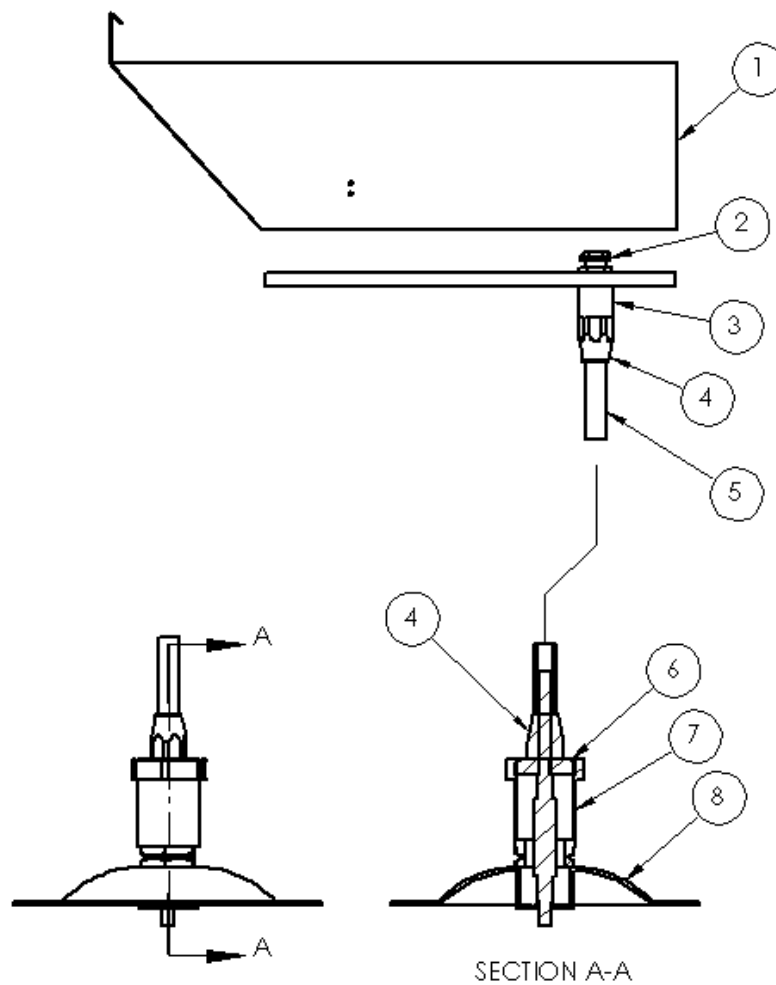

Figure 29: Parts External Fittings

	Part Number	Part Name
1	88-9A37	Light Unit Upper Cable
2	88-9V36	VPAPI Lower Cable

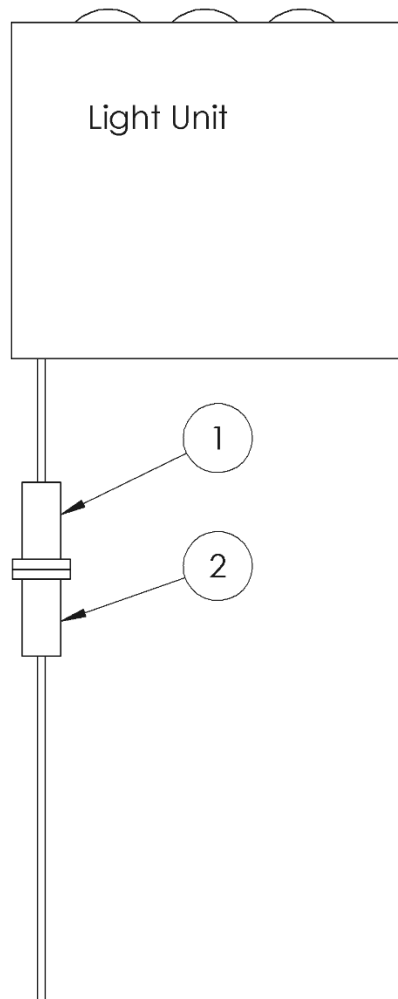

Figure 30: Parts, Wire Harnesses

	Part Number	Part Name
1	88-8A02	Leg Kit Assembly
2	88-3A43	3 Leg Light Unit Mount (standard)
3	88-3A44	4 Leg Light Unit Mount (optional)

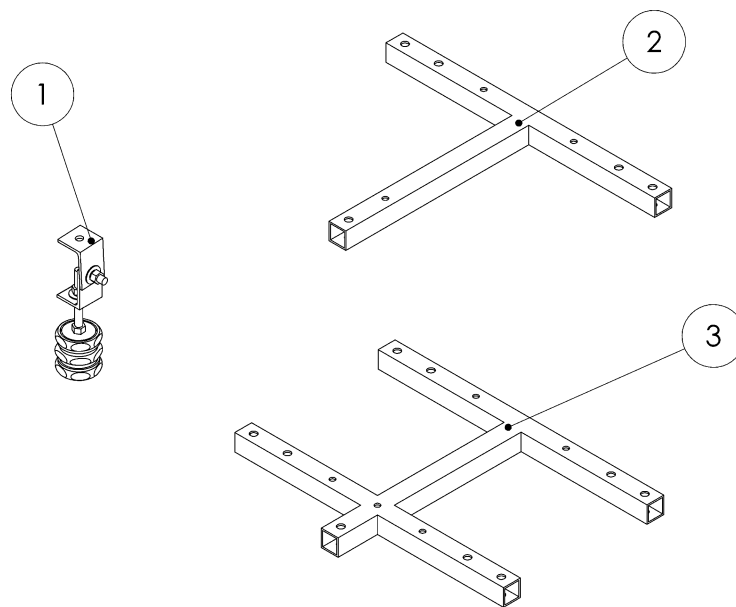

Figure 31: Mounting Hardware

Appendix

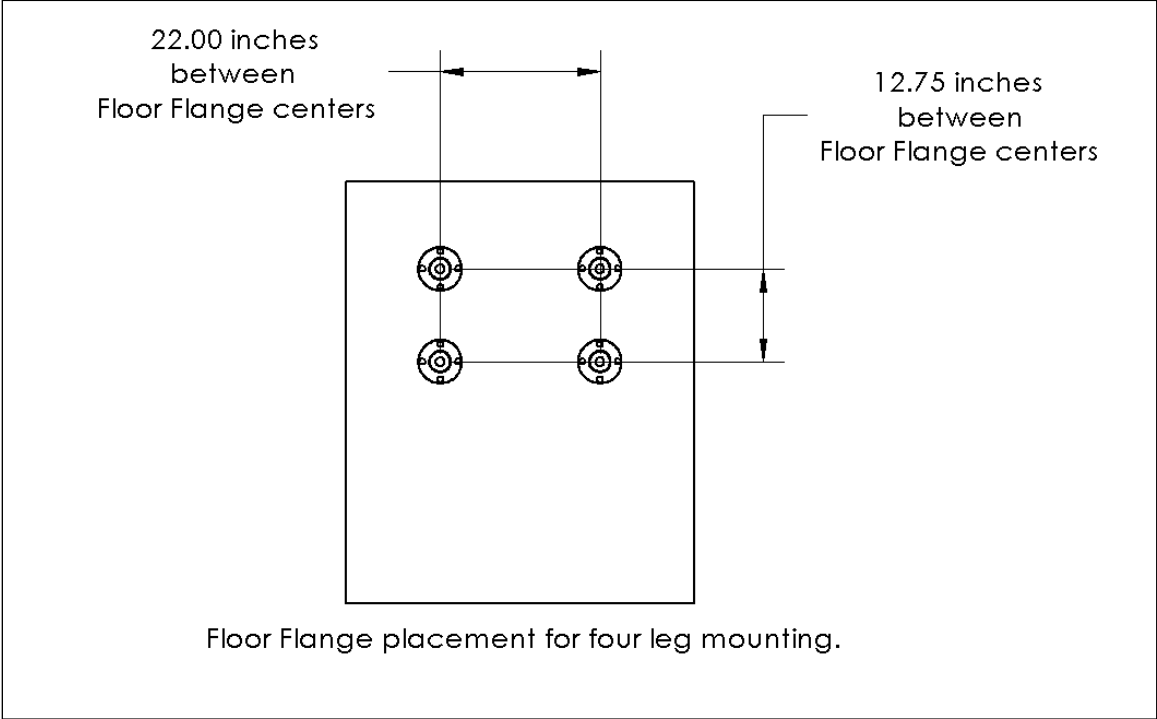

Figure 32: 4 Leg Floor Flange Placements