

Airport**Lighting**Company
An ISO 9001:2015 Certified Company

OWNER'S MANUAL



Type L-828, Type L-829
Ferroresonant Constant Current Regulator
FR TYPE





Airport**Lighting**Company

An ISO 9001:2015 Certified Company

Ferroresonant Constant Current Regulator Type L-828, Type L-829 FR TYPE Owner's Manual

ETL Certified to:
FAA AC 150/5345-10H



Manufactured by:

Airport Lighting Company

108 Fairgrounds Drive
Manlius, New York 13104
(315) 682-6460

Email: info@airportlightingcompany.com

Website: www.airportlightingcompany.com



How to Get Help	1
Warning	2
Warranty	3
General Information	4
Scope	4
Equipment Description	4
Environmental Requirements	5
Electrical Requirements	5
Control Capabilities	6
Theory of Operation	8
System Overview	8
Description of Main Components	9
Shipping & Sizing Information	13
Small Cabinet Dimensions	13
Large Cabinet Dimensions	14
Shipping & Sizing Information	15
Installing the CCR	16
Tools Required	16
Installation Precheck	16
Terminating CCR Connections	17
Turning the CCR On for the First Time	18
System Check in Local Mode	18
Installing the Remote Control	19
Remote Control with Ethernet/IP, ModTCP, RS485	22
Checking Current Output	22
Operating Instructions	23
How to Navigate the CCR Display and Keypad	23
The CCR Keypad	24
Understanding the Digital Control Monitoring Unit (DCMU) Display	26
CCR Configuration	28
Common CCR Configuration Changes	30

TABLE OF CONTENTS



Airport**Lighting**Company

An ISO 9001:2015 Certified Company

Options	32
IRMS / Megger	32
IRMS / Megger Options	34
Lamp Out	35
VA Changes	36
CC as Enable	37
Troubleshooting	39
Warnings, Alarms, and Faults	39
Warnings and Alarms	39
Warnings and Alarm Table	40
Faults	48
Fault Table	48
Troubleshooting	51
Troubleshooting Table	51
Restoring Known Good Settings	53
Completing In-Field Recalibrations	54
Maintenance	60
Preventative Maintenance	60
Monthly CCR PM Task List	60
Yearly CCR PM Taks List	60
Glossary of Terms	61
Wiring Diagram	62
Component Panel Layout Diagram	64
Small CCR Component Panel Layout Diagram	64
Large CCR Component Panel Layout Diagram	66
CCR Menu Navigation Flowchart	68
Replacement Parts	76
Addendum 1: IEC Monitoring	77



List of Figures

Figure 1: Ferroresonant Regulator Block Diagram	8
Figure 2: S1 Wiring Diagram.....	12
Figure 3: Small Cabinet Dimensions	13
Figure 4: Large Cabinet Dimensions.....	14
Figure 5: Output Surge Arrestor with cap	17
Figure 6: Output Surge Arrestor without cap	17
Figure 7: 120v Internally Powered Wiring Diagram	21
Figure 8: 120v Externally Powered Wiring Diagram	21
Figure 9: 24v Internally Powered Wiring Diagram.....	21
Figure 10: 24v Externally Powered Wiring Diagram	21
Figure 11: Keypad and Display of a 240V input CCR	23
Figure 12: The Configuration Menu.....	27
Figure 13: Block Flow of Menu Navigation	28
Figure 14: A Megger Measurement.....	32
Figure 15: The Megger Screen	33
Figure 16: Output Disabled Warning	38

List of Tables

Table 1: Standard Ratings (FAA)	4
Table 2: Fuses	11
Table 3: Shipping & Sizing Information	15
Table 4: CCR Output Currents.....	22
Table 5: Main Screen Information	26
Table 6: Warning and Alarm Codes	40
Table 7: Fault Table.....	48
Table 8: Troubleshooting Chart.....	51
Table 9: Replacement Parts.....	76



Have Questions? Contact Us:

 **GENERAL INQUIRY:** (315) 682-6460

 **EMAIL:** info@airportlightingcompany.com

 **TECHNICAL SUPPORT:** (866) 212-1060

 **EMAIL:** support@airportlightingcompany.com

 **WEBSITE:** www.airportlightingcompany.com

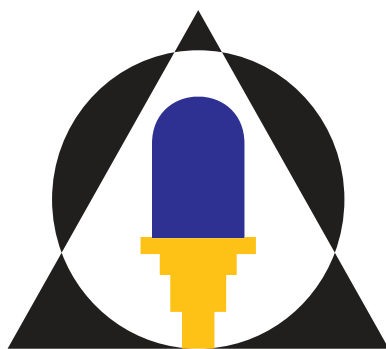

Airport**Lighting**Company

An ISO 9001:2015 Certified Company

**108 Fairgrounds Drive
Manlius, New York 13104**



WARNING



Airport Lighting Company

An ISO 9001:2015 Certified Company

Airfield circuits are designed to supply a constant current series output. To power numerous devices on a constant current series circuit, the constant current regulator (CCR) will produce a high voltage across the output.

Input Voltage Warning

The input voltage is listed on the CCR nameplate. Verify the input voltage on the nameplate before working on the CCR.

Input Current Warning

The input current of the CCR can be very high. A 30kW CCR can see an input current in excess of 165 amps. Verify the input current on the nameplate before working on the CCR.

Output Voltage Warning

The nominal output voltage of the CCR can be as high as 4,545V on a 30kW CCR ($30,000 / 6.6$), or even greater in open-circuit instances. Check the output voltage on the nameplate before working on the CCR. Never put a DMM (digital multimeter) on the output circuit to measure voltage. Doing so may cause DMM failure and/or risk of electrical shock. Consult *To Verify Output Voltage* for output voltage measurement instructions.

Output Current Warning

The output current of the CCR is dangerous. It is designed to work in a 6.6 Amp, or 20 Amp series circuit. Check the output current on the nameplate before working on the CCR. The CCR will shut down if there is an open circuit, but it will not turn off in a short circuit. Protective devices are designed to protect equipment, not to protect personnel.

Prior to installation or servicing

Follow all local and national electrical codes for installation and service of the CCR.

Only qualified service personnel should be allowed to install and service the CCR.

Open all sources of electricity to the CCR. Follow lock out / tag out procedures to ensure continued safety while completing work. Verify correctness of work done with a second set of eyes before re-energizing the CCR.



WARRANTY



Airport**Lighting**Company

An ISO 9001:2015 Certified Company

Airport Lighting Company guarantees that the equipment manufactured by Airport Lighting Company and covered by this manual has been manufactured to and will perform in accordance with application specifications. Any defect in design, materials or workmanship which may occur during proper and normal use during a period of one (1) year from date of installation or a maximum of two (2) years from date of shipment will be corrected by repair or replacement by Airport Lighting Company, with transportation costs borne by the purchaser. This guarantee covers the Ferroresonant Constant Current Regulator, L-828 and L829.

Scope

This instruction manual is provided for use with FAA type L-828 and L-829 Constant Current Regulator as covered by the current revision of FAA AC 150/5345-10 and manufactured by Airport Lighting Company, Manlius, NY, USA. It is for use with Ferroresonant Constant Current Regulators; FR Type.

Equipment Description

Ferroresonant Constant Current Regulator

Type

- L-828 Regulator without monitoring
- L-829 Regulator with monitoring

Classes

- Class 1 – 6.6 amperes (A) output current
- Class 2 – 20.0 A output current

Style

- Style 1 – three brightness steps
- Style 2 – five brightness steps

Standard Ratings (FAA)

Standard Sizes (kW out), Class 1 (6.6 amps)	1, 2, 4, 5, 7.5, 10, 15, 20, 25, 30
Standard Sizes (kW out), Class 2 (20 amps)	15, 20, 25, 30
Standard Input Voltages	208, 220, 240, 480
Frequency	60 Hz

Table 1: Standard Ratings (FAA)



Environmental Requirements

NEMA 1 rated. Indoor installation.

- All models are cooled by free convection.
- Operating temperature -40°C to +55°C.
- Operating RH: 10% to 95% Relative Humidity
- Operational Altitude 0 to 2,000m above sea level*
- Floor mountable.
- FAA Class A Conducted and Emitted Radiation

**Operational Altitude requirement is dictated by FAA Advisory Circular 150/5345-10. The FR CCR design has been proven in altitudes in excess of 2,000m and will operate in altitudes up to 3,000m.*

Electrical Requirements

Input Voltage and Current

All units are built and calibrated to the input voltage listed on nameplate. If the input voltage does not match the nameplate input voltage, please contact Airport Lighting Company for further instructions.

Control Capabilities

The regulator can be controlled by various means:

- The front panel keypad/display
- Remote-control connection to internal CCR terminal blocks with 24VDC, 48VDC, or 120VAC power
- Ethernet/CAT5 via configured PLC on ModTCP or Ethernet/IP*
- RS485 ModbusRTU via configured PLC*
- RS232 serial connection to computer

** feature requires additional hardware ordered by COMM Options*

Front Panel Display Control

The front panel display is the primary method of entering the CCR settings and operating the CCR in Local mode. Local mode operation allows the user to control the CCR with the press of a button, independent of calls from a remote system. This can be used for setup, diagnosis of airfield circuit problems, or troubleshooting. For more information about navigation of the CCR with the display, see *How to Navigate the CCR Display and Keypad*.

Remote Control

Remote control is available through the DIN rail mounted terminal block connections inside the regulator. The remote-control connection will utilize wire connections that include B1 through B5 or B10 through B100. The Airport Lighting Company CCR provides multiple field-changeable control supply voltage solutions. The remote-control inputs for the CCR can be powered internally by the regulator or externally as part of the remote system. For more information, see *Installing the Remote Control*.

Ethernet

Ethernet connectivity requires a Communications Card to be installed in the Digital Control & Monitoring Unit (DCMU) upon ordering the CCR. Ethernet can be used to communicate with configured PLCs via Ethernet/IP interface or ModTCP (Modbus TCP).

RS485 Serial Connection

RS485 serial connectivity requires a Communications Card to be installed on the Digital Control & Monitoring Unit upon ordering the CCR. The RS485 connection allows for communication using ModbusRTU.



RS232 Serial Connection

The CCR allows for RS232 serial connection to be made at the DCMU. Each DCMU comes with a RS232 header that is used to connect directly to a PC using the DCMU Configurator software. This connection is used primarily in factory setup and calibration of the CCR.



The Ferroresonant Constant Current Regulator (CCR) is designed to convert grid, single phase, AC power to constant-current series loop power. For FAA installations, the input is typically 208, 220, 240 or 480 Volts AC, 60Hz. The output is digitally controlled to maintain a constant current. The ferroresonant regulator design produces a sine wave current output. It does this by using a ferroresonant transformer, capacitor bank and a solid-state relay (SSR) to control the output current. The ferroresonant transformer drives the output power of the CCR. When the SSR is open the capacitor bank will inject power into the circuit. If the SSR is closed or shorted, power is diverted from the circuit. The ferroresonant transformer and capacitor bank, along with the digitally-controlled SSR, produce the expected output current with an AC sinusoidal waveform.

System Overview

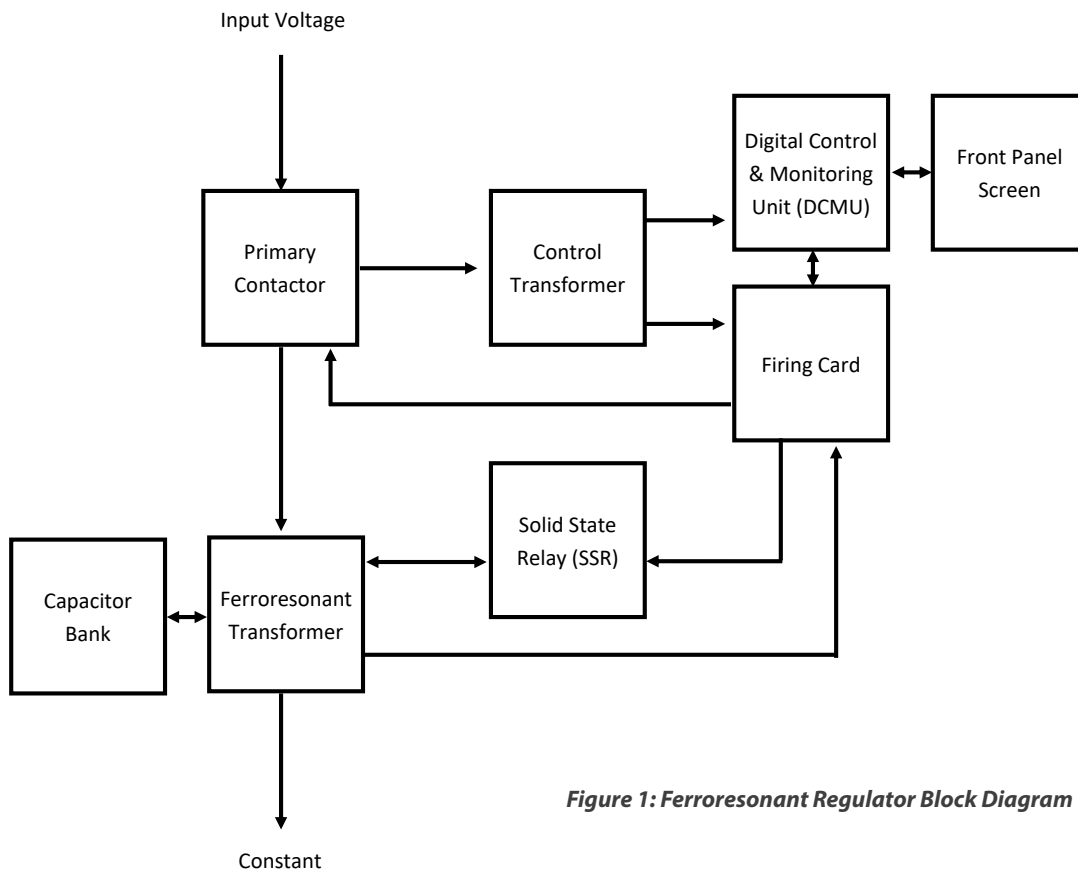

Figure 1: Ferroresonant Regulator Block Diagram



Figure 1 is a block diagram of the ferroresonant system. The AC Input connects to the contactor and control transformer in parallel. The control transformer has both 120VAC and 15VAC outputs. The 15V output is used to power the Digital Control & Monitoring Unit (DCMU) and the Firing Card. The DCMU is the electronic logic center of the system. It communicates with the firing card and display. The 120V is used to power the contactor coil and may be used to power the remote control. The firing card receives measurements from the ferroresonant transformer, current transformer (CT) on the output winding, and CT on the input wiring if equipped. The firing card turns the contactor on and off, when the system is engaged or disengaged. The firing card also signals the SSR to close for some duration on every AC-power half-cycle to control the output of the ferroresonant transformer. The capacitor bank in combination with the ferroresonant transformer produces the sinusoidal constant current output.

Description of Main Components

Ferroresonant Transformer

The ferroresonant transformer is the large transformer mounted in the lower section of the cabinet. The ferroresonant transformer receives the incoming power from the contactor and delivers constant current power to the airfield. There are multiple windings on the ferroresonant transformer. The capacitor windings are connected to the capacitor bank. Voltage sense and capacitor sense winding provide feedback information to the firing card and DCMU. The inductor windings are connected to the SSR and are used to control the output current.

Input Contactor

The contactor is sized to the input current. The input side of the contactor is in parallel with the control circuit primary-side fuse block. When the power is turned on at the keypad or by remote control, the contactor is activated by the firing card. When the contactor coil is on, the airfield current is on.

Solid State Relay

The solid-state relay, SSR, is used to adjust the output current. The firing card decides when and how long the SSR needs to engage the capacitor bank. The SSR is engaged during every half cycle.

Firing Card

The firing card is the interface between the ferroresonant transformer and the Digital Control & Monitoring Unit (DCMU). The firing card turns on the contactor, engages the SSR, and reads the ferroresonant transformer voltage, the capacitor voltage, the output current and the input current (optional).



Input Surge Arrestor

The input surge arrestor is used to protect the control circuit from large input voltage spikes.

Output Surge Arrestors

The output surge arrestors are on the output circuit to protect the ferroresonant transformer from high voltage spikes and lightning.

Control Transformer

The control transformer is mounted on the control panel. The input to the control transformer is in parallel with the input of the contactor. When power is supplied to the CCR the control transformer always has power. The settings for the control transformer are determined by the input voltage. For typical FAA installations, there are 4 possible settings for the expected input voltage: 208, 220, 240, and 480. There are 2 output windings on the transformer; 15 VAC for the electronic control circuit, and 120VAC for the contactor coil power. 120VAC is also available to power the remote control, if desired.

The control transformer is configured at the factory for the specified input voltage. The control transformer will output between 120-130 VAC across 9 and 10, and 15-16.5 VAC across 11 and 12 when it is configured properly and when is operating at nominal voltage.

Current Transformers

Standard on all CCRs is an output current transformer (CT). One output wire of the ferroresonant transformer loops nine (9) times through the CT on Class 1 (6.6 amp) CCRs, and three (3) times through on a Class 2 (20 amp) CCR. The CT leads connect to the firing card and provide the output current measurement to the DCMU. An optional input CT is available to provide the DCMU with the input current measurement. By having the input current measurement, the CCR can measure the input current and calculate the kW in, kVA in, and the CCR Power Factor.



Fuses

The CCR comes standard with five (5) fuses installed. There is a pair of fuses on the input voltage lines that run to the primary side of the control transformer. Each secondary winding of the control transformer is also fused, through DIN rail mounted fuse blocks.

F1 and F2 fuses are on in a panel-mounted fuse holder. They fuse the primary side of the control transformer.

F3 is a fuse on the 15V secondary winding of the control transformer. It is in a DIN rail mounted fuse block. This fuse is for the DCMU power circuit.

F4 is a fuse on the 120V secondary winding of the control transformer. It is in a DIN rail mounted fuse block. This fuse is for the contactor coil power circuit only.

F5 is a fuse on the 120V secondary winding of the control transformer. It is in a DIN rail mounted fuse block. This fuse is for a 120V Internally powered remote circuit only. Since the remote control voltage is field-changeable, the fuse block will still be installed even if the CCR is ordered in a non-120V Internal configuration, and the fuse will still be shipped with the CCR.

Fuse	Characteristics	ALC Part Numbers
F1, F2	5A Fast-Acting, 10 mm x 38 mm, 250V Midget Fuse	82-88
F3	5A Fast-Acting 1/4 x 1 1/4, 250V, Glass 3AG Fuse	82-76
F4	2.5A Fast-Acting, 1/4 x 1 1/4, 250V, Glass 3AG Fuse	82-77
F5	1A Fast-Acting, 1/4 x 1 1/4, 250V, Glass 3AG Fuse	82-78

Table 2: Fuses



S-1 Cutout (Optional)

DO NOT REMOVE AN S-1 HANDLE WHILE POWER IS ON
POWER MAY STILL BE PRESENT IN THE CCR EVEN WITH AN S-1 HANDLE OUT
S-1 HANDLE REMOVAL IS NOT A SUBSTITUTE FOR LOCK OUT / TAG OUT PROCEDURES

The Airport Lighting Company S-1 Cutout is a safety device that is used to disconnect the field circuit from the CCR. There are two (2) "positions" for an Airport Lighting Company S-1 to be in; the handle will either be in or out.

When the handle is in, the field circuit is connected to the CCR, and the field circuit will have power.

When the handle is out, the CCR output will short. Since the CCR will operate in a short this can be helpful for troubleshooting. This also means that the CCR may still have power in the enclosure, even if the S-1 handle removed. The field circuit will also short, allowing for continuity in the series circuit.

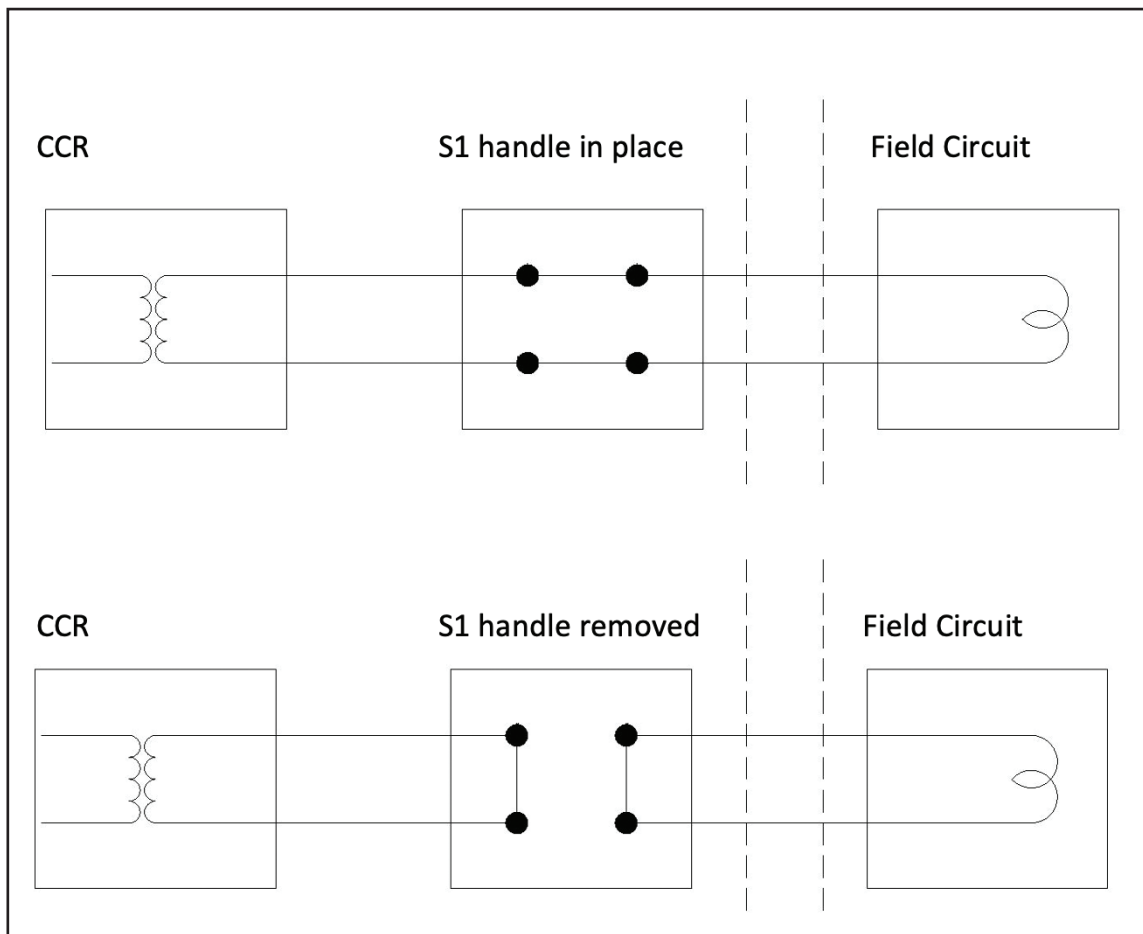

Figure 2: S1 Wiring Diagram

Shipping & Sizing Information

Small Cabinet Dimensions

CCRs with kW outputs that range from 1kW to 10kW are installed in enclosures as shown:

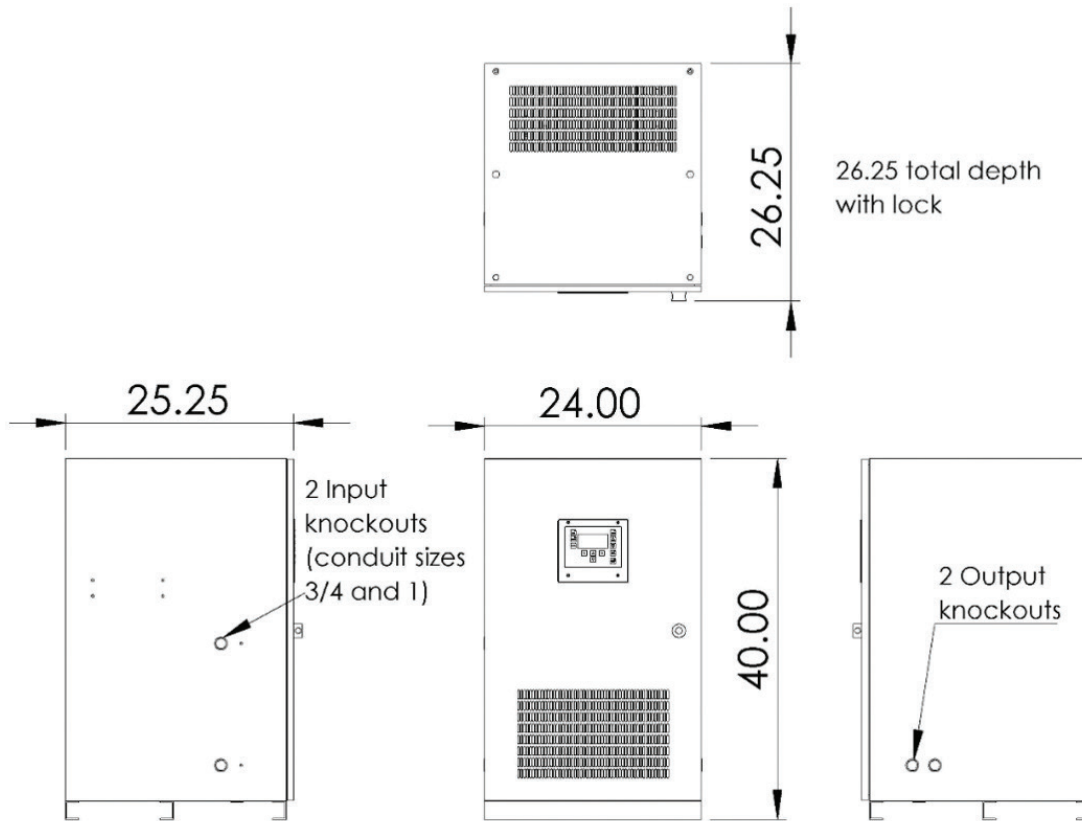

Figure 3: Small Cabinet Dimensions

Large Cabinet Dimensions

CCRs with kW outputs that range from 15kW to 30kW are installed in enclosures as shown:

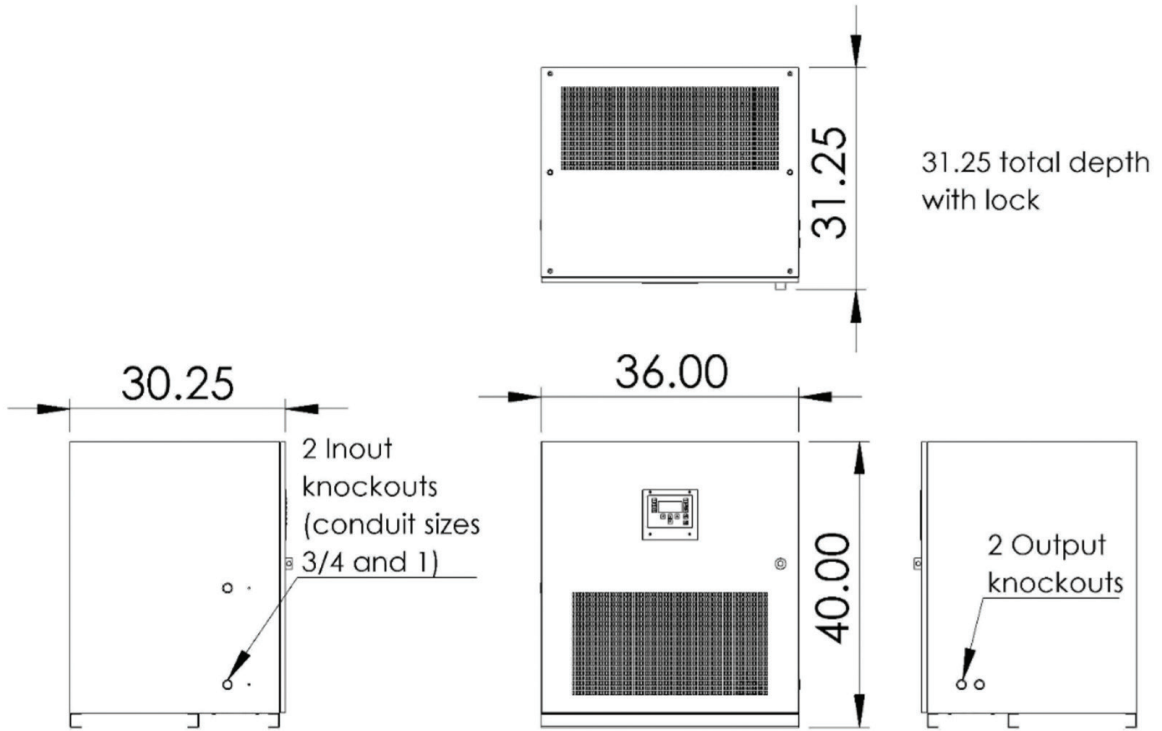

Figure 4: Large Cabinet Dimensions



Shipping & Sizing Information

kW Rating	CCR Ship Weight <i>(No Options)</i>	Shipping Size <i>(With Pallet)</i>	CCR Install Weight <i>(No Options)</i>	Install Size <i>(Without Pallet)</i>
1	300	30" W x 31" D x 46" H	280	24" W x 25.25" D x 40" H
2	350	30" W x 31" D x 46" H	330	24" W x 25.25" D x 40" H
4	400	30" W x 31" D x 46" H	380	24" W x 25.25" D x 40" H
5	450	30" W x 31" D x 46" H	420	24" W x 25.25" D x 40" H
7.5	530	30" W x 31" D x 46" H	510	24" W x 25.25" D x 40" H
10	630	30" W x 31" D x 46" H	610	24" W x 25.25" D x 40" H
15	865	40" W x 36" D x 46" H	835	36" W x 31.25" D x 40" H
20	1100	40" W x 36" D x 46" H	1070	36" W x 31.25" D x 40" H
25	1300	40" W x 36" D x 46" H	1270	36" W x 31.25" D x 40" H
30	1450	40" W x 36" D x 46" H	1420	36" W x 31.25" D x 40" H

Table 3: Shipping & Sizing Information

Installing the CCR

Tools Required

- True RMS Digital Multimeter (DMM) with:
 - Voltage probes
 - Current clamp
- Basic Tools:
 - SAE wrenches, including a 9/16" wrench for output connection
 - Screwdrivers, including a 3mm or SAE equivalent slotted for terminal block connections
 - For ground lug connection:
 - 1/4" slotted screwdriver for CCRs of kW sizes from 1kW to 15kW
 - 3/16" hex bit, Allen wrench, or t-handle for CCRs of kW sizes from 20kW to 30kW
 - Hammer, adjustable pliers, etc. for removing knockouts and installing appropriate fittings
 - For incoming power connections:
 - Slotted (flathead) screwdriver
 - A 4mm Allen key is included with CCRs of kW sizes from 15kW to 25kW for incoming power connections. A 4mm hex bit or t-handle may be preferred in field.
 - For 30kW CCRs, a 5/16" hex bit or Allen wrench / t-handle for incoming power connections is required

Installation Precheck

- Unpack the CCR and inspect for shipping damage.
- Check the CCR nameplate.
 - Verify that the input voltage listed on the nameplate matches source voltage.
 - Verify that the kW output is correct.
 - Verify that the current output is correct (6.6A or 20A).

If the nameplate information does not match the site requirements, STOP INSTALLATION and contact Airport Lighting Company.

- Verify that the input wiring and all appropriate disconnects are properly sized to the load. If site-specific sizing calculations have not been made, refer to FAA Advisory Circular 150/5340-30 Design and Installation Details for Airport Visual Aids, current revision, Chapter 13 Power Distribution and Control Systems.
- Using the dimensions in *Small Cabinet Dimensions* and *Large Cabinet Dimensions*, verify the installation footprint is adequate.
- Position the included ground lug in the preferred orientation. Your CCR has two (2) threaded holes that provide flexibility during installation. The ground lug and brass ground screw are installed inside the CCR in factory to prevent damage during shipping.

Terminating CCR Connections

Follow all necessary lock out / tag out procedures.

Open the CCR supply circuit and lock out during installation.

- Once you have completed the *Installation Precheck* and installed all required fittings, position the CCR into its final location.
- Connect a ground to the CCR using the included lug.
- Connect L1 & L2 from the supply breaker directly to the contactor in the top left corner of the CCR panel. The panel has Input stickers designating this location.
 - If the CCR has Input Power Monitoring installed, run one of the supply legs through the current transformer on the left side of the enclosure. Do not loop the supply leg through the CT multiple times.
- The output connections must be made on the output surge arrestors, positioned on the bottom floor of the CCR. The surge arrestors are marked with Output stickers.
 - If the CCR has an Internal S-1 Cutout Installed, the output connections will be made directly in the S-1. Remove the S-1 handle and connect to the available lugs. The bottom edge of the installed S-1 has an Output sticker to designate this location.



Figure 5: Output Surge Arrestor with cap

Output surge arrester with protective cap installed.



Figure 6: Output Surge Arrestor without cap

Output surge arrester with cap removed. The 3/8" stud sticking up is the output connection point. Square washers are provided for connections that are made with non-terminated wire.



- Once output connections are made, connect remote wiring if applicable. Refer to *Installing the Remote Control* for additional information.
- Once all connections have been made, it is recommended to complete the initial start-up with the output shorted. This will ensure high-voltage protection of the field circuit while device operation is validated. Connect a wire, 12AWG or larger, between the output connections in the CCR.
 - If your airfield circuit has an Airport Lighting Company S-1 installed, removing the handle will short the CCR output circuit.
- **It is recommended to complete both *Turning the CCR on for the First Time* and *System Check in Local Mode*, even if you will be installing a remote control connection to the CCR.**

Turning the CCR on for the First Time

Use all required personal protection equipment while completing work on or around live circuits. Exercise caution at all times.

- Open the three (3) DIN rail-mounted fuse holders labeled FA3, FA4, and FA5.
- Turn on the power to the CCR at the supply disconnect.
- Using a digital multimeter (DMM), verify the input voltage. Due to natural occurrences, measured voltage may not exactly match anticipated voltage. The measured voltage should match the nameplate-rated voltage for the CCR within 5%.
- Using a DMM, check the output voltage of the CCR Control Transformer:
 - The voltage across terminals 9 and 10 is expected to be between 115V and 130V.
 - The voltage across terminals 11 and 12 is expected to be between 14.5V and 16.5V.
- If the measured voltage of either control transformer winding does not match the anticipated voltage, disconnect power to the CCR and contact Airport Lighting Company.
- Once your control transformer output voltages are verified, disconnect power to the CCR. Once power is disconnected, close the DIN rail-mounted fuse blocks – FA3, FA4, and FA5.

System Check in Local Mode

Complete the section even if you have connected a remote control.

- Before operating the CCR, review *How to Navigate the CCR Display and Keypad* for information about the user interface.
- Turn on CCR supply power.
- The CCR display screen will turn on and show you the main screen. Reference *Table 4: Main Screen Information* for a list of all information displayed.



- Place a current clamp on an output wire and connect the clamp to a DMM. Using the LOCAL UP and LOCAL DOWN buttons, increment through each brightness step and verify the current output. Use *Table 4* for current references of each step.
- Once the current measurements are verified, push the OFF button once to turn the CCR output off. Disconnect power to the CCR and remove the output shorting wire that was installed, or reinsert the S-1 handle if equipped.
- The CCR is now ready for operation in Local mode. If your installation requires a remote control connection, continue to *Installing the Remote Control*.

Installing the Remote Control

The Airport Lighting Company CCR has multiple remote control configuration options. While the CCR can be ordered to match an existing control system, it is recommended to verify that the installed options will accommodate the control system.

- The first step to connecting and testing operation is to verify the operation voltage of the remote control system. The remote control system will most commonly operate on 24VDC or 120VAC signals.
- Once the nominal control system voltage is determined, verify the source of power for the system. The control system will either supply its own voltage (referred to as “Externally Powered”) or it will use a voltage supply from the CCR (referred to as “Internally Powered”).
- Once you have determined the voltage level and source, you can begin wire terminations:
 - Disconnect the CCR supply power.
 - Connect B10 thru B100 or B1 thru B5 to the matching labeled terminal blocks. *Note: The terminal blocks for B10 thru B100 are shared with B1 thru B3.*
 - If your existing control system has both CC and B1 wires, remove the jumper between the CC and B1 terminal blocks. Otherwise, leave the jumper in.

Wiring diagrams for the following steps are located at the end of this section.

- For 120v Internally Powered systems (*Figure 7*):
 - Connect the control system power wire to the CCI terminal block.
- For 120v Externally Powered systems (*Figure 8*):
 - Remove the 1A fuse from FA5.
 - Remove the white wire jumper between the bottom of terminal blocks 120N and N. The wire is labeled 120-INT.
 - Store both the 120-INT and 1A fuse for potential future use.
 - Connect the control system neutral wire to the N terminal block.



- For 24v Internally Powered systems (*Figure 9*):
 - Remove the 1A fuse from FA5.
 - Remove the white wire jumper between the bottom of terminal blocks 120N and N. The wire is labeled 120-INT.
 - Store the 1A fuse for potential future use.
 - Connect the 120-INT jumper between the N and 24N terminal blocks.
 - Connect the control system power wire to the +24V terminal block.
- For 24v Externally Powered systems (*Figure 10*):
 - Remove the 1A fuse from FA5.
 - Remove the white wire jumper between the bottom of terminal blocks 120N and N. The wire is labeled 120-INT.
 - Store both the 120-INT and 1A fuse for potential future use.
 - Connect the control system neutral wire to the N terminal block.

In all connection scenarios, it is recommended to verify that the CCR is set up to receive the correct signal voltage. Familiarize yourself with *Navigating Menus* before re-energizing the CCR.

- Once you have re-energized the CCR, make sure it is operating in Local mode. Line 1 of the CCR main screen will say Local, and the LED on the REMOTE button will not be illuminated.
 - Push the CONFIG button and enter the configuration menu password of 9999. Press the left DOT to enter.
 - With the cursor on CCR Config, press the left DOT to enter.
 - Scroll down to Parallel Inputs and press the left DOT to enter. *Note: the command is called Enable for this option.*
 - Ensure the cursor is on Enable, press the left DOT to enter.
 - Scroll down to Input Voltage, press the left DOT to enter.
 - This menu gives you the option of selecting 24V or 120V. Move the cursor up or down to select the voltage that matches the control system. Once it is selected with the cursor, press the left DOT button to save your choice.
 - You will be returned to the previous menu. Press the right DOT button to exit the configuration menus level-by-level.
 - Before being returned to the CCR main screen, you will be asked to record the changes you made. Press the left DOT button to save the CCR settings.

Your CCR is now wired and set up for remote control system use. To verify CCR operation with the control system, put the CCR into Remote mode by pressing the REMOTE button. Activate the control system at each step, B10 thru B100 or B1 thru B5. If problems arise, refer to *Troubleshooting*.



120 VAC Internal

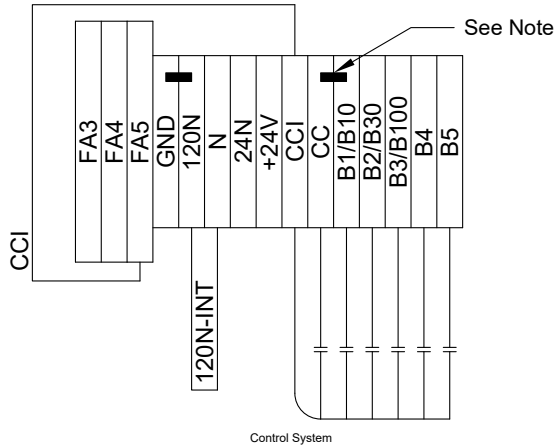

Note:
Remove jumper between B1/B10 and CC if separate B1 signal is provided by the control system.

Figure 7: 120v Internally Powered Wiring Diagram

120 VAC External

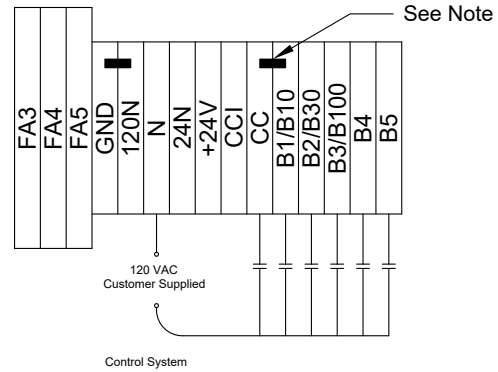

Note:
Remove jumper between B1/B10 and CC if separate B1 signal is provided by the control system.

Figure 8: 120v Externally Powered Wiring Diagram

24 VDC Internal

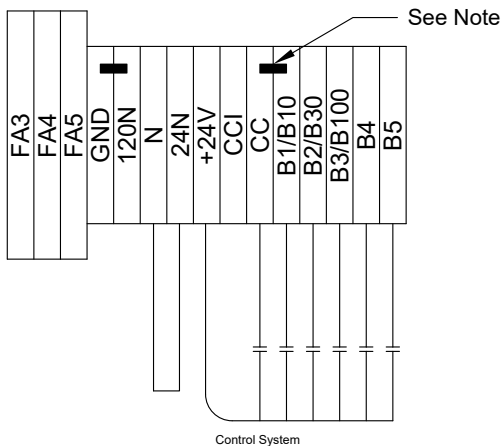

Note:
Remove jumper between B1/B10 and CC if separate B1 signal is provided by the control system.

Figure 9: 24v Internally Powered Wiring Diagram

24 VDC External

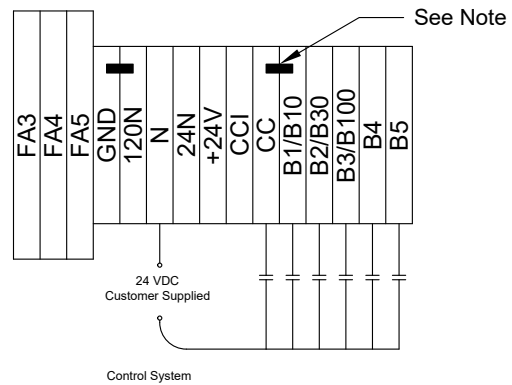

Note:
Remove jumper between B1/B10 and CC if separate B1 signal is provided by the control system.

Figure 10: 24v Externally Powered Wiring Diagram



Remote Control with Ethernet/IP, ModTCP, RS485

Connection to a remote control system, such as an ALCMS, utilizing Ethernet/IP, ModTCP, or RS485 requires a properly equipped Digital Control & Monitoring Unit (DCMU). Contact Airport Lighting Company for information about setup and wiring terminations for Ethernet/IP, ModTCP, and RS485 communication connections.

Checking Current Output

The following tables are a direct reference to FAA AC 150/5345-10 Section 3.3.1.1, Table 1. Once your CCR is installed, set up, and operational per Sections 5.1 through 5.5, you may choose to verify the measured, in-field current with a digital multimeter (DMM) and current clamp.

Maximum Output Current	Total Step Count	Step	Nominal Output Current	Allowable Current Range	Measured Current	Displayed Current
6.6	3	B10	4.8	4.7 - 4.9		
		B30	5.5	5.4 - 5.6		
		B100	6.6	6.5 - 6.7		
6.6	5	B1	2.8	2.7 - 2.9		
		B2	3.4	3.3 - 3.5		
		B3	4.1	4.0 - 4.2		
		B4	5.2	5.1 - 5.3		
		B5	6.6	6.5 - 6.7		
20	5	B1	8.5	8.2 - 8.8		
		B2	10.3	10.0 - 10.6		
		B3	12.4	12.1 - 12.7		
		B4	15.8	15.5 - 16.1		
		B5	20.0	19.7 - 20.3		

Table 4: CCR Output Currents



How to Navigate the CCR Display and Keypad



Figure 11: Keypad and Display of a 240V input CCR

The CCR display will show 4 lines of information at any given time. The display communicates directly with the DCMU inside the panel. The information on the screen can be scrolled through and will cycle around as if on a rolling drum.

Figure 11 shows the main screen of the CCR; this is the first screen that will come up when the CCR is powered on. Refer to *Understanding the Digital Control & Monitoring Unit (DCMU) Display* for additional information.



The CCR Keypad



The OFF button will turn the CCR off from any brightness step in Local or Remote.



The ON button will turn the CCR on to the most previous brightness step. There is an LED on the button that will illuminate when the CCR is on.



The LOCAL UP and LOCAL DOWN buttons change the brightness step of the CCR when it is in Local mode. If LOCAL DOWN is pressed when the CCR is at Step B10 (3 step configuration) or B1 (5 step configuration), the CCR will turn off.

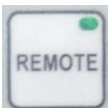

The REMOTE button engages or disengages the Remote Control option of the CCR. The LED in the button will illuminate if Remote is enabled. Pressing the button while already in remote will put the CCR back into Local mode.



The FAULT button has a red LED that will illuminate when a fault condition occurs. If a fault occurs, the CCR will turn off and the fault description will be displayed on the screen. Pressing the FAULT button will clear the fault code and force the CCR to attempt operation again. **DO NOT** continue to press the fault button to reset the CCR if the actual fault condition is not fixed. Doing so may cause damage to the CCR. See *Faults* for information about faults and how to remediate them.



The WARNING button has a yellow LED that will illuminate when a warning condition occurs. Pressing the WARNING button will cycle through any concurrent warnings. The CCR will still operate even if there are warnings. It is recommended to identify the cause of the warning and fix them as prolonged runtime with warning conditions may cause damage to the CCR. See *Warnings and Alarms* for information about warnings and alarms, and how to remediate them.



The CONFIG button is used to access multiple screens and menus. If equipped, pressing the CONFIG button once will access the “Megger Now” function. To access the configuration menu, press the CONFIG button again.

If IRMS/Megger functionality is not installed, pressing the CONFIG button once will access the configuration menu of the DCMU. See *CCR Configuration* for more information.

Pressing the CONFIG button again will show the diagnostics menu, which among other information stores the most recent faults and warnings. See *Accessing Diagnostics Menu* for more information.



The UP and DOWN buttons are the buttons that navigate the screen. If on the main screen, the information will cycle through as if on a rolling drum. If navigating the menus, you will see an arrow-cursor on the left side of the screen. The UP and DOWN arrows control the cursor.



The DOT buttons are selector buttons. If applicable, a command will be displayed above the DOT buttons. For example, when navigating the configuration menu, the left DOT button has the word “Enter” above it and the right DOT button has the word “Exit” above it. Pressing the corresponding button will execute the command.



Understanding the Digital Control Monitoring Unit (DCMU) Display

As stated in this section, the CCR display is controlled by pushing the UP, DOWN, and DOT buttons that are located below the screen. Each screen that is displayed will scroll continuously, as if on a rolling drum. Once you attempt to navigate past the last line of information, you will be returned to the first line.

The Main Screen

The main screen of the display shows the most important, at-a-glance information. The following table shows all the available information on the main screen:

Current Brightness Step & Local or Remote Indication	
<i>Note: This line will not scroll</i>	
Vin – Input (Source) Voltage Measurement	Iin – Input Current Measurement, if equipped. If not equipped, this line will show: "Iin=-----"
Vout – The voltage reading of the connected field output circuit	Iout – The current reading of the connected field output circuit
kVAo – The kVA calculation of the connected field output circuit	kWo – the kW calculation of the connected field output circuit
*kVAi – The kVA calculation of the supply	*kWi – The kW calculation of the supply
*PFIn – Power factor calculation of the supply	*PFOut – Power factor calculation of the output
Lamps Out – Current count of lamps out, must be configured, enabled, and calibrated. If not equipped, this line will show: "Lamps Out=---"	Hz – The configured AC voltage frequency
Temperature – Displays the current temperature reading at the DCMU in centigrade	Mgr – Displays the current megger reading (if equipped). Until a megger test is run, this line will show: "Mgr=?????"
HwVer – Hardware version of the DCMU	SwVr – Software version of the DCMU

Table 5: Main Screen Information

Note: The kVAi, kWi, PFIn, and PFOut options only appear on the screen if the CCR is equipped with an input CT.



Navigating Menus

The menus of the CCR are set up as a collection of folders within folders, similar to a file cabinet. By using the UP, DOWN, and DOT buttons, it is possible to scroll through folder selections, and open a folder with its own options and sub-folders.



Figure 12: The Configuration Menu

Figure 12 shows the main configuration menu. While navigating the menus the top line, in this case “Config”, and the bottom line, in this case “Enter” and “Exit”, will not scroll upon pressing the UP or DOWN buttons.

Above each DOT button, on the fourth line, are commands that can be executed by the corresponding DOT button.

As you can see, the second and third lines have arrows. The ↓ (down arrow) on the third line is showing you that there are additional options to look at. Pressing the DOWN button will scroll through the options.

The → (right arrow) is a cursor for the menu. Upon scrolling up or down, the option next to the → cursor will change. When you have reached the menu you’d like to open, use the Enter button to navigate to the next sub-folder.



CCR Configuration

The Airport Lighting Company CCR has multiple field-configurable options. While these options may be changed during initial setup, generally with the advice of an Airport Lighting Company representative or with the help of this manual, the day-to-day use of the configuration menu is not anticipated.

Review *How to Navigate the CCR Display and Keypad*, *The CCR Keypad*, and *Understanding the Digital Control Monitoring Unit (DCMU)* before continuing.

As stated in *Navigating Menus*, the CCR configuration menu is set up in a “nested folder” setup, like a file cabinet or the files on your computer. To understand the method of navigating referenced in this manual, see the below example of a block flow diagram that navigates to the option for brightness step count:

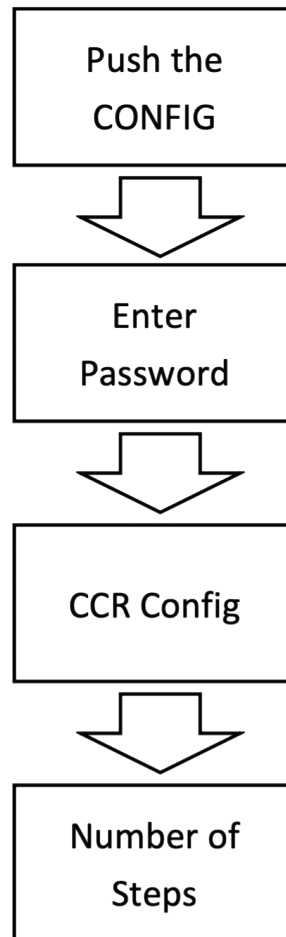

Figure 13: Block Flow of Menu Navigation



The "plain text" designation to describe the navigation shown in Figure 13 is:

Push the CONFIG button > Enter Password > CCR Config > Number of Steps

This manual will reference the plain text navigation style. For subsequent menu references in this manual, the steps "Push the CONFIG button" and "Enter Password" will be omitted.

Accessing the Configuration Menu (IRMS / Megger not installed)

- From the CCR main screen, press the CONFIG button once.
- You will be prompted for a password. The password on all Airport Lighting Company CCRs is "9999". Use the UP and DOWN buttons to change the number above the ↑ up arrow cursor. Press the right DOT button to advance to the next digit. Once the password is entered, push the left DOT button to advance to the menu.

Accessing the Configuration Menu (IRMS / Megger installed)

- From the CCR main screen, press the CONFIG button once.
- With the IRMS / Megger option installed, you will see the Megger screen. This screen shows you the most recent Megger test measurement, as well as the option to Megger Now. For more information, reference *IRMS / Megger*.
- From the Megger screen, press the CONFIG button an additional time. You will now be prompted for a password. The password on all Airport Lighting Company CCRs is "9999". Use the UP and DOWN buttons to change the number above the ↑ up arrow cursor. Press the right DOT button to advance to the next digit. Once the password is entered, push the left DOT button to advance to the menu.

Accessing the Diagnostics Menu

- From the CCR main screen, press the CONFIG button until you see the "Enter Password" screen. Press the CONFIG button once more, for a total of two (2) times on a non-IRMS CCR or three (3) times on an IRMS-equipped CCR.
- While most of the options within this menu will be used only by Airport Light Company representatives during troubleshooting, there are menus that contain logs of the 10 most recent Faults and Warnings, as well as a run-time log.
- The Run-time log can be found by navigating to:
Diagnostics Menu > Operations
- The Fault and Warning logs can be found, respectfully, by navigating to:
Diagnostics Menu > Faults / Warnings



Common CCR Configuration Changes

This section will go over the most common CCR changes that may be warranted in-field. Note that configuration beyond the options covered in this section may cause problems with the normal operation of the CCR. Exercise caution when changing options. For assistance or clarification regarding options within the configuration menu, contact Airport Lighting Company.

Changing the Step Count of the CCR

The CCR will be factory-configured to the brightness step count that is ordered. It may be determined in-field that the factory-configured step count is not appropriate for the applicable circuit and a brightness step count changeover is required.

Note: Follow all appropriate FAA Advisory Circular documentation. Refer to product-specific Advisory Circulars to determine the CCR step count requirement.

To change the step count, navigate to:

Configuration Menu > CCR Config > Number of Steps > [1, 3, 5, 7]

The most common step counts are 3 and 5. Upon changing the step count, the CCR main screen will reflect the accurate step-count nomenclature. 3 step CCRs identify the step counts as B10, B30, and B100, while 5 step CCRs identify the step counts as B1, B2, B3, B4, and B5.

Changing the Remote Control Input Voltage

This is a review of the configuration menu commands from *Installing the Remote Control*. It is recommended to verify the configured CCR control input voltage once the in-field control system voltage is known.

Configuration Menu > CCR Config > Parallel Inputs > [Enable] > Input Voltage > [24v, 120v]



Calibrate Zeros

This command will have the CCR find a zero threshold in the input AC voltage. It is required when making equipment changes to the CCR, or when a part is replaced. **Before completing this calibration:** put the CCR in Local Mode and turn the output off.

Configuration Menu > CCR Config > Calibrate > Zeros > [Execute]

Setting Up Automatic Meggering (If Installed)

This section describes how to navigate to and turn on automatic meggering. The megger can be done manually from the megger screen or automatically by the CCR. For more information, refer to *IRMS / Megger*.

Configuration Menu > Monitor Config > Auto Megger > [Enable] > Auto Measure > [Disabled, When On, When Off, Daily]

Changing IRMS / Megger Warning & Alarm Levels (If Installed)

The CCR is factory set to have an IRMS / Megger warning level of 500kohm, and an alarm of 100kohm. If the levels need to be changed for usage in-field, navigate to the following menu option:

Configuration Menu > Monitor Config > Auto Megger > [Enable] > Warning/Alarm Level > [Adjust]

Options

The Airport Lighting Company CCR can be ordered and factory set with various options. Please refer to the Constant Current Regulator Datasheet for available options. This section will focus on a few common options and their use.

IRMS / Megger

The Insulation Resistance Measurement System (IRMS) functionality is most commonly referred to as megger functionality. This option will allow the CCR to measure the resistance of the connected field circuit to ground, and provide an ohm measurement to the user. This system involves an add-on “Megger Card” that attaches directly to the “Ferroresonant Firing Card” that comes in each CCR, as well as a 2Mohm enclosure-mounted resistor that is distinctive for its large white 40kVDC wire. Note: the megger resistor may get HOT when in use.

The Airport Lighting Company CCR IRMS / Megger will measure up to 2Gohm.

The theory of IRMS / Meggering is that ideally, there is a large resistance between the field circuit and ground meaning the CCR is not trying to operate in a short. This is important for efficiency, general safety, and longevity of equipment.

Note: the “Output Shorted” warning operates independently of the IRMS / Megger.

The value of the current megger reading will be displayed on the CCR main screen, next to the “Temperature” reading. Refer to *Table 5* for more information about the CCR main screen. *Figure 14* shows the megger measurement of a completely open circuit.



Figure 14: Megger Measurement (Open Circuit)

The Megger Screen

The megger screen is accessed by pressing the CONFIG button once. This screen will show some troubleshooting information if needed, but primarily serves as a method to manually run a megger test.



Figure 15: The Megger Screen

Operating the IRMS / Megger Manually

To use the megger manually, push the CONFIG button on the CCR screen. You will be taken to a megger screen, that shows a semi-current measurement in kohm. Push the left DOT button, with the “Measure Now” command above it, to run a fresh megger test. The megger test will take two (2) minutes. Upon completion, the ohm megger measurement will be available on the CCR main screen, to the right of “Temperature” – refer to Table 5.

Note: If the measured resistance is above 2 Gohm, the CCR will only display 2Gohm.

IRMS / Megger Options

While the megger functionality is factory configured and calibrated alongside other CCR options, there are options that can be changed in-field to accommodate each installation scenario.

Automatically Collecting IRMS / Megger Measurements

While the IRMS / Megger can be operated manually from the megger screen, it can also be set up to run automatically. Refer to *Setting Up Automatic Meggering* for more information on setup. If automatic meggering is set up, the measurement is stored and can be retrieved from the CCR main screen.

The CCR comes with 4 total options for automatic measurement:

- **Off:** Turns off automatic measurement
- **When On:** The IRMS will megger at two (2) minute intervals when the output power is on
- **When Off:** The IRMS will megger at two (2) minute intervals when the output power is off
- **Daily:** The IRMS will megger once per day

IRMS / Megger Warning & Alarm Levels

The CCR is set up to give either a warning or alarm to the user depending upon the measurement that is collected from a megger test. Ideally, the resistance in the field circuit will be high – meaning that the circuit is not leaking to ground. The default value for the warning is 500kohm, while the default value for the alarm is 100kohm. For information on changing these values, refer to *Changing IRMS / Megger Warning & Alarm Levels*.

IRMS / Megger Calibration

While the IRMS will come factory pre-calibrated, it may be necessary to re-calibrate at future dates or after catastrophic events (ex. lightning strikes). The calibration procedure does not need to be done upon initial installation of the CCR.

There are 2 calibration tests that are required for the IRMS. Both tests will require moving the Output-terminal-connected megger resistor wire. The first test is a “Calibrate Open”, for which the megger wire needs to be disconnected from the field circuit and isolated. The second test is a “Calibrate Short” test for which the megger resistor wire needs to be grounded.

Note: if not done correctly, re-calibration may cause incorrect values to be returned. Please follow each step closely. For additional information, contact Airport Lighting Company.

- Ensure you have all appropriate personal protective equipment (PPE) for the input voltage of your CCR.
- Put the CCR into Local mode, and turn the output off.
- Open the CCR door and locate the Output terminal that has the large, white 40kVDC megger resistor wire connected to it. Remove the wire and place it in an electrically-isolated location. For example, place a leather work glove over it.
- Close the door and re-lock at least 1 of the 1/4-turn latches.
- After familiarizing yourself with *CCR Configuration*, go to the following location:
Configuration Menu > Monitor Config > Auto Megger > [Enable] > Calibrate Open > [Execute]
- After the calibration has completed, re-open the door to the CCR and relocate the megger resistor wire.
- Either secure or jump the end of the wire directly to a good, stable ground.
- Close the CCR door and re-lock at least 1 of the 1/4-turn latches.
- Navigate to the following location in the CCR menus:
Configuration Menu > Monitor Config > Auto Megger > [Enable] > Calibrate Short > [Execute]
- Once the calibration is done, open the CCR door and reconnect the megger resistor wire to the Output terminal where it was initially located.
- Close the CCR door. Push the CONFIG button once to get to the megger screen.
- Press the left DOT button to execute a “Measure Now” command and wait two (2) minutes for the test to run.
- Verify the displayed measurement against the value from an independent, calibrated IRMS / Megger unit.
- If the numbers match, your calibration is complete. If the displayed measurement does not match the independent unit, repeat the calibration process. If issues persist, contact Airport Lighting Company.

Lamp Out

The Lamp Out feature is on the L829 only. This feature is enabled in factory, but must be calibrated in field since each circuit is unique. Note: Refer to FAA AC150/5345-10H, Section 3.5.I for complete information about circuit lamp out setup. In the event that a lamp out configuration is set up in a circuit that does not conform to FAA AC150/5345-10H, Section 3.5.I, the CCR will be able to measure VA drops but may result in erroneous lamp out numbers. In that instance, refer to *VA Changes*.

- The Lamp Out feature causes the CCR to run calculations based on airfield circuit measurements. The results of the calculations will identify whether a lamp has gone out in field.
- The Lamp Out measurement can be found on the CCR main screen. See *The Main Screen* for more information.
- Complete the setup procedure in the following section to correctly calibrate the CCR for your individual circuit.

Note: It is recommended to disable the Lamp Out function if it will not be used in-field. This will prevent rogue warnings and alarms from bad calibrations. To disable this function, navigate to:

Configuration Menu > Monitor Config > Lamp Outage > [Disable]

Calibrating a Lamp Out Configuration

This calibration must be done on an already- setup CCR that is connected to an airfield circuit. Put the CCR into Local mode and cycle through the brightness steps to visually verify that each light fixture is operational. Once you have a known, good circuit you can proceed. Note: The lights on the airfield circuit will automatically cycle through brightness steps as part of the calibration.

- Put the CCR into Local mode and turn the output off.
- Navigate to the Lamp Outage Menu:
Configuration Menu > Monitor Config > Lamp Outage > [Enable]
- The Lamp Outage menu contains a few variables that will be circuit-specific and must be entered. First, change the Number of Lamps to the number of fixtures of the circuit:
Lamp Outage Menu > Number of Lamps > [Adjust]
- The warning and alarm levels of the lamp out are preset. The warning will come up with 2 lamps out, and the alarm will come up with 4 lamps out. Depending upon the airport requirements, these can be changed:
Lamp Outage Menu > Warning Level / Alarm Level > [Adjust]
- Once the number of lamps, warning level, and alarm level are set, complete the calibration:
Lamp Outage Menu > Calibrate LO & VA > [Execute]
- The CCR will run through a test that cycles through different brightness steps.
- To verify the calibration, turn off the CCR and perform lock out / tag out procedures.
- In field: either disconnect the secondaries on an amount of isolation transformers, or remove from fixtures the quantity of lamps, that equal the number of fixtures of your lamp out warning level.
- Return to the CCR and re-energize. The CCR will read the airfield circuit and provide a lamp out number. If the number is correct, your calibration is complete. Disconnect the CCR power and reinstall the fixtures or lamps that were previously disconnected.
- If the lamp out measurement is not correct, a Lamp Out Adjust must be completed. The Adjust command is found in the Lamp Outage Menu:
Lamp Outage Menu > Adjust > [Execute] > [Enter actual number of disconnected secondaries or lamps]
- The process of disconnecting fixture secondaries or lamps and completing a Lamp Out Adjust may be completed 3 times, to establish an accurate curve that the CCR can scale to during calculation.

VA Changes

The VA Changes feature is on the L829 only. This feature must be calibrated in field since each circuit is unique. The VA Changes function is intended to read airfield circuit Volt Amp (VA) draw and provide an alarm upon crossing a low or high threshold.

The purpose is to determine if circuit fixtures are drawing too little, or too much power as this can be an indication of problematic equipment.

The low and high thresholds for the VA Changes function are setup to comply with FAA AC150/5345-10H, and will alarm the CCR at $\pm 10\%$ calibrated nominal circuit VA. For this function to work, a calibration must be completed in field with a fully functional circuit.

Note: It is recommended to disable the VA Changes function if it will not be used in-field. This will prevent rogue warnings and alarms from bad calibrations. To disable this function, navigate to:

Configuration Menu > Monitor Config > VA Changes > [Disable]

If the CCR will also be using the Lamp Out feature: refer to *Lamp Out*. The Lamp Out calibration will also calibrate the VA Changes feature. No additional calibration is required.

If the CCR will not be using the Lamp Out feature, complete the following calibration:

- Put the CCR into Local mode and turn the output off.
- Navigate to the VA Changes Menu:
Configuration Menu > Monitor Config > VA Changes > [Enable]
- The VA Changes menu has options for low and high alarm thresholds, as well as a calibration command. Changing the low and high alarm levels is not recommended.
- Navigate to the “Calibrate LO & VA” command and execute it.
- The CCR will run through a test that cycles through different brightness steps.
- Once the CCR has completed the calibration, it will be fully setup and ready to use.

CC as Enable

Note: This option is applicable only on CCRs with firmware 1.06 and newer

The CC as Enable function is used to allow a remote switch to interrupt the CCR output. With this function enabled, the CCR will not engage the output power unless power is provided to the CC terminal block. The power to CC is to be provided from the same source as the brightness step control.

If a remote switch is actuated while the CCR is running, the output power will safely shut down and an “Output Disabled” warning will be provided to the user on the CCR front panel.



Figure 16: Output Disabled Warning

The CC as Enable option is a preferable option to interlock CCR output with additional equipment such as the Airport Lighting Company Circuit Selector Switch.

While the CCR is in an “Output Disabled” state, the user will not be able to command the CCR to any brightness step, regardless of whether the command is Remote or Local.

To enable or disable this function, navigate to:

Configuration Menu > CCR Config > Parallel Inputs > CC as Enable > [Enable / Disable]

Warnings, Alarms, and Faults

The CCR will automatically determine when conditions exist either within the CCR or the attached circuit to prompt a warning, alarm, or fault.

Warnings and alarms will cause the yellow light on the WARNING button on the CCR display to turn on. Pressing the button will cycle through any currently-active warnings and alarms. They will be displayed on line 1 of the screen.

Faults will cause the red light on the FAULT button on the CCR display to turn on. Pressing the button will cycle through any currently-active faults. They will be displayed on line 1 of the screen.

A history of the 10 most recent warnings and faults can be found in the Diagnostics Menu, for more information refer to *Accessing the Diagnostics Menu*.

Warnings and Alarms

When the CCR determines a warning or setpoint alarm, it will engage the indicator light and the warning will be shown on line 1 of the CCR display. The CCR will continue to operate in the event of a warning. Although the CCR will continue operating, warning conditions must still be noted and fixed.

Allowing the CCR to operate in a warning state may cause problems for efficiency, general safety, and longevity of equipment.

Table 5 contains warning and alarm descriptions, and steps to fix them. For additional information or help, contact Airport Lighting Company.

Warning and Alarm Table

Always maintain safe working conditions by using appropriate personal protective equipment (PPE) where necessary.

The warning and alarm code table is set up in alphabetic order. Fully read the description and steps to fix thoroughly before completing work. Complete all steps to ensure a proper fix. For more information, contact Airport Lighting Company.

Warning	Description	Steps to Fix
CCR Not Remote	The button located on the CCR door is not in the Remote position.	<ul style="list-style-type: none"> Put the CCR into Remote mode.
Comm Loss – Failsafe	This warning will occur when a CCR is being controlled on Channel A or Channel B, and the signal is lost. The CCR will go to a failsafe setting.	<ul style="list-style-type: none"> Ensure the command system is operational and sending the correct commands. Operate the CCR in Local mode.
Comms 24V Missing	<p>The CCR was set up to monitor a 24VDC backup power supply. This warning occurs when the monitor is enabled and the 24VDC backup is missing.</p> <p>If no 24VDC backup power supply is installed, this warning will only be seen if the monitor is enabled in the Configuration Menu.</p>	<ul style="list-style-type: none"> Verify the backup power supply is operational using a DMM. If no backup supply is connected: the option for monitoring was unintentionally enabled. To disable, navigate to: Configuration Menu > Monitor Config > Comms 24V Monitor > [Disable]
CSS 123456 Current	The CSS Current warning will occur if one of the CSS circuits is commanded off and the Current Sensor for that circuit measures current. The CCR will provide the CSS Current warning for applicable channels.	<ul style="list-style-type: none"> Ensure the CSS equipment is operating correctly. Measure the circuit current with a DMM to determine if output current is present. Verify the output current calibration. Refer to <i>How to Determine if Recalibration is Needed</i>.

Warning	Description	Steps to Fix
CSS 123456 Error	The CSS Error warning will occur only if CSS has been configured on the CCR. If the CSS's current sensors cannot be found, the CCR will provide the CSS Error for applicable channels.	<ul style="list-style-type: none"> • Ensure the CSS equipment is operating correctly. • Ensure all Current Sensors (CS) are operational.
CSS 123456 No Currnt	The CSS No Currnt warning will occur if one of the CSS circuits is commanded on and the Current Sensor for that circuit does not measure current. The CCR will provide the CSS Error for applicable channels.	<ul style="list-style-type: none"> • Ensure the CSS equipment is operating correctly. • Measure the circuit current with a DMM to determine if output current is present. • Verify the output current calibration. Refer to <i>How to Determine if Recalibration is Needed</i>.
CSS Input Card Failure	The CSS Input card is not installed or has failed its power-on test.	<ul style="list-style-type: none"> • If CSS was installed, contact Airport Lighting Company. • If CSS was not installed: the option for CSS functionality was unintentionally enabled. To disable, navigate to: Configuration Menu > CSS Config > [Disable]
Door Open	<p>The CCR door is open. The door safety interlock is mounted on the top, right opening of the CCR enclosure.</p> <p>The CCR will not operate while this warning is active. If the door is opened while the CCR is running, it will turn the output power off.</p>	<ul style="list-style-type: none"> • Close the door. • For service with the CCR door open: pull the door switch plunger laterally out (toward you).



Warning	Description	Steps to Fix
Firing Card Warning	The CCR has determined an issue with the Firing Card.	<ul style="list-style-type: none"> • Turn off power to the CCR. Once power has discharged and all LEDs are out, remove the green terminal blocks from the firing card. Ensure all screws are tight. Reinstall the terminal blocks. Ensure they are seated fully. Unscrew the serial cable and remove it. Reinstall the cable and screw in the thumbscrews.
High Input Voltage	The voltage input that feeds the CCR is higher than expected. This alarm defaults at 10% over nominal input voltage.	<ul style="list-style-type: none"> • Check the input voltage calibration: refer to <i>How to Determine if Recalibration is Needed</i>. • If the calibration is correct, consult an electrician to diagnose building power problems.
High Temperature	<p>The internal DCMU temperature threshold has been met. The CCR is running too hot, or environmental conditions are causing heat buildup.</p> <p>This warning defaults to 60°C.</p>	<ul style="list-style-type: none"> • Do a visual inspection of the CCR enclosure. Look for blockages of vent grating on the front door, enclosure top, and enclosure rear. • Do a visual inspection of the inside of the CCR. Look for blockage of airflow around the DCMU. • Blow out dust with standard electronics compressed-gas duster. Vacuum out all dust. • For prolonged hot environmental conditions, install temporary ventilation around the CCR to prevent damage from heat.
Input Card Error	The CCR has determined an error with the input card on the DCMU.	<ul style="list-style-type: none"> • Turn off power to the CCR. Once power has discharged and all LEDs are out, remove the green terminal blocks from the bottom of the DCMU. Ensure all screws are tight. Reinstall the terminal blocks. Ensure they are seated fully.



Warning	Description	Steps to Fix
Lamp Alarm	<p>The lamp out alarm threshold has been met. Refer to <i>Lamp Out</i> for more information about the Lamp Out feature.</p> <p>The circuit has lamps out.</p>	<ul style="list-style-type: none"> The connected circuit has lamps out that need to be replaced. If no circuit lamps are out, or the incorrect number is displayed, refer to <i>Lamp Out</i> for information and calibration procedures.
Lamp Warning	<p>The lamp out warning threshold has been met. Refer to <i>Lamp Out</i> for more information about the Lamp Out feature.</p> <p>The circuit has lamps out.</p>	<ul style="list-style-type: none"> The connected circuit has lamps out that need to be replaced. If no circuit lamps are out, or the incorrect number is displayed, refer to <i>Lamp Out</i> for information and calibration procedures.
Local Comms Mode	<p>There is a computer running the CCR Configurator plugged into the DCMU through the RS232 port.</p>	<ul style="list-style-type: none"> Close the Configurator. Disconnect the serial cable.
Low Input Voltage	<p>The voltage input that feeds the CCR is lower than expected. This alarm defaults at 5% under nominal input voltage.</p>	<ul style="list-style-type: none"> Check the input voltage calibration: refer to <i>How to Determine if Recalibration is Needed</i>. If the calibration is correct, consult an electrician to diagnose building power problems.
Megger Alarm	<p>The IRMS / Megger alarm threshold has been met. Refer to <i>IRMS / Megger</i> and <i>IRMS / Megger Options</i> for more information about the IRMS / Megger feature.</p> <p>This alarm defaults to 100kohm.</p>	<ul style="list-style-type: none"> Verify the CCR megger measurement with a known, calibrated IRMS / Megger unit. Refer to <i>IRMS / Megger Calibration</i>. If calibration is correct, consult an electrician to determine faults in the airfield circuit.



Warning	Description	Steps to Fix
Megger Fault	<p>The CCR has determined an issue with the IRMS / Megger card.</p> <p>If IRMS / Megger functionality is not installed, this warning will only be seen if the IRMS is enabled in the Configuration Menu.</p>	<ul style="list-style-type: none"> • Turn off power to the CCR. Once power has discharged and all LEDs are out, ensure the megger card connection screws are tight. • If IRMS / Megger functionality was not installed: the option for IRMS functionality was unintentionally enabled. To disable, navigate to: Configuration Menu > Monitor Config > Auto Megger > [Disable]
Megger Warning	<p>The IRMS / Megger warning threshold has been met. Refer to <i>IRMS / Megger</i> and <i>IRMS / Megger Options</i> for more information about the IRMS / Megger feature.</p> <p>This warning defaults to 500kohm.</p>	<ul style="list-style-type: none"> • Verify the CCR megger measurement with a known, calibrated IRMS / Megger unit. Refer to <i>IRMS / Megger Calibration</i>. • If calibration is correct, consult an electrician to determine faults in the airfield circuit.
Mismatch – Failsafe	<p>This warning may occur only on CCRs with multiple communications channels configured. If Channel A and Channel B are sending different commands to the same CCR, the CCR will go to a failsafe setting.</p>	<ul style="list-style-type: none"> • Ensure the command system is sending only one command to the CCR. • Operate the CCR in Local mode.
No Comms Ch A	<p>Channel A of the communications card is not receiving a signal with the CCR in Remote.</p> <p>If no communications card is installed, this warning will be seen only if the Comms Config menu is Enabled in the Configuration Menu.</p>	<ul style="list-style-type: none"> • Verify the communications system and wiring is operational. • If no communications card is installed: the setting for Comms Config was unintentionally enabled. To disable, navigate to: Configuration Menu > Comms Config > [Disable]

Warning	Description	Steps to Fix
No Comms Ch B	<p>Channel B of the communications card is not receiving a signal with the CCR in Remote.</p> <p>If no communications card is installed, this warning will be seen only if the Comms Config menu is Enabled in the Configuration Menu.</p>	<ul style="list-style-type: none"> Verify the communications system and wiring is operational. If no communications card is installed: the setting for Comms Config was unintentionally enabled. To disable, navigate to: Configuration Menu > Comms Config > [Disable]
No Input Voltage	<p>No input voltage can be detected. This warning will be displayed only if a 24VDC backup power supply is powering the DCMU.</p> <p>The most likely cause is the CCR feed breaker being off.</p>	<ul style="list-style-type: none"> Turn the feed breaker on. Use a DMM to determine if voltage is present.
Off Current High	<p>The displayed output current is greater than .1 amps when the CCR output is turned off.</p>	<ul style="list-style-type: none"> Verify the output current calibration. Refer to <i>How to Determine if Recalibration is Needed</i>.
Output Card Fault	<p>The CCR has determined an error with the output card on the DCMU.</p>	<ul style="list-style-type: none"> If CSS was installed, contact Airport Lighting Company. If CSS was not installed: the option for CSS functionality was unintentionally enabled. To disable, navigate to: Configuration Menu > CSS Config > [Disable]
Output Disabled	<p>The "CC as Enable" function is enabled and there is no power being provided to the CC terminal.</p>	<ul style="list-style-type: none"> Verify if power to the CC terminal was intentionally removed. Resolve conditions that caused the power to be removed. For example, if the CCR is interlocked with a CSS door switch, close the CSS door. If CC as Enable was unintentionally enabled, navigate to: Configuration Menu > CCR Config > Parallel Inputs > CC as Enable > [Disable]



Warning	Description	Steps to Fix
Output Shorted	<p>The CCR is providing output current, but the voltage is minimal.</p> <p>The most likely cause is an S-1 Cutout shorting the output, or a forgotten wire jumper used during setup/calibration.</p> <p>The CCR will operate in a short, and is providing power to the output terminals.</p>	<ul style="list-style-type: none"> • TURN OFF POWER to the CCR before modifying the output circuit. • Ensure the circuit S-1 Cutout is set for normal operation. • Open the CCR door and visually inspect for a short, such as a leftover wire jumper from installation. • If there is still a short, disconnect airfield circuit and test for a circuit short.
Tolerance Alarm	<p>The output current is lower or higher than expected at the operating brightness step. This warning defaults to ± 1 amps.</p>	<ul style="list-style-type: none"> • Verify the output current calibration. Refer to <i>How to Determine if Recalibration is Needed</i>.
Tolerance Warning	<p>The output current is lower or higher than expected at the operating brightness step. This warning defaults to ± 0.05 amps.</p>	<ul style="list-style-type: none"> • Verify the output current calibration. Refer to <i>How to Determine if Recalibration is Needed</i>.
Unknown Warning	<p>The CCR has determined that warning conditions exist, but no description exists.</p>	<ul style="list-style-type: none"> • Contact Airport Lighting Company.
VA High	<p>The high threshold for VA Changes has been met. See <i>VA Changes</i> for more information.</p> <p>This warning defaults to 10%.</p>	<ul style="list-style-type: none"> • Verify the VA Changes calibration. Refer to <i>VA Changes</i>. • Put the CCR into Local mode and cycle through each step to determine if the issue persists at each brightness. • While at highest brightness step, do a visual inspection of field equipment to determine if the fixtures have been damaged.

Warning	Description	Steps to Fix
VA Low	<p>The low threshold for VA Changes has been met. See <i>VA Changes</i> for more information.</p> <p>This warning defaults to 10%.</p>	<ul style="list-style-type: none"> • Verify the VA Changes calibration. Refer to <i>VA Changes</i>. • Put the CCR into Local mode and cycle through each step to determine if the issue persists at each brightness. • While at highest brightness step, do a visual inspection of field equipment to determine if the fixtures have been damaged.
Wrong Brightness	<p>The output current does not match the range for the selected brightness step.</p> <p>Press the warning button to view the selected and actual brightness settings.</p>	<ul style="list-style-type: none"> • Verify the output current calibration. Refer to <i>How to Determine if Recalibration is Needed</i>.

Table 6: Warning and Alarm Codes

Faults

When the CCR determines a fault has occurred, it will engage the red indicator light on the FAULT button and the fault will be shown on line 1 of the CCR display. The CCR **will not continue to operate** in the event of a fault. All fault conditions must be addressed to resume normal operation of the CCR.

Table 7 contains fault descriptions, and steps to fix them. For additional information or help, contact Airport Lighting Company.

Fault Table

Always maintain safe working conditions by using appropriate personal protective equipment (PPE) where necessary.

The fault code table is set up in alphabetic order. Fully read the description and steps to fix thoroughly before completing work. Complete all steps to ensure a proper fix. For more information, contact Airport Lighting Company.

Fault	Description	Steps to Fix
Current Asymmetry	The current asymmetry fault is caused when the output waveform has an unequal differential of positive power to negative power.	<ul style="list-style-type: none"> Complete a “Calibrate Zeros” calibration. Refer to <i>Calibrate Zeros</i> for more information. If the problem persists, contact Airport Lighting Company.
Door Open Trip	The CCR door switch interlock was tripped while the CCR was running.	<ul style="list-style-type: none"> Close the door.

Fault	Description	Steps to Fix
No Current	<p>The CCR has tried to generate an output current but failed to. This fault will occur if the DCMU engages the output and the current stays below 1 amp for approximately 3 seconds.</p> <p>Under normal operation, this is a symptom of a problem with the CCR.</p>	<ul style="list-style-type: none"> • With the CCR power off, check each installed fuse. For a list of fuses and ratings, refer to <i>Fuses</i>. • Turn off power to the CCR. Once power has discharged and all LEDs are out, remove the green terminal blocks from the firing card and DCMU. Ensure all screws are tight. Reinstall the terminal blocks. Ensure they are seated fully. Unscrew the serial cable at both ends and remove it. Reinstall the cable and screw in the thumbscrews.
No Input Voltage	<p>The CCR has lost input voltage. This warning will be displayed only if a 24VDC backup power supply is powering the DCMU.</p> <p>The most likely causes of this fault:</p> <ul style="list-style-type: none"> • The CCR feed breaker tripped • Partial or full loss of site power 	<ul style="list-style-type: none"> • Determine if the CCR feed breaker tripped. If it has, safely turn the breaker back on, put the CCR into Local mode, and turn off the output. View the warning history in the Diagnostics Menu, refer to <i>Accessing the Diagnostics Menu</i> for more information. The warning history may provide insight to the cause of tripping the feed breaker.
Open Circuit	<p>The CCR has determined that it is trying to drive current into an open circuit. This fault will occur when the output voltage increases but the output current does not scale to the selected setting.</p> <p>This fault will generally occur only if there is a problem with the airfield circuit.</p>	<ul style="list-style-type: none"> • If this error occurs during CCR setup, refer to <i>Installing the CCR</i> for more information. • If this error occurs during normal operation, it must be determined if the issue is with the CCR or airfield circuit. Put the CCR in Local mode, and then disconnect CCR supply power. Within the CCR, install a wire jumper, or pull an S-1 Cutout handle, like described in <i>Terminating CCR Connections</i>. Re-energize the CCR, and turn it on to the first brightness step. If the CCR continues to present the fault, contact Airport Lighting Company. Otherwise, consult an electrician to diagnose problems with the airfield circuit.

Fault	Description	Steps to Fix
Over Current	<p>Per FAA specifications, this fault will occur in one of two conditions. The output current must meet one of the following:</p> <ul style="list-style-type: none"> • Be 5% over nominal current output for 5 seconds • Be 25% over nominal current output for 1 second <p>This fault may be caused by hardware failures.</p>	<ul style="list-style-type: none"> • Put the CCR into Local mode and turn output off. Open the CCR door and do a visual inspection for signs of damage. Pull the door switch plunger laterally toward you to bypass the door interlock. Turn the CCR on to the first brightness step. Check to see if the solid state relay (SSR) coil indicator is lit up. • Contact Airport Lighting Company.
Over Voltage	<p>The CCR has detected that the output voltage is higher than the fault threshold. The default fault is at 15% over nominal output voltage. The nominal output voltage for the highest step count is listed on the CCR nameplate.</p> <p>This fault will generally occur if the airfield circuit has been damaged and is causing electrical arcing.</p>	<ul style="list-style-type: none"> • Put the CCR in Local mode, and then disconnect CCR supply power. Within the CCR, install a wire jumper, or pull an S-1 Cutout handle, like described in <i>Terminating CCR Connections</i>. Re-energize the CCR, and turn it on to the first brightness step. If the CCR continues to present the fault, contact Airport Lighting Company. • If the CCR does not determine the fault with the output shorted, consult an electrician to diagnose the airfield circuit.
Time Asymmetry	<p>The time asymmetry fault is caused then the output waveform has sinusoidal half-cycles that are not equal in period (time).</p>	<ul style="list-style-type: none"> • Complete a “Calibrate Zeros” calibration. Refer to <i>Calibrate Zeros</i> for more information. • If the problem persists, contact Airport Lighting Company.
Unknown Fault	<p>The CCR has determined that fault conditions exist, but no description exists.</p>	<ul style="list-style-type: none"> • Contact Airport Lighting Company.

Table 7: Fault Table

Troubleshooting

The troubleshooting table and guides in this section are intended to include potential fixes for problems that go beyond the codes provided by the CCR in *Warnings, Alarms, and Faults*.

If the CCR is providing a warning or fault, refer to *Warnings, Alarms, and Faults*.

If the problem you're experiencing is not listed in this section, or if the included steps to fix do not address the issue, contact Airport Lighting Company.

Troubleshooting Table

Always maintain safe working conditions by using appropriate personal protective equipment (PPE) where necessary.

Follow all lock out / tag out procedures as necessary.

Fully read the description and steps to fix thoroughly before completing work. Complete all steps to ensure a proper fix. For more information, contact Airport Lighting Company.

Problem	Likely Cause(s)	Steps to Fix
The CCR will not turn on.	<ul style="list-style-type: none"> CCR supply voltage feeder is not on. Blown fuses within the CCR The control transformer is not providing 15VAC on pins 11 & 12 Faulty DCMU 	<ul style="list-style-type: none"> Check to see if the CCR feeder supply breaker has tripped. Verify the supply voltage with a DMM With all power off, verify the integrity of the electrical connections. Check the CCR fuses, refer to <i>Fuses</i> for more information. With power on, check the control transformer voltage on pins 11 and 12. Refer to <i>Turning the CCR on for the First Time</i> for more information. Replace DCMU if a spare is available.

Problem	Likely Cause(s)	Steps to Fix
Display is blank / the CCR display buttons don't work.	<ul style="list-style-type: none"> There is a bad connection between the DCMU and the CCR display 	<ul style="list-style-type: none"> First, see if the CCR operates in Remote mode. If it doesn't, refer to <i>The CCR will not turn on</i>. If the CCR operates in Remote mode, try unplugging and reconnecting display cable at either end.
All DCMU LEDs are flashing at the same time	<ul style="list-style-type: none"> The internal DCMU power supply card is shorting. The internal DCMU power supply card capacitors discharged. 	<ul style="list-style-type: none"> If all of the DCMU LEDs are flashing on and off simultaneously, it is likely that there is a component drawing more power from the DCMU than it's designed to provide. To determine if this is true, complete the following steps: <ul style="list-style-type: none"> Turn off power to the CCR. Wait for power to completely discharge by monitoring the LEDs. Once they are all off, power is no longer present. Unplug the serial cable connected to the left side of the DCMU, and the firing card. The thumbscrews need to be loosened before removal. Reapply power to the CCR. If the issue persists, replace the DCMU if a spare is available. If the issue is resolved with the serial cable disconnected, replace the serial cable, firing card, and megger card (if installed) one at a time to determine the cause of the problem.
Regulated current is less than 2.8 and cannot be increased	<ul style="list-style-type: none"> Solid state relay (SSR) has failed. The output current calibration is not correct. 	<ul style="list-style-type: none"> Using a DMM, verify the output current. If the current measured on the DMM does not match the CCR displayed current, refer to <i>How to Determine if Recalibration is Needed</i>. If the output current calibration is correct, the issue may be with the SSR. Disconnect power from the CCR. At the SSR, disconnect one of the inductor lines, IND A or IND B, that are connected to the contact side of the SSR. Use a DMM to check the SSR contact – it should be normally open. If it isn't, the SSR was damaged. Contact Airport Lighting Company.

Problem	Likely Cause(s)	Steps to Fix
Output current is too low for the selected brightness step	<ul style="list-style-type: none"> The output current needs to be recalibrated. The CCR is overloaded. 	<ul style="list-style-type: none"> Using a DMM, verify the output current. If the current measured on the DMM does not match the CCR displayed current, refer to <i>How to Determine if Recalibration is Needed</i>. To see if the CCR is overloaded with the connected circuit, complete the following steps: Put the CCR in Local mode, and then disconnect CCR supply power. Within the CCR, install a wire jumper, or pull an S-1 Cutout handle, like described in <i>Terminating CCR Connections</i>. Re-energize the CCR, and turn it on to the first brightness step. If the CCR continues to present the fault, contact Airport Lighting Company. If the problem resolves itself, it is likely that the airfield circuit is overloading the CCR.
Remote Control does not work or is going to an incorrect brightness step	<ul style="list-style-type: none"> For CCRs with communications cards installed: there may have been a loss of signal to the CCR. Problems exist with the remote control system. There may be a problem with the remote control terminations within the CCR. 	<ul style="list-style-type: none"> Put the CCR into Local mode. Cycle through the brightness steps to verify that the CCR is operational. If the CCR operates ideally in Local mode, the problem is likely to be with the control system. Verify that all remote control system connections are good. Check for tightness of screws on DIN rail terminal blocks. Try unplugging and reconnecting connections on the communications card (if installed). Verify that the remote control wiring is correct. Refer to <i>Installing the Remote Control</i> for more information.

Table 8: Troubleshooting Chart

Restoring Known Good Settings

The CCR includes two (2) different sets of stored information. Each set includes a configuration and calibration setting that the CCR may be returned to, if options are mistakenly changed while in-field.

The “Factory” setting will restore the CCR to a blank-slate condition, and each part of the CCR will require manual reconfiguration. The “Known Good” setting will restore the CCR to the configuration that is saved by Airport Lighting Company during the factory setup and testing procedure. Please note that unless saved, field-made changes will not be retained if “Known Good” settings are restored.

Restoring a Known Good Configuration

If you experience problems after changing the settings of the CCR after it is in field, and wish to return it to the Airport Lighting Company-setup settings, navigate to the following menu option:

Configuration Menu > System Commands > Known Good Settings > Restore Config > [Execute]

This will have the CCR return to the most recent saved configuration. The CCR will ship with a factory-saved configuration that may be overwritten in field. Note: this will not affect the CCR calibration. This is useful for instances where an option was enabled or disabled, and it is unknown what setting it was.

Restoring a Known Good Calibration

If the CCR is presenting problems with the measurements displayed on-screen vs verified field measurements, it may be helpful to restore the Airport Lighting Company-setup calibration. To do so, navigate to the following menu option:

Configuration Menu > System Commands > Known Good Settings > Restore Calib > [Execute]

This will have the CCR return to the previously setup-and-saved calibration. The CCR will ship with a factory-saved calibration that may be overwritten in field. Note: this will not affect the CCR configuration.

Completing In-Field Recalibrations

This section is intended to provide information on how to recalibrate the output current, output voltage, input current, and input voltage. For the calibration of other CCR systems, refer to the appropriate sections within this manual:

- Calibrate Zeros
- IRMS / Megger Calibration
- Lamp Out Calibration
- VA Changes Calibration

In-field recalibrations should be completed only upon necessity. Changing the calibration values may result in hazardous conditions within the field circuit or damage to equipment.

How to Determine if Recalibration is Needed

If you suspect that the CCR measurements are not accurately reflecting the actual conditions of CCR input or output, complete the following steps:

- To Verify Output Current
 - Connect a known, calibrated current clamp to a known, calibrated digital multimeter (DMM) and place the clamp on one leg of the output circuit wire.
 - Put the CCR into Local mode and turn it on to the first brightness step.
 - Check the DMM-measured value against the CCR-measured value. Due to a difference in the fidelity of measuring in the different equipment, you may see a slight difference. Log the measured numbers.
 - Put the CCR on the highest brightness step. Log the measured numbers.
 - If the numbers are consistently more than .5 amps different, you may want to consider recalibration.

- To Verify Output Voltage
 - Put the CCR into Local mode and turn the output power off.
 - Open the CCR door and pull the door switch plunger toward you laterally to bypass the safety interlock.
 - Turn the CCR on to any brightness step.
 - Using voltage probes on a known, calibrated DMM, measure the AC voltage across V1 and V2 on the 11-pin firing card terminal block by probing the screw heads. Multiply the measured voltage by the “V1-V2 Output Voltage Measurement Factor” provided on the CCR Datasheet at the end of this manual. If the factor is not available, contact Airport Lighting Company.
 - If the calculated voltage is not within 5% of the CCR-displayed output voltage, you may want to consider recalibration.

- To Verify Input Current
 - This will be necessary only on CCRs with an Input CT installed.
 - Connect a known, calibrated current clamp to a known, calibrated digital multimeter (DMM) and place the clamp on the input circuit wire.
 - Put the CCR into Local mode and turn it on to the first brightness step.
 - Check the DMM-measured value against the CCR-measured value. Due to a difference in the fidelity of measuring in the different equipment, you may see a slight difference. Log the measured numbers.
 - Put the CCR on the highest brightness step. Log the measured numbers.
 - If the numbers are consistently more than .5 amps different, you may want to consider recalibration.

- To Verify Input Voltage
 - Put the CCR into Local mode and turn the output power off.
 - Open the CCR door and pull the door switch plunger toward you laterally to bypass the safety interlock.
 - Turn the CCR on to any brightness step.
 - Using voltage probes on a known, calibrated DMM, measure the input voltage. It may be measured at the contactor, at the power-side fuse block, or on the control transformer. Log the measured numbers.
 - Put the CCR on the highest brightness step. Log the measured numbers.
 - If the numbers are consistently more than 5% different, you may want to consider recalibration.

Calibrating Output Current

Before continuing, refer to *How to Determine if Recalibration is Needed*. If it is determined that recalibration is required, complete the following steps fully to ensure the most accurate results. Read all steps before beginning. Contact Airport Lighting Company for additional information as needed.

Note: a resistor load bank, such as can be provided by Airport Lighting Company, is recommended to provide a purely-resistive load to the CCR during calibration. Ideally, the CCR should be loaded at 100% of its kW rating for the most accurate calibration.

- Before doing a full recalibration, complete a “Calibrate Zeros” of the CCR. Refer to *Calibrate Zeros*. Once the Calibrate Zeros is done, check to see if the reading discrepancy still exists. If it does, continue.
- Connect a known, calibrated current clamp to a known, calibrated digital multimeter (DMM) and place the clamp on the output circuit wire.
- Connect a load bank to the CCR.
- Put the CCR into Local mode.
- Navigate to the following menu, but do not enter the “Output Current” screen yet:
Configuration Menu > CCR Config > Calibrate > Output Current
- The LOCAL UP and LOCAL DOWN arrows will still operate while in the menu, allowing for easier calibration. Put the CCR on the lowest brightness step.
- Once the CCR is on the lowest brightness step, push the left DOT button to enter the “Output Current” screen.
- Check the DMM-measured current value. Use the UP and DOWN arrows below the screen to adjust the calibration value. Once the values match, push the left DOT button to accept.
- Put the CCR on the highest brightness step, while staying in the calibration menu.
- Check the DMM-measured current value. Use the UP and DOWN arrows below the screen to adjust the calibration value. Once the values match, push the left DOT button to accept.
- Cycle through the brightness steps, and verify the new calibration with the DMM. If the calibration is now acceptable, push the right DOT button until you’re asked to Record Changes, to which you need to execute Yes.

- If the calibration needs additional fine-tuning, complete the calibration procedure again.
- If the calibration procedure does not yield acceptable results, you may want to restore a known good calibration. Refer to *Restoring a Known Good Calibration* for more information.

Calibrating Output Voltage

Before continuing, refer to *How to Determine if Recalibration is Needed*. If it is determined that recalibration is required, complete the following steps fully to ensure the most accurate results. Read all steps before beginning. Contact Airport Lighting Company for additional information as needed.

Note: a resistor load bank, such as can be provided by Airport Lighting Company, is recommended to provide a purely-resistive load to the CCR during calibration. Ideally, the CCR should be loaded at 100% of its kW rating for the most accurate calibration.

- Before doing a full recalibration, complete a “Calibrate Zeros” of the CCR. Refer to *Calibrate Zeros*. Once the Calibrate Zeros is done, check to see if the reading discrepancy still exists. If it does, continue.
- Connect a load bank to the CCR.
- Put the CCR into Local mode.
- Open the CCR door and pull the door switch plunger toward you laterally to bypass the safety interlock.
- Locate the V1 and V2 wires that connect to the firing card through an 11-position green, removable terminal block. This calibration requires measuring AC voltage across those two screwheads while the CCR is on, while the terminal block is plugged in.
- Navigate to the following menu, but do not enter the “Output Voltage” screen yet:
Configuration Menu > CCR Config > Calibrate > Output Voltage
- The LOCAL UP and LOCAL DOWN arrows will still operate while in the menu, allowing for easier calibration. Put the CCR on the lowest brightness step.
- Once the CCR is on the lowest brightness step, push the left DOT button to enter the “Output Voltage” screen.
- Using voltage probes on a known, calibrated DMM, measure the AC voltage across V1 and V2 on the 11-pin firing card terminal block. Multiply the measured voltage by the “V1-V2 Output Voltage Measurement Factor” provided on the CCR Datasheet at the end of this manual. If the factor is not available, contact Airport Lighting Company.
- Use the UP and DOWN arrows below the screen to adjust the calibration value to the calculated value. Once the values match, push the left DOT button to accept.
- Put the CCR on the highest brightness step, while staying in the calibration menu.
- Once again, multiply the DMM-measured voltage by the V1-V2 Output Voltage Measurement Factor. Use the UP and DOWN arrows below the screen to adjust the calculated value. Once the values match, push the left DOT button to accept.

- Cycle through the brightness steps, and verify the new calibration. If the calibration is now acceptable, push the right DOT button until you're asked to Record Changes, to which you need to execute Yes.
- If the calibration needs additional fine-tuning, complete the calibration procedure again.
- If the calibration procedure does not yield acceptable results, you may want to restore a known good calibration. Refer to *Restoring a Known Good Calibration* for more information.

Calibrating Input Current

Before continuing, refer to *How to Determine if Recalibration is Needed*. If it is determined that recalibration is required, complete the following steps fully to ensure the most accurate results. Read all steps before beginning. Contact Airport Lighting Company for additional information as needed.

Note: a resistor load bank, such as can be provided by Airport Lighting Company, is recommended to provide a purely-resistive load to the CCR during calibration. Ideally, the CCR should be loaded at 100% of its kW rating for the most accurate calibration.

Note: This calibration may be completed only if the CCR has an input CT installed.

- Before doing a full recalibration, complete a "Calibrate Zeros" of the CCR. Refer to *Calibrate Zeros*. Once the Calibrate Zeros is done, check to see if the reading discrepancy still exists. If it does, continue.
- Connect a known, calibrated current clamp to a known, calibrated digital multimeter (DMM) and place the clamp on an input feed wire.
- Connect a load bank to the CCR.
- Put the CCR into Local mode.
- Navigate to the following menu, but do not enter the "Input Current" screen yet:
Configuration Menu > CCR Config > Calibrate > Input Current
- The LOCAL Up and LOCAL Down arrows will still operate while in the menu, allowing for easier calibration. Put the CCR on the lowest brightness step.
- Once the CCR is on the lowest brightness step, push the left DOT button to enter the "Input Current" screen.
- Check the DMM-measured current value. Use the UP and DOWN arrows below the screen to adjust the calibration value. Once the values match, push the left DOT button to accept.
- Put the CCR on the highest brightness step, while staying in the calibration menu.
- Check the DMM-measured current value. Use the UP and DOWN arrows below the screen to adjust the calibration value. Once the values match, push the left DOT button to accept.
- Cycle through the brightness steps, and verify the new calibration with the DMM. If the calibration is now acceptable, push the right DOT button until you're asked to Record Changes, to which you need to execute Yes.

- If the calibration needs additional fine-tuning, complete the calibration procedure again.
- If the calibration procedure does not yield acceptable results, you may want to restore a known good calibration. Refer to *Restoring a Known Good Calibration* for more information.

Calibrating Input Voltage

Before continuing, refer to *How to Determine if Recalibration is Needed*. If it is determined that recalibration is required, complete the following steps fully to ensure the most accurate results. Read all steps before beginning. Contact Airport Lighting Company for additional information as needed.

Note: a resistor load bank, such as can be provided by Airport Lighting Company, is recommended provide a purely-resistive load to the CCR during calibration. Ideally, the CCR should be loaded at 100% of its kW rating for the most accurate calibration.

- Before doing a full recalibration, complete a “Calibrate Zeros” of the CCR. Refer to *Calibrate Zeros*. Once the Calibrate Zeros is done, check to see if the reading discrepancy still exists. If it does, continue.
- Connect a load bank to the CCR.
- Put the CCR into Local mode.
- Open the CCR door and pull the door switch plunger toward you laterally to bypass the safety interlock.
- Navigate to the following menu, but do not enter the “Input Voltage” screen yet:
Configuration Menu > CCR Config > Calibrate > Input Voltage
- The LOCAL Up and LOCAL Down arrows will still operate while in the menu, allowing for easier calibration. Put the CCR on the lowest brightness step.
- Once the CCR is on the lowest brightness step, push the left DOT button to enter the “Input Voltage” screen.
- Using voltage probes on a known, calibrated DMM, measure the input voltage. It may be measured at the contactor, at the power-side fuse block, or on the control transformer.
- Check the DMM-measured value. Use the UP and DOWN arrows below the screen to adjust the calibration value. Once the values match, push the left DOT button to accept.
- Put the CCR on the highest brightness step, while staying in the calibration menu.
- Check the DMM-measured value. Use the UP and DOWN arrows below the screen to adjust the calibration value. Once the values match, push the left DOT button to accept.
- Cycle through the brightness steps, and verify the new calibration with the DMM. If the calibration is now acceptable, push the right DOT button until you’re asked to Record Changes, to which you need to execute Yes.
- If the calibration needs additional fine-tuning, complete the calibration procedure again.
- If the calibration procedure does not yield acceptable results, you may want to restore a known good calibration. Refer to *Restoring a Known Good Calibration* for more information.



Preventative Maintenance

Preventative Maintenance schedules and procedures for Constant Current Regulators are outlined in FAA Advisory Circular 150/5340-26, Section 5.2.

Airport Lighting Company recommends the following lists are used to accompany the procedures detailed in AC 150/5340-26.

Monthly CCR PM Task List

- Complete an exterior visual inspection of the CCR. Look for blockage of the vents on the front door, the top of the enclosure, and the back of the enclosure.
- General housekeeping; wipe down the CCR as needed to prevent dust buildup.
- In Local mode: cycle through the brightness steps and complete a visual inspection of circuit fixtures to ensure correct operation.
- With CCR power disconnected: complete an interior visual inspection. Look for blockages of the vents on the front door, as well as the top and rear of the enclosure.
- If large amounts of dust are present, consider using electronics compressed-gas duster to blow out dust from CCR components. Vacuum / wipe up any dust.
- Complete a visual inspection of airfield circuit terminations and supply feed lines. Look for loose wires, terminal or wire degradation, etc.

Yearly CCR PM Task List

- Complete an exterior visual inspection of the CCR. Look for blockage of the vents on the front door, the top of the enclosure, and the back of the enclosure.
- General housekeeping; wipe down the CCR as needed to prevent dust buildup.
- In Local mode: cycle through the brightness steps and complete a visual inspection of circuit fixtures to ensure correct operation.
- Verify the correct calibration of the CCR. Refer to *How to Determine if Recalibration is Needed* for more information.
- Verify the calibration of the IRMS / Megger, if equipped. To recalibrate, refer to *IRMS / Megger Calibration*.
- With CCR power disconnected: complete an interior visual inspection. Look for blockages of the vents on the front door, as well as the top and rear of the enclosure.
- Use electronics compressed-gas duster to blow out dust from CCR components. Vacuum / wipe up any dust.
- Complete a thorough inspection of airfield terminations and supply feed lines. Look for loose wires, terminal or wire degradation, etc. Verify that all connections pass a "tug test", output connection bolts are tight, and connection lugs are tight.



A, a – Ampere
AC – Alternating Current (power), Advisory Circular (standards)
ALC – Airport Lighting Company
BCD – Binary Coded Decimal
C – Celsius
CCR – Constant Current Regulator
CS – Current Sensor
CSS – Circuit Selector Switch
CT – Current Transformer
DC – Direct Current
DCMU – Digital Control & Monitoring Unit
DMM – Digital multimeter
FAA – Federal Aviation Administration
FLA – Full Load Amperage
FR – Ferroresonant
Hz – Hertz
IRMS – Insulation Resistance Monitoring System
kv – kilovolt
kW – kilowatt
LED – Light Emitting Diode
LO – Lamp Out
PF – Power Factor
PLC – Programmable Logic Controller
PM – Preventative Maintenance
SSR – Solid State Relay
V, v – Voltage
VA – Volt Amp
VAC, vac – AC Voltage
VDC, vdc – DC Voltage
W – Watt
Xfmr – Transformer

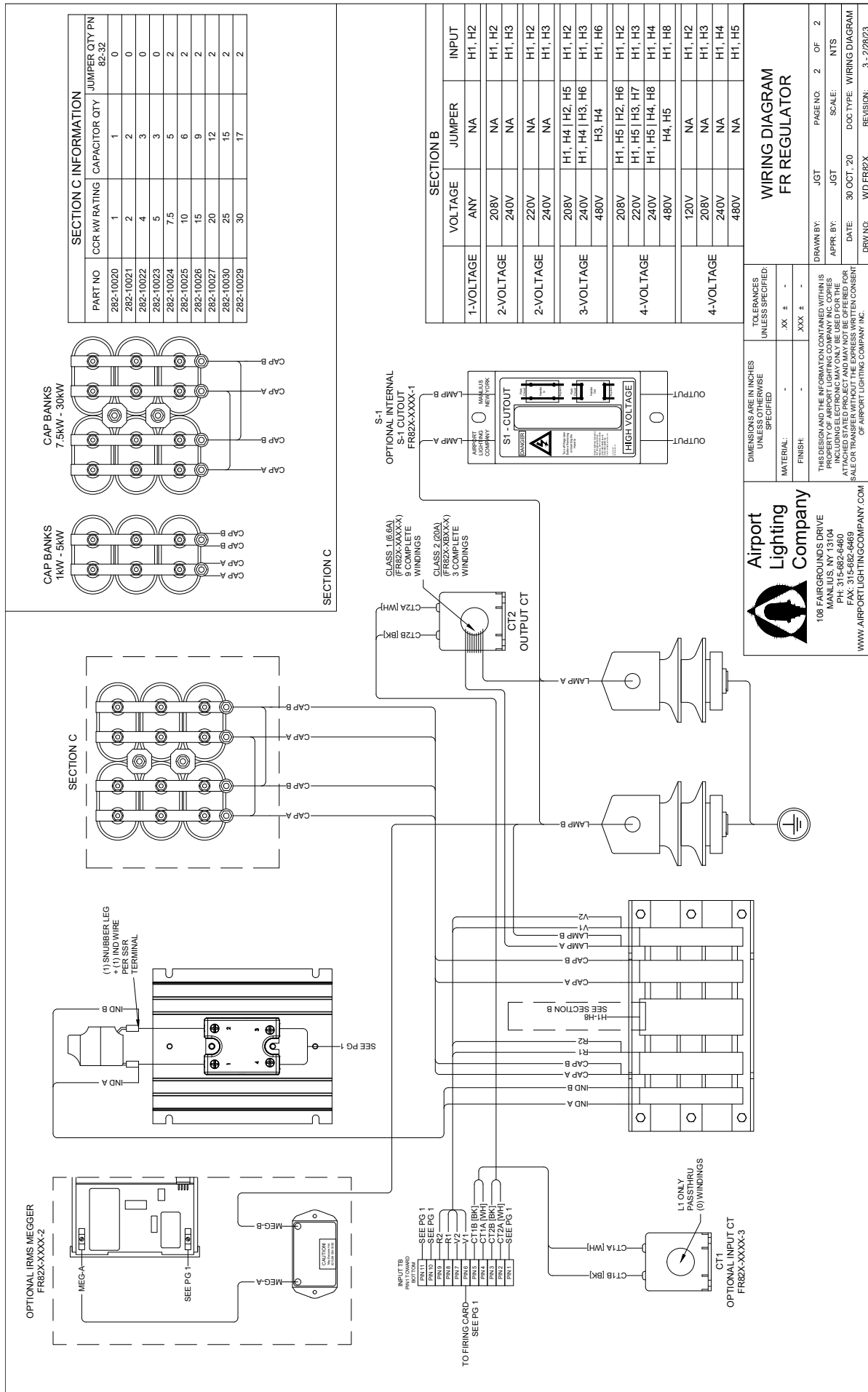

WIRING DIAGRAM
FR REGULATOR

DIMENSIONS ARE IN INCHES UNLESS OTHERWISE SPECIFIED

MATERIAL: .XX ± .XXX ±

FINISH: .XXX ±

THE PERSON AND THE INFORMATION CONTAINED HEREIN IS THE PROPERTY OF AIRPORT LIGHTING COMPANY, INC. COPIES INCLUDING ELECTRONIC MAY ONLY BE USED FOR THE ATTACHED STATED PROJECT AND MAY NOT BE OFFERED FOR SALE OR TRADING AT ANY OTHER CONSENT OF AIRPORT LIGHTING COMPANY, INC.

WWW.AIRPORTLIGHTINGCOMPANY.COM

Airport Lighting Company

108 FAIRGROUNDS DRIVE
MANLIUS, NY 13104
PH: 315-682-6460
FAX: 315-682-6469

DRAWN BY: JGT PAGE NO. 2 OF 2
APPR BY: JGT SCALE: NTS
DATE: 30 OCT, '20 DOC TYPE: WIRING DIAGRAM
DRW NO: WID FR82X REVISION: 3-228/23

COMPONENT PANEL LAYOUT DIAGRAM



Attached are the layout diagrams for both small cabinet CCRs (1kW through 10kW) as well as large cabinet CCRs (15kW through 30kW).
For tabloid-sized copies of the panel diagrams, contact Airport Lighting Company.

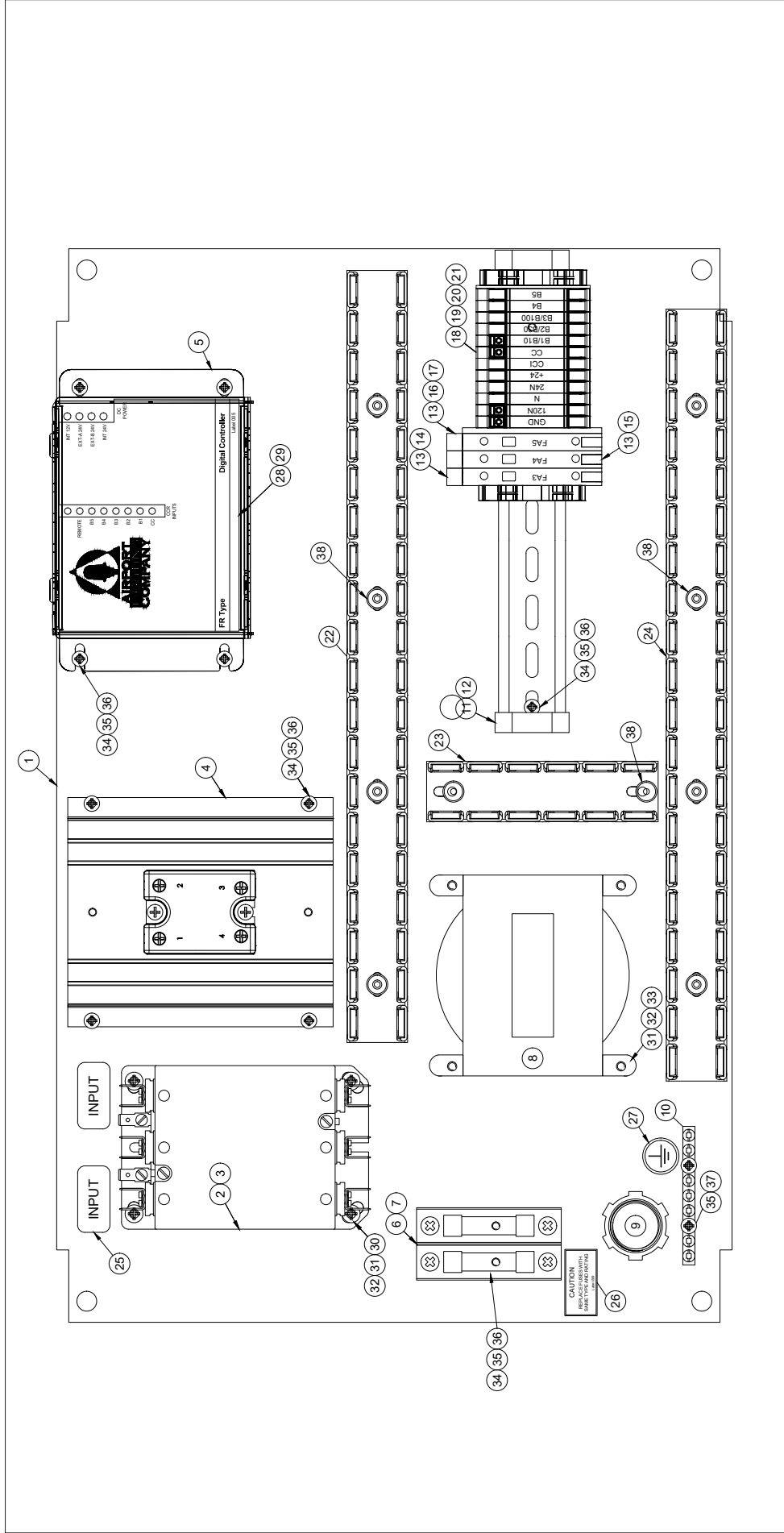

108 FAIRGROUNDS DRIVE
MANLIUS, NY 13104
PH: 315-682-6480
FAX: 315-682-6480
WWW.AIRPORTLIGHTINGCOMPANY.COM

SMALL COMPONENT PANEL
1KW - 10KW

TOLERANCES UNLESS OTHERWISE SPECIFIED:
MATERIAL: - XX ± -
FINISH: - XXX ± -

THIS DESIGN AND THE INFORMATION CONTAINED WITHIN IS PROPERTY OF AIRPORT LIGHTING COMPANY INC. COPIES OF THIS DESIGN AND INFORMATION ARE NOT TO BE REPRODUCED OR USED FOR ANY OTHER PROJECT WITHOUT THE EXPRESS WRITTEN CONSENT OF AIRPORT LIGHTING COMPANY INC.

DRAWN BY: JGT	PAGE NO: 1	OF: 2
APPR BY: JGT	SCALE: 1:2	
DATE: 24 MAR 20	DOC TYPE: ASSTY DIAGRAM	
DRW NO: 282-10010	REVISION: 2	- 2/28/23

Small CCR Component Panel Layout Diagram

COMPONENT PANEL LAYOUT DIAGRAM

BILL OF MATERIALS			
ITEM	PART NO	DESCRIPTION	QTY
1	82-16	Small Component Panel	1
2	82-97	Contactors, Square D, 75A	1
3	282-10005	Contactors MOV	1
4	290-280A01	SSR/Heatsink Assy, 50A	1
5	DCMU	REFER TO FINAL ASSY WT	1
6	55-00148	Fuse Block	1
7	82-88	Fuse, 5A MOL	2
8	82-89	Control Transformer	1
9	82-186	Input Surge Arrestor Assy	1
10	82-90	Ground Bar	1
11	82-63	DIN Rail, 15mm, 10" Lg	1
12	82-64	DIN Rail Cap, 35mmx15mm	2
13	90-EDW010	DIN Mount Fuse Block	3
14	82-76	Fuse, 5A Glass 1-1/4" x 1/4"	1
15	82-77	Fuse, 2.5 Glass 1-1/4" x 1/4"	1
16	82-78	Fuse, 1A Glass 1-1/4" x 1/4"	1
17	90-EDW011	DIN Mount Fuse Block End Cap	1
18	90-EDW006	Terminal Block	12
19	90-EDWA02	Terminal Block Jumper, 2P	2
20	90-EDW008	Terminal Block End Plate	1
21	90-EDW012	Screwless End Stop	2
22	82-115T	17" Wire Way	1
23	82-116	4-3/4" Wire Way	1
24	82-115B	17" Wire Way	1
25	82-402	Input Label	2
26	82-409	Caution-Replace Fuses Label	1
27	82-404	Ground Label	1
28	82-405	DCMU Label	1
29	82-407	Sales and Service Label	1
30	99-00170	10-32 x 3/4" Phil Pan Screw, SS	4
31	99-00042	#10 Split Lock Washer, SS	8
32	99-00044	#10 Flat Washer, SS	8
33	99-00146	10-32 x 1/2" Phil Pan Screw, SS	4
34	55-00156	#8-32 x 3/8 Phil Pan Head Screw, SS	10
35	99-00103	#8 Split Lock Washer, SS	18
36	99-00105	#8 Flat Washer, SS	16
37	99-00145	#8-32 x 3/4" Phil Pan Head Screw, SS	2
38	82-114	Nylon Rivet	10

Firing Card Options	
PART NO	DESCRIPTION
290-280A05	FIRING CARD ASSY
290-280A06	FIRING CARD W MEGGER ASSY

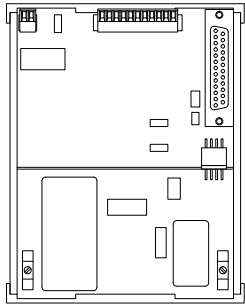
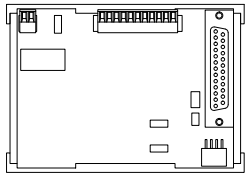

Airport Lighting Company
108 FAIRGROUNDS DRIVE
MANLIUS, NY 13104
TEL: 315-682-6460
FAX: 315-682-6489
WWW.AIRPORTLIGHTINGCOMPANY.COM

DIMENSIONS ARE IN INCHES UNLESS OTHERWISE SPECIFIED
MATERIAL: - XX ± -
FINISH: - XXX ± -

TOLERANCES UNLESS SPECIFIED:
XX ± -
XXX ± -

THIS DESIGN AND THE INFORMATION CONTAINED WITHIN IS THE PROPERTY OF AIRPORT LIGHTING COMPANY. NO PARTS INCLUDING ELECTRONIC MAY ONLY BE USED FOR THE ATTACHED STATED PROJECT AND MAY NOT BE OFFERED FOR SALE OR THE REUSE OF THE INFORMATION WITHOUT THE CONSENT OF AIRPORT LIGHTING COMPANY INC.

SMALL COMPONENT PANEL
1KW - 10KW

DRAWN BY: JGT PAGE NO: 2 OF 2
APPR. BY: JGT SCALE: 1:2
DATE: 24 MAR 20 DOC TYPE: ASSY DIAGRAM
DRW NO: 282-10010 REVISION: 2 - 2/28/23

Small CCR Component Panel Layout Diagram

COMPONENT PANEL LAYOUT DIAGRAM

ITEM	PART NO	DESCRIPTION	QTY
1	82-31	Large Component Panel	1
2		Contactor, Reference Table	1
3	282-10005	Contactor MOV	1
4		SSR/Heatsink Assy, Reference Table	1
5	82-60	Digital Control Monitoring Unit (DCMU)	1
6	55-00148	Fuse Block	1
7	82-88	Fuse, 5A MOL	2
8	82-89	Control Transformer	1
9	82-186	Input Surge Arrestor Assy	1
10	82-90	Ground Bar	1
11	82-63	DIN Rail, 15mm, 10" Lg	1
12	82-64	DIN Rail Cap, 35mmx15mm	2
13	82-66	DIN Mount Fuse Block	3
14	82-76	Fuse, 5A Glass 1-1/4" x 1/4"	1
15	82-77	Fuse, 2.5 Glass 1-1/4" x 1/4"	1
16	82-78	Fuse, 1A Glass 1-1/4" x 1/4"	1
17	82-69	DIN Mount Fuse Block End Cap	1
18	82-65	Terminal Block	12
19	82-66	Terminal Block Jumper, Screw	2
20	82-67	Terminal Block End Plate	1
21	82-71	End Stop	2
22	82-118	10" Wire Way	1
23	82-119	8" Wire Way	1
24	82-116	26.5" Wire Way	1
25	82-402	Input Label	2
26	82-409	Caution-Replace Fuses Label	1
27	82-404	Ground Label	1
28	82-405	DCMU Label	1
29	82-407	Sales and Service Label	1
30		Contactor Mounting Hardware, Reference Table	1
31	99-00042	#10 Split Lock Washer, SS	4
32	99-00044	#10 Flat Washer, SS	4
33	99-00146	10-32 x 1/2" Phil Pan Screw, SS	4
34	55-00156	#6-32 x 3/8" Phil Pan Head Screw, SS	10
35	99-00103	#6 Split Lock Washer, SS	12
36	99-00105	#6 Flat Washer, SS	10
37	99-00145	#6-32 x 3/4" Phil Pan Head Screw, SS	2
38	82-114	Nylon Rivet	11
39		SSR/Heatsink Mounting Hardware, Reference Table	1

CONTACTOR DETAILS

CCR KW RATING	PART NO	DESCRIPTION	MOUNT SCREW	MOUNT LOCK WASHER	MOUNT FLAT WASHER	MOUNT HARDWARE QTY/EACH
15KW	82-98	CONTACTOR, SQUARE D, 95A	10-32 x 3/4" Phil Pan Screw, SS	#10 Split Lock Washer, SS	#10 Flat Washer, SS	4
20KW	82-99	CONTACTOR, SQUARE D, T15A	1/4-20 x 1" Hex Screw, SS	99-00032	99-00034	4
25KW	82-100	CONTACTOR, SQUARE D, 150A	1/4-20 x 1" Hex Screw, SS	99-00032	99-00034	4
30KW	82-101	CONTACTOR, SQUARE D, 185A	1/4-20 x 1" Hex Screw, SS	99-00032	99-00034	6

SSR/HEATSINK DETAILS

CCR KW RATING	PART NO	DESCRIPTION	MOUNT SCREW	MOUNT LOCK WASHER	MOUNT FLAT WASHER	MOUNT HARDWARE QTY/EACH
15KW	290-280A02	SSR/HEATSINK ASSY, 125A SM	8-32 x 3/8" Phil Pan Screw, SS	#6 Split Lock Washer, SS	#6 Flat Washer, SS	4
20KW	290-280A03	SSR/HEATSINK ASSY, 125A LG	8-32 x 3/8" Phil Pan Screw, SS	#6 Split Lock Washer, SS	#6 Flat Washer, SS	6
25KW	290-280A03	SSR/HEATSINK ASSY, 125A LG	8-32 x 3/8" Phil Pan Screw, SS	#6 Split Lock Washer, SS	#6 Flat Washer, SS	6
30KW	290-280A03	SSR/HEATSINK ASSY, 125A LG	8-32 x 3/8" Phil Pan Screw, SS	#6 Split Lock Washer, SS	#6 Flat Washer, SS	6

Firing Card Options

PART NO	DESCRIPTION
290-280A05	FRING CARD ASSY
290-280A06	FRING CARD W/MEGGER ASSY

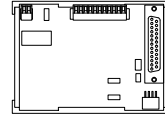

290-280A05

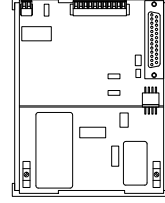

290-280A06



Airport Lighting Company
108 FAIRGROUNDS DRIVE
MANLIUS, NY 13104
PHONE: 315-682-6460
FAX: 315-682-6489
WWW.AIRPORTLIGHTINGCOMPANY.COM

DIMENSIONS ARE IN INCHES UNLESS OTHERWISE SPECIFIED
MATERIAL: -
FINISH: -

THIS DESIGN AND THE INFORMATION CONTAINED WITHIN IS THE PROPERTY OF AIRPORT LIGHTING COMPANY. NO PARTS INCLUDING ELECTRONIC MAY ONLY BE USED FOR THE ATTACHED'S STATED PROJECT AND MAY NOT BE OFFERED FOR SALE OR THE REPRODUCTION OF ANY PART THEREOF WITHOUT THE WRITTEN CONSENT OF AIRPORT LIGHTING COMPANY INC.

UNIVERSAL LARGE COMPONENT PANEL
15KW - 30KW

DRAWN BY: JGT PAGE NO: 2 OF 2
APPR. BY: JGT SCALE: 1:3
DATE: 24 MAR '20 DOC TYPE: ASSY DIAGRAM
DRW NO: 262-10015 REVISION: 1 - 2/28/23

Large CCR Component Panel Layout Diagram



CCR Menu Navigation Flowchart

The included flowchart is designed to accompany a user when navigating the CCR menus. For information about accessing and using the menu, refer to *How to Navigate the CCR Display and Keypad* and *CCR Configuration*.

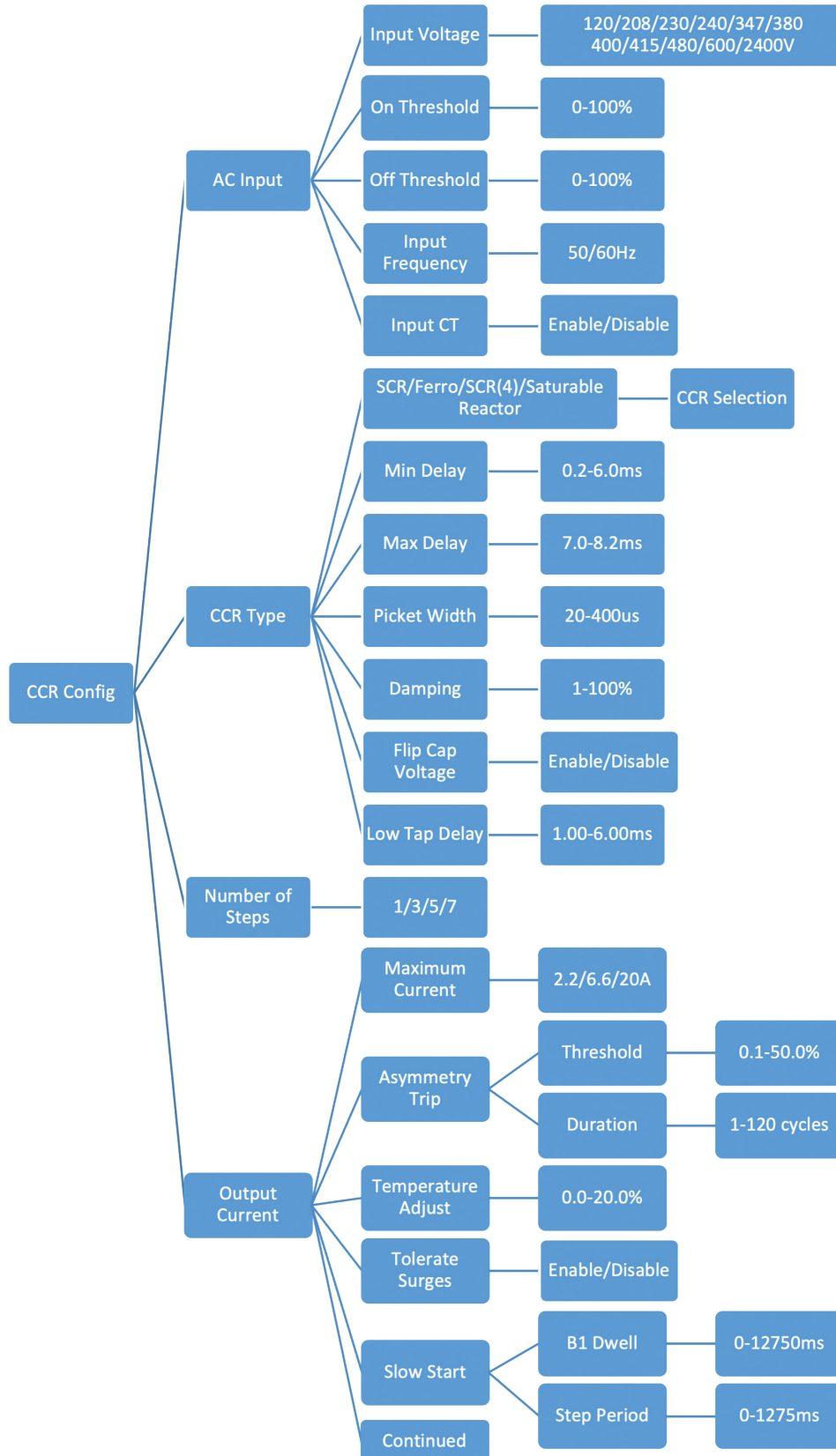

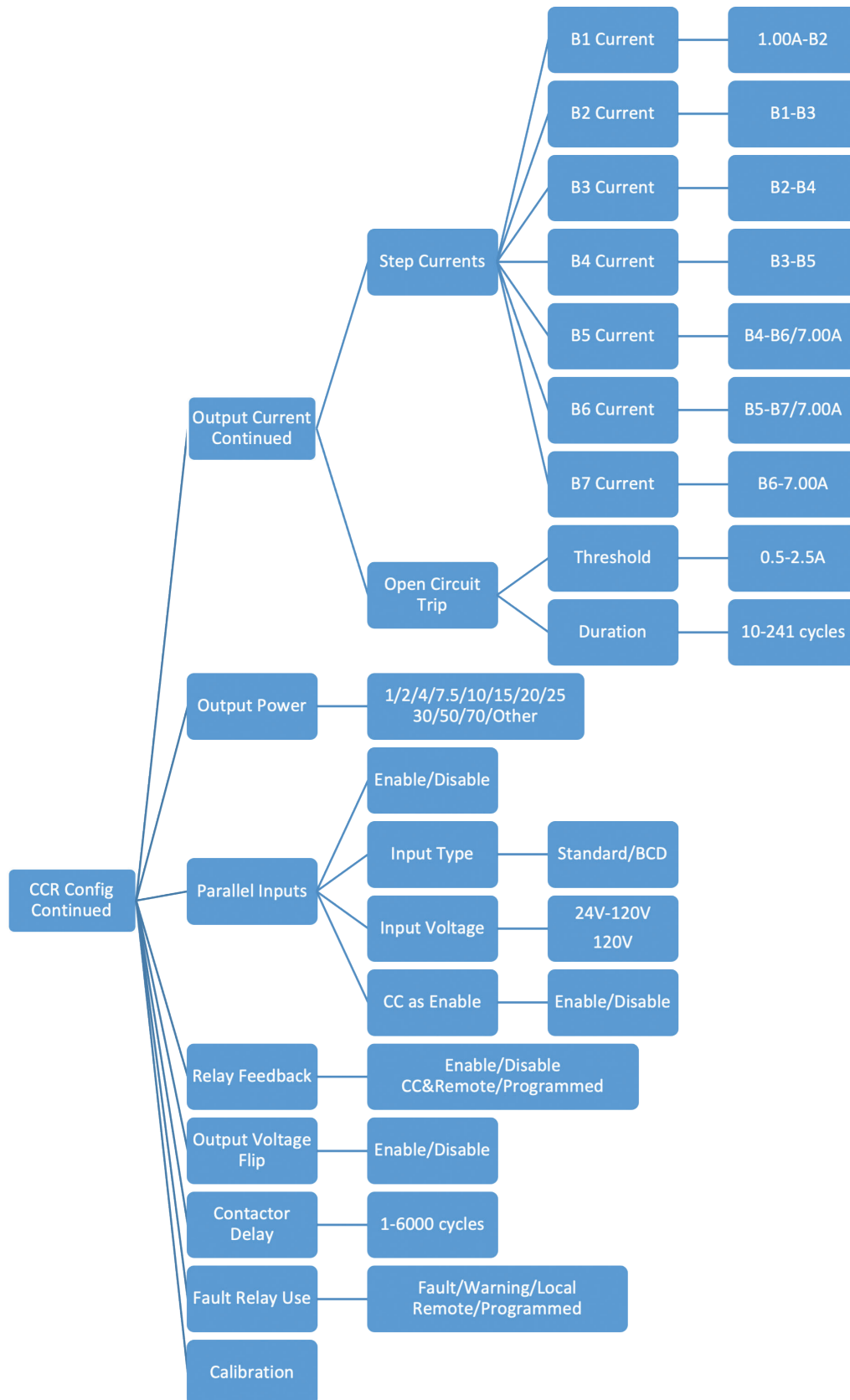

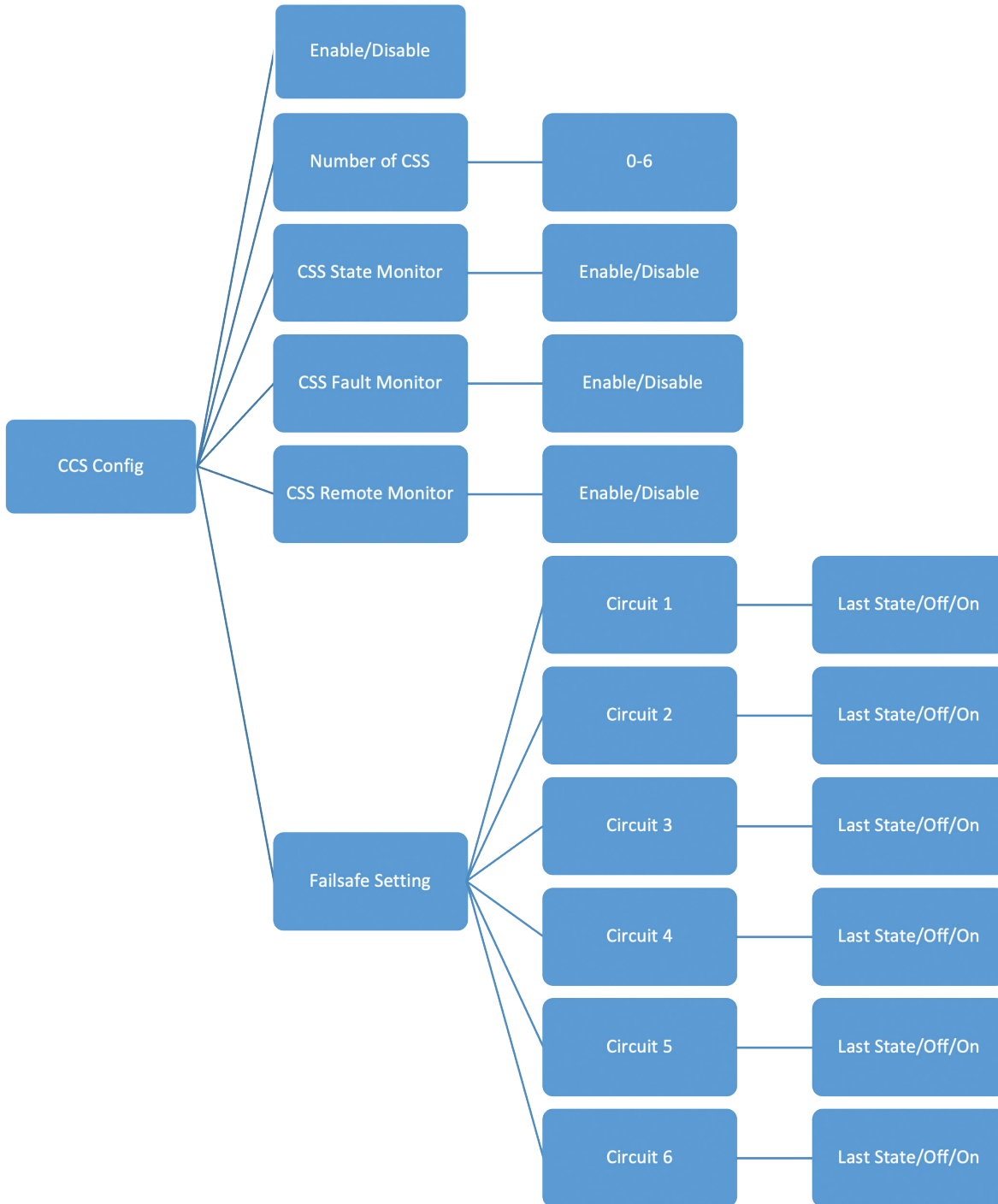

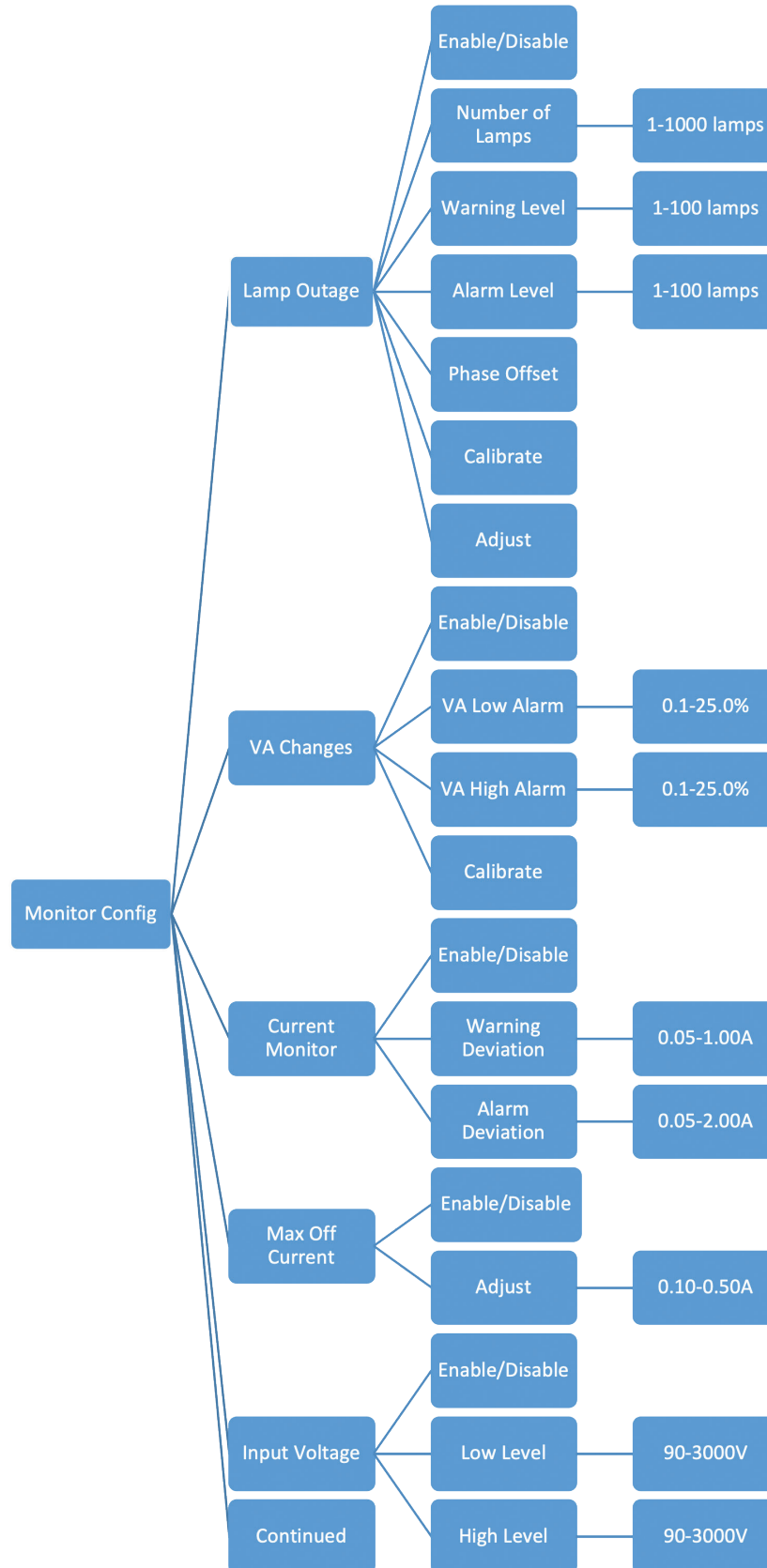

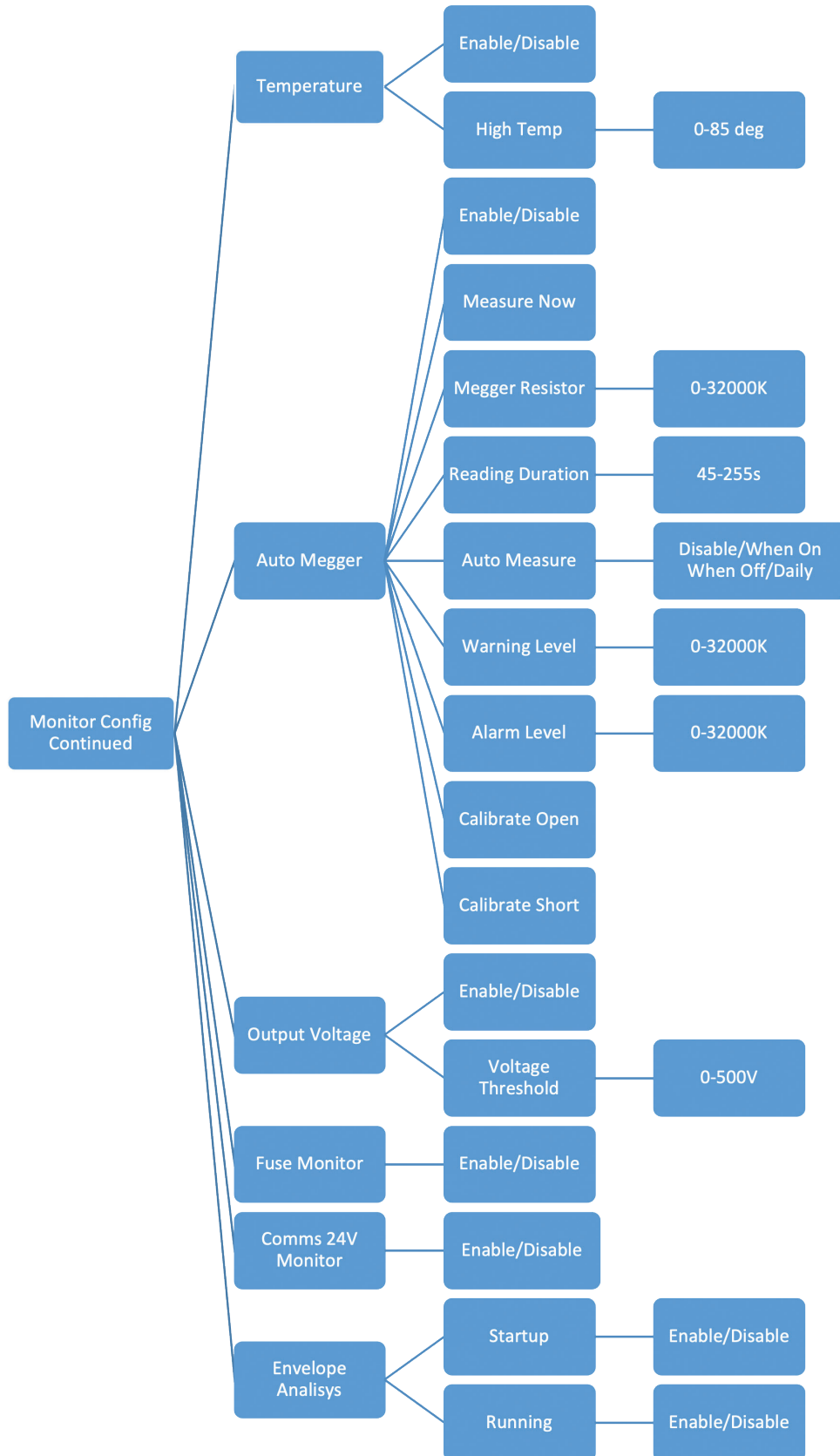

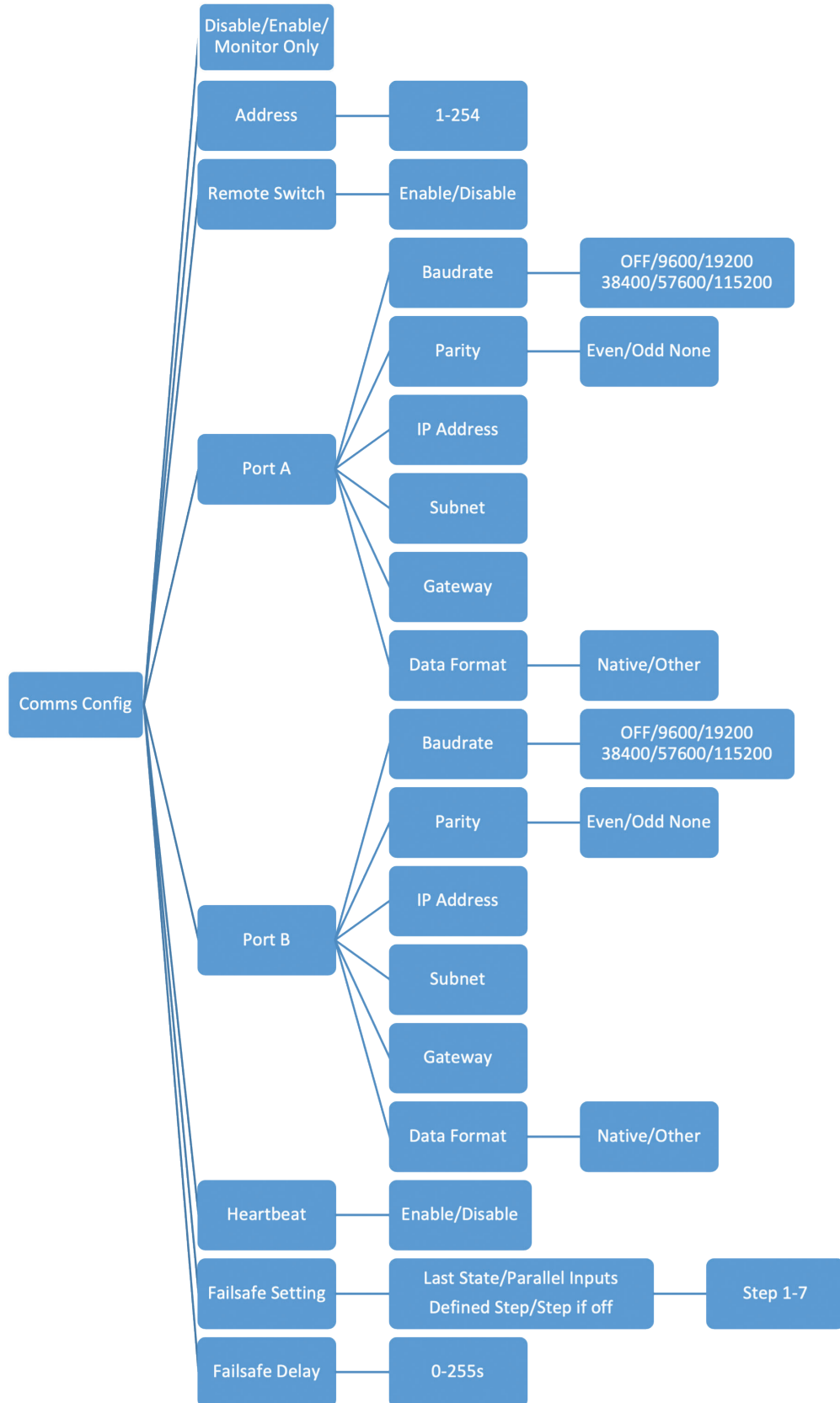

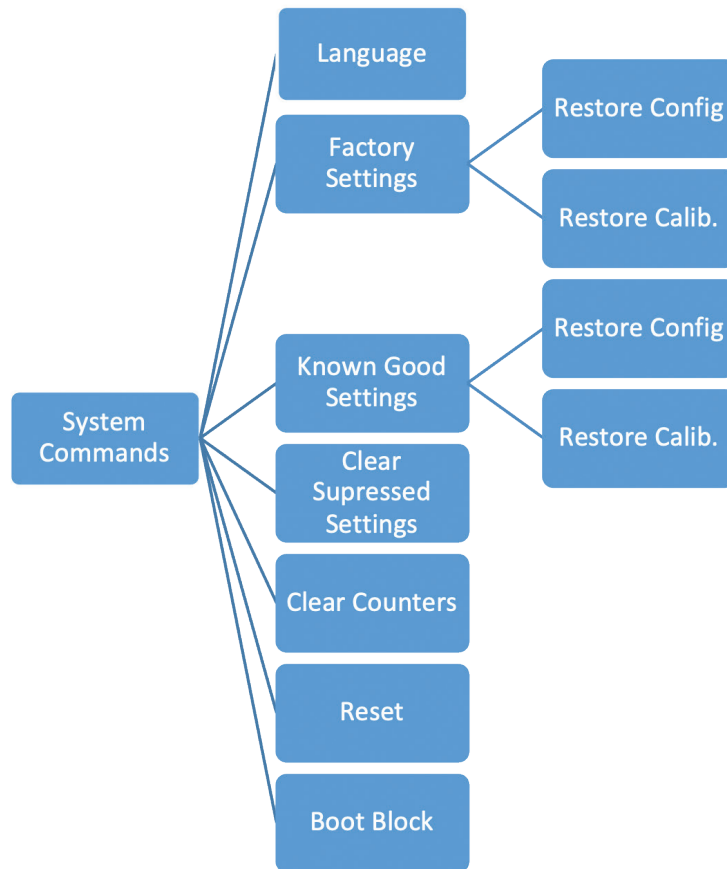



REPLACEMENT PARTS



Airport Lighting Company

An ISO 9001:2015 Certified Company

It is recommended to have an on-hand supply of replacement parts to ensure unanticipated downtime is minimal. Please refer to the following table for Airport Lighting Company part numbers and description of common replacement parts. A DCMU requires regulator-specific programming prior to installation. Please provide the Catalog Number(s) &/or Serial Number(s) of the regulator(s) you are purchasing a DCMU for at time of order. For clarification or assistance ensuring the correct replacement part is ordered and installed, please contact Airport Lighting Company.

Quantity	Part Number	Description	Information
2	82-88	5A Fuse for FA1, FA2	10mm x 38mm Fast-Acting
1	82-76	5A Fuse for FA3	Glass ¼ x 1-¼, Fast-Acting
1	82-77	2.5A Fuse for FA4	Glass ¼ x 1-¼, Fast-Acting
1	82-78	1A Fuse for FA5	Glass ¼ x 1-¼, Fast-Acting
1	290-28D1003	DCMU Controller, 8 Input, Standard	WBC-9100-03
1	290-28D0102	DCMU Controller, 8 Input, COMM Option A	WBC-9101-02
1	290-28D0202	DCMU Controller, 8 Input, COMM Option B	WBC-9102-02
1	290-28D0303	DCMU Controller, 8 Input, COMM Option C	WBC-9103-03
1	290-28D0403	DCMU Controller, 8 Input, COMM Option D	WBC-9104-03
1	290-280A05 or 290-280A06	Firing Card Assembly Firing Card with Megger Assembly	
1	282-10030	Front Panel Display Assembly	
1	82-45	Display Cable	WBC-900
1	55-00201	Door Switch/Safety Interlock	ZF SPDT w/ Pull-to-Defeat
1	282-10005	Contactor MOV Assembly	
1	282-10002	Snubber Assembly	
1	290-280A01	SSR/Heatsink, 1kW to 10kW	
1	290-280A02	SSR/Heatsink, 15kW to 30kW	
1	282-10036	15kW Contactor/SSR Kit	
1	282-10037	20kW Contactor/SSR Kit	
1	282-10034	25kW Contactor/SSR Kit	
1	282-10039	30kW Contactor/SSR Kit	

Table 9: Replacement Parts

IEC Monitoring

The Airport Lighting Company FR CCR product line is tested to and complies with FAA Advisory Circular 150/5345-10 (Current Edition) for both L828 and built-in L829 functionality. The built-in L829 functionality includes L827 circuit-status and CCR-status monitoring.

In addition to the compliances to the FAA Advisory Circular, the FR CCR has options to meet other monitoring standards. This addendum is to address some outputs for monitoring addressed in IEC 61822 Ed. 2.

To accomplish IEC Monitoring, the DCMU within the FR CCR has a 10-bit output card. The output card itself, as well as the connecting terminal block, have 13 connections. Position number one is the position closest to the “back” of the DCMU, where it meets the component mounting panel. Position thirteen is the position closest to the front face of the DCMU.

Position	IEC Monitoring ID	DCMU Output LED	Description
1	n/a	n/a	COM
2	n/a	n/a	Relay Common (Up to 120VAC/VDC)
3	n/a	n/a	+24V
4	I	Out 1	Open Circuit Trip
5	J	Out 2	Over Current Trip
6	B	Out 3	Local/Remote
7	A	Out 4	CCR On (Contactor Closed)
8	M & N	Out 5	Lamp Fault Warning & Lamp Fault Alarm
9	O & P	Out 6	Earth Fault Warning & Earth Fault Alarm (IRMS)
10	n/a	Out 7	XCP Monitor (External Control Voltage Within Range)
11	C1	Out 8	Step B10 Obtained
12	D1	Out 9	Step B30 Obtained
13	E1	Out 10	Step B100 Obtained

To use the output card in the DCMU, a voltage source or sink must be present on position 2, up to 120VAC. It is generally recommended that a source is used. The source on position 2 will be distributed to each of the outputs (Out 1 – Out 10, positions 4 – 13) as the monitor status changes.

To ensure a safe setup, ensure all neutrals and commons are not mixed with different voltage sources.