

# L-801 HBM 150/2 Airport Rotating Beacon



Beacon Tipdown Pole

## Compliances

Certified to FAA L-801 AC 150/5345-12 (Current Edition) and ICAO Annex 14, para 5.3.3



## Application

This Hali-Brite beacon is designed for night operation as an identification and location marker for airports

## Key Features

- Patented belt-drive system eliminates the lubrication required by conventional gear-drive beacons (U.S. Pat. 5,339,224)
- Patented liquid-filled lamp connector, eliminating the slip rings and brushes found on conventional beacons (U.S. Pat. 5,816,678)
- Two 13,000 lumen, 150 watt pulse-start metal-halide lamps
- 10,000 hour typical lamp life (2-3 years)
- One clear lens, one aviation green lens
- No maintenance except lamp replacement
- All moving parts are permanently lubricated
- Impedance-protected motor eliminates burnouts
- Lamps preset 5° above horizontal, adjustable
- 12 RPM rotation, 24 flashes/minute
- Weatherproof steel cabinet, powder coated international orange
- Class I temperature range: -30 to +55 °C (-22 to +131 °F)
- Class II temperature range: -55 to +55 °C (-67 to +131 °F)
- Tested to wind velocities of 100 mph
- Optional photocell and/or tell-tale relay
- Mountable on a Hali-Brite Tipdown Pole
- Power Consumption: 395W Class I, 795W Class II
- Manufactured in the USA

# Specifications

## Ordering Information

Part Number	Description
L801A1116	120 VAC, 60 Hz, Class I
L801A1125	220-240 VAC, 50 Hz, Class I
L801A1126	220-240 VAC, 60 Hz, Class I
L801A1216	120 VAC, 60 Hz, Class II
L801A1225	220-240 VAC, 50 Hz, Class II
L801A1226	220-240 VAC, 60 Hz, Class II

Note: 220-240 VAC must be single wire with neutral

## Options

Part Number	Description
L-801/802 T/T HBM 120	Tell-tale Relay, 120 VAC
L-801/802 T/T HBM 240	Tell-tale Relay, 220-240 VAC
4200-0000	Tower Mounting Kit
L801-/L802 HBM SS	Stainless Steel Option

## Replacement Parts

Part Number	Description
0200-0024	Ballast Assy 50 Hz
0200-0023	Ballast Assy 60 Hz
0600-0003	Belt
2300-0002	Motor Fuse, 1/2 amp
2300-0010	Lamp Fuse, 6.25 amp
3400-0125B	Lamp, 150 watt pulse-start
2800-0006	Lens, Clear
2800-0043	Lens, Green
2800-0025	Lens, Amber
1500-0011	Lens Clip

## Standard Options Available

- Unpacked Weight: 75 pounds
- USA Shipping Weight: 110 pounds
- USA Shipping Volume: 48" x 25" x 25"
- International Shipping Weight: 110 pounds
- International Shipping Volume: 40" x 25" x 25"

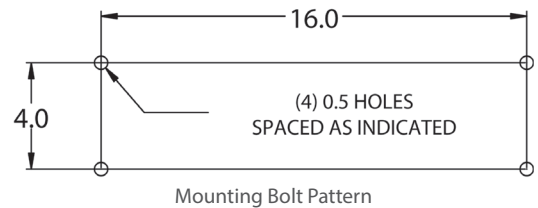
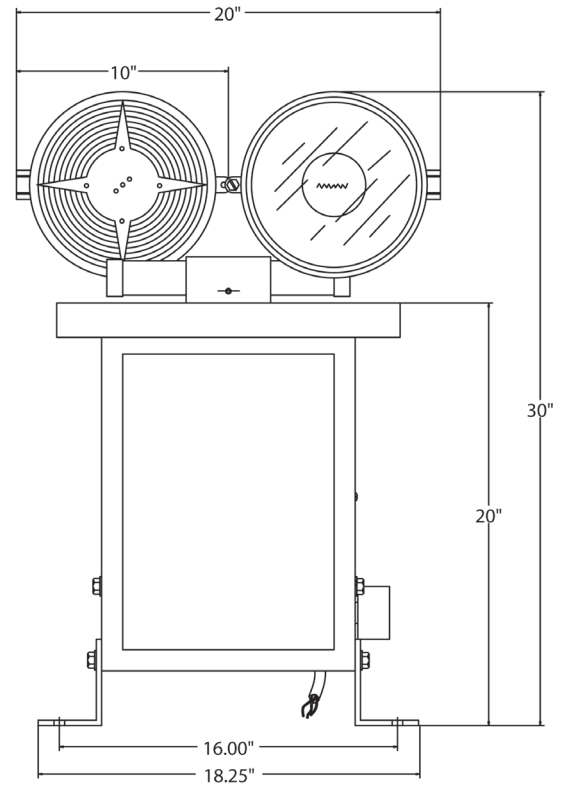

## Effective Intensity vs. Elevation (White Lens)

