

Airfield Lightning Arrestor



Compliances

Complies with AC 150/5345-10 Current Edition. Section 3.4.12 Lightning/Surge Arrestors

Application

The ALA can be deployed at various locations in the 5kV primary series circuit to help reduce the susceptibility of airfield circuits to lightning strikes or surges.

Key Features

- Compatible with all types of L-828/L-829 CCRs, incandescent and LED light fixtures and isolation transformers operating on 6.6A or 20A series circuits.
- Designed for operation at 5000V, the ALA is suitable for any airfield series circuit up to 30KW at 6.6A, and up to 70KW at 20A.
- Rated IP68 (NEMA 6P), suitable for installation in below ground base cans, handholes and manholes, or by direct burial.
- Connection to the primary circuit uses an L-823 male/female "T" connector(s) to ensure the primary circuit remains intact upon a failure of the ALA.
- A 3/8"-16 stainless steel stud provides solid ground connection for #6 AWG or larger ground wire.
- Compatible with Insulation Resistance Monitoring Systems (IRMS) and 500V to 5KV meggers.
- The ALA can be tested using a 5KV megger. Resistance from Line to Ground terminals should be greater than 2G ohm.

**General
Catalog
Numbers**

ALA-1

Specifications

Recommended Use

The ALA is designed to be installed in the 5KV primary series circuit. In order to offer the optimal circuit protection from possible lightning strikes or power surges it is suggested the ALA should be installed at the beginning of the circuit closest to the Constant Current Regulator (CCR). Additional ALA's should be added onto the circuit at intervals of 2,000 feet (600m). ALAs can be installed at closer intervals should the circuit be in an area that is highly susceptible to lightning strikes. Each ALA adds additional local protection against damage from lightning strikes reducing the risk of widespread damage in the field and to equipment in the electrical vault.

Dimensions

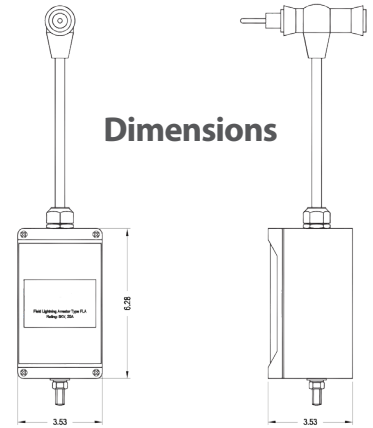

Connection

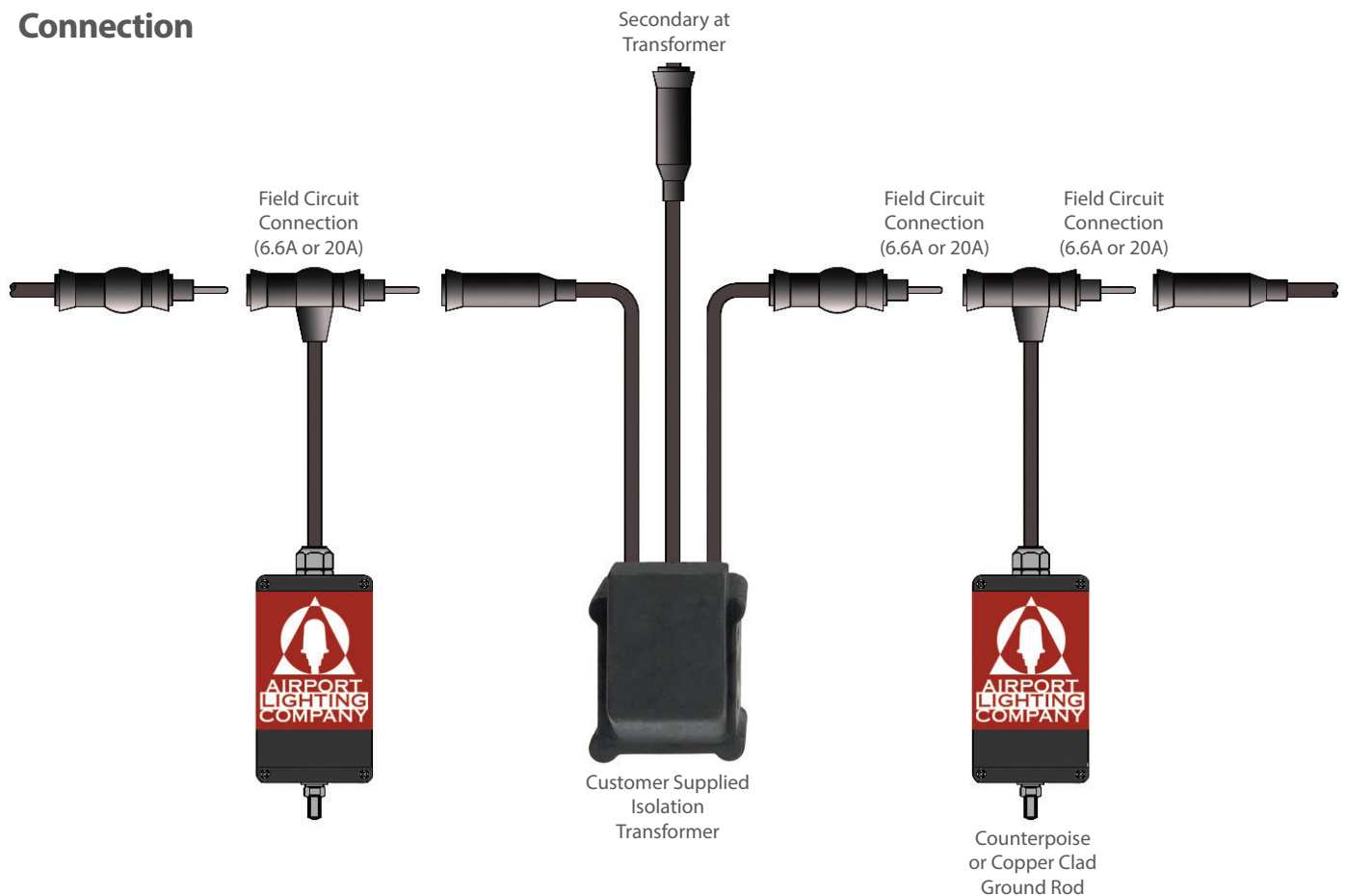

Specifications

Specifications

Nominal Voltage	6 KV
Continuous Operation Voltage	5.1 KV
Duty Cycle	10 kA crest (20 current surges) 40 kA crest (2 current surges) 8 / 20 us wave shape
High Current Discharge (Short Duration)	100 kA crest (2 current surges) 4 / 10 us wave shape
Low Current Discharge (Long Duration)	250A crest (20 current surges) 2000 us wave shape
Maximum Discharge Voltage	19.8KV Crest @ 10kA 24.7KV Crest @ 40kA 8 / 20 us wave shape
Protection Index	IP68 (NEMA 6P)
Operating Temperature	-40°C to +60°C
Weight	2 kg (4.4 lb)