

STROBE APPROACH LIGHTING TECHNOLOGY

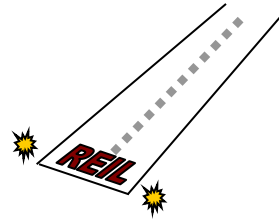

L-849V, STYLE A & E LED VOLTAGE-POWERED APPROACH LIGHTING SYSTEM

SAL-1030-V

USER'S MANUAL

MAN-AL07 Rev 1.2

STROBE APPROACH LIGHTING TECHNOLOGY™
108 Fairgrounds Drive, Manlius, NY, 13104
603-598-4100



SCOPE

This manual contains Installation, Operation, and Maintenance information for an LED-based L-849V, Styles A & E, Unidirectional Runway Approach Lighting system manufactured by Strobe Approach Lighting Technology™ (SAL Technology™) for use in constant-current powered applications. The manufacturer's designation for this equipment is SAL-1030-V REIL System.

CARTON LABELING

The SAL-1030-V REIL System consists of two Head Assemblies, two Junction Boxes, one Master Control Unit (MCU), and three (3) frangible couplings shipped in cartons with protective inserts.

UNPACKING

Inspect each shipping carton for external damage immediately upon receipt. There could be damage to the contents if the carton is damaged. Promptly file a claim with the freight carrier if you have received damaged equipment.

TOOLS RECOMMENDED

#2 Phillips screwdriver; 10-inch shank.
3/16-inch (5 mm), flat blade screwdriver; 10-inch shank.
Large (3-inch) slip-joint pliers (for pipe and lock nuts)
Wire strippers.
Wire cutters (for small gage wire).
Volt-Ohm meter

ABBREVIATIONS USED IN THIS MANUAL

MCU → Master Control Unit
J-B → Junction Box
OFH → Optical Flash Head
REIL → Runway End Identifier Lights
SLC → Series Lighting Circuit
NPT → National Pipe Tapered thread
NPS → National Pipe Straight thread (not tapered)
EMT → Electrical Metallic Tubing

DISCLAIMER

The information in this manual is believed to be accurate and up to date, however, Strobe Approach Lighting Technology assumes no liability for damages or injuries that may result from errors or omissions, or from the use of information presented herein. Strobe Approach Lighting Technology reserves the right to modify this manual at its own discretion without notification to any person or organization.

APPLICABLE SPECIFICATIONS

This equipment meets or exceeds the requirements in the FAA Advisory Circular, AC 150/5345-51B, and EB 67D.

WARRANTY

Strobe Approach Lighting Technology™ warrants this equipment and all of its components when used under normal conditions. Failure of any component within from the date of shipment will be corrected by repair or replacement, FOB Nashua, NH 03060.

USE OF GENERIC PARTS

Using parts not manufactured or supplied by Strobe Approach Technology™, or unauthorized modification of any part of this equipment, voids the warranty and could render the equipment noncompliant with applicable FAA specifications.

IMPROPER INSTALLATION

This equipment can be damaged if the procedures and recommendations contained herein are not observed during installation. Any damage resulting from incorrect installation will void warranty.

CONTACT INFORMATION

Strobe Approach Lighting Technology may be contacted by the following methods:

Tele: 603-598-4100

Email: sales@saltechnology.com

WARNING

Do Not Depend on Interlocks For Safety

Never depend on an interlock switch alone to render the equipment safe. Always turn off and lock out upstream power when performing maintenance on this equipment.

TABLE OF CONTENTS

	Page
Front Matter -----	i-iv
Carton Labeling-----	i
Unpacking -----	i
Tools Recommended-----	i
Abbreviations Used in This Manual -----	i
Applicable Specifications -----	i
Warranty-----	ii
Use of Generic Parts-----	ii
Contact Information -----	ii
Table of Contents -----	iii
List of Figures -----	iv
General Description -----	1
Equipment Specifications -----	2
Installation-----	3-9
Access-----	3
Master Control Unit-----	4
Optical Heads-----	5
Zeroing and aiming-----	6
Wiring-----	7-9
Remote Control-----	8
Functional Description -----	10
Theory of Operation-----	10
Operating Instructions-----	11-12
Troubleshooting-----	13-14
Maintenance-----	15
Replaceable Parts-----	16

LIST OF FIGURES

PAGE

1a: Power Supply -----	1
1b: Flash Head -----	1
1c: Co-mounted Unit-----	1
2: Master Control Unit-----	4
3: Optical Heads-----	5
4: Electrical Hookup Overview-----	7
5: MCU Input Terminal Block-----	7
6: Remote Control Wiring-----	8
7: Junction Box Wiring-----	9
8: Lightning Protection-----	9
9: Component Identification-----	16
A-1: External Wiring For SAL-1030-V-----	A-1
A-2: MCU Wiring Diagram-----	A-2

GENERAL DESCRIPTION

The SAL-1030-V is a voltage-powered REIL System consisting of two identical Light Units and a Master Control Unit (MCU). Each Light Unit is made up of an Optical Head and a Junction Box. The heads and Junction Boxes are separated for shipment and must be assembled mechanically and electrically during installation. Each Junction Box contains a 48 Vdc power supply and provides a convenient location for electrical connections without having to access the Optical Heads.

The MCU is in a separate enclosure that is electrically connected to the two Junction boxes by means of power wiring and an RS-485 data bus.

The SAL-1030-V has three flash intensity modes that may be selected by remote switching.



Fig. 1a
Optical Flash Head



Fig. 1b
Master Control Unit (MCU)



Fig. 1c
SAL 1030-V System
(Only one flash head shown)

EQUIPMENT SPECIFICATIONS

PHYSICAL: Dimensions are in inches (mm); Weight in lbs (kg).

Master Control Unit (Figure 1a).

Dimensions ----- 6.5H x 13.5W x 12D (165 x 343 x 305)
Weight: ----- 10.2 (4.6)

Optical Head (Figure 1b).

Dimensions ----- 15H x 15W x 4.8D (381 x 381 x 122)
Weight: ----- 24.6(11.2)
Height is overall-See Figure 3.

Junction Box (Figure 1c).

Dimensions: ----- 7.9 x 9.0W x 4.5D (201 x 229 x 114)
Weight: ----- 8.8 (4.0)

OPERATIONAL:

Voltage (rms) ----- 100 to 240 Volts, 50/60 Hz
Power: (Watts) ----- 50
Flashes Per Minute ----- 120
Intensity: (Effective Candelas*, total beam spread) High: 8000 to 22500
Med: 800 to 2250
Low: 160 to 450
Beam Spread: ----- 30° Horizontal, 10° Vertical.

AVAILABLE OPTIONS: (Must be factory installed)

Alarm function (dry relay contacts)
Remote control by current from a Series Lighting Circuit

*Measurement method according to AC 150/5345-51B. Para. 3.4.1c.

INSTALLATION

In this section you will find instructions and recommendations for:

- Emplacement preparations.
- Installation sequence.
- Accessing the various components of the system.
- Mounting the Master Control Unit (MCU).
- Mounting the Junction Boxes.
- Mounting the Optical Heads
- Zeroing the Horizontal Aiming Scale and Pointer.
- Zeroing the Vertical Scale and Pointer.
- Electrical connections.

EMPLACEMENT PREPARATIONS

The SAL 1030 LED REIL system requires three prepared emplacements: one for each Optical Head, and one for the Master Control Unit (MCU). Each emplacement requires a foundation with a 2-inch NPS or NPT female threaded receiver such as a flange bolted to a concrete pad, or an in-ground can cover with a threaded hole. Detailed drawings for the emplacement foundations are furnished by others.

The MCU can be installed at any convenient location and may be located several hundred feet from the nearest Optical Head. However it may alternatively be co-located with one of the optical heads, but separately supported.

RECOMMENDED INSTALLATION SEQUENCE (ABBREVIATED)

- Install the Junction Boxes at the prescribed light positions.
- Zero the Horizontal Scale at each light emplacement. The zero degree-angle is meant to be parallel to the centerline of the runway.
- Install each Optical Head onto its Junction Box with the Horizontal Pointer at the prescribed offset angle (obtained from site drawings).
- Level the Optical Head and Zero the Vertical Pointer.
- Set the prescribed elevation angle at each head.
- Install the Master Control Unit (may be done at any point in the sequence).
- Make electrical connections.

ACCESS

- The cover to the MCU is secured by quarter-turn latches with padlock provisions on the two front corners of the enclosure.
- Each light emplacement has an Optical Head and Junction Box.
- Junction boxes have a removeable cover secured by captive screws at each corner.
- ***Optical Heads do not have to be accessed for installation.***

INSTALLATION (cont.)

THE MASTER CONTROL UNIT (See Figure 2)

Accessories needed but not shipped with the equipment due to variable site requirements.

- 2-inch NPS to EMT compression fitting (or frangible coupling).
- 2-inch EMT; length as required to set the MCU at its designated or preferred height above local terrain.
- See "Equipment Specifications" for MCU dimensions and weight.

The Master Control Unit (MCU) is provided with a factory-installed compression fitting for 2-inch EMT at the bottom surface of the enclosure. A length of 2-inch EMT and a compatible compression fitting threaded at one end are needed, but typically provided by others unless designated as accessory items at the time of purchase.

IMPORTANT NOTICE

When the MCU is mounted on an in-ground can, the EMT support is generally open to the can for wire passage. The MCU is shipped with a foam plug slotted to allow wire passage. A plug is essential to prevent free passage of air between the in-ground can and the MCU enclosure.

Failure to install this plug or to provide other means of preventing free air passage will allow condensation to collect within the enclosure during certain atmospheric conditions and will void the equipment warranty.

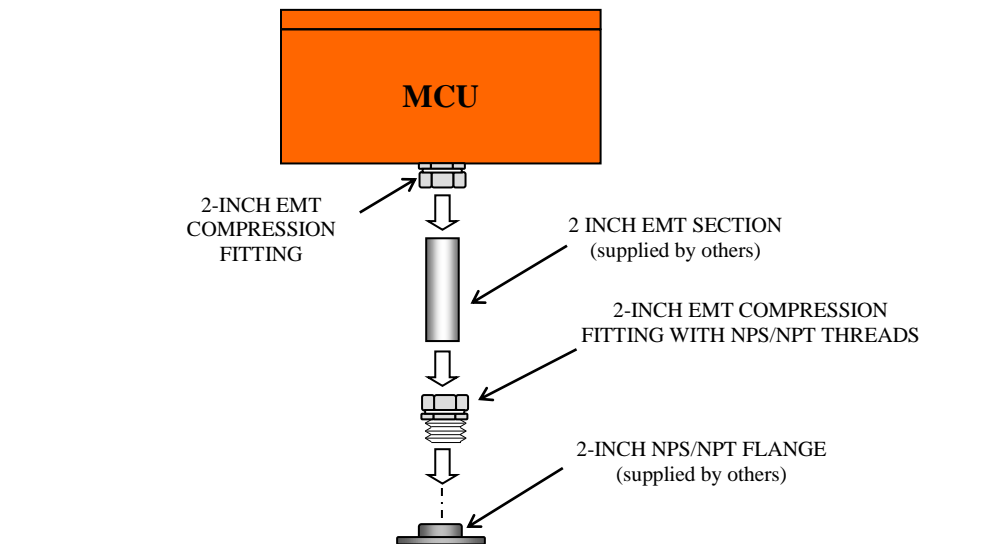

Figure 2
MCU Mounting Details

INSTALLATION (cont.)

The Optical Heads

Junction boxes and Optical Heads are shipped unattached and must be joined together during installation, but the Junction Boxes should be installed before the Optical Heads are attached.

Parts needed for this procedure (at each emplacement):

- Optical Head
- Junction Box
- 2-inch, EMT
 - > Length determined by site requirements
 - > Not furnished with equipment
- Frangible coupling (with compression fitting)

Installation overview

The Optical Heads are mounted onto Junction Boxes and located on each side of the runway near the runway threshold. Location details are typically obtained from drawings provided by others.

Each Junction Box is supported by a single 2-inch-diameter section of EMT and various couplings as shown in Figure 3. The length of the EMT will generally be different from site to site; therefore it is not furnished with the equipment. The length is usually chosen to achieve a certain overall height above grade as called out on site drawings provided by others.

The MCU and one of the light units may be co-located at an emplacement with two threaded receivers separated by 8 inches (203 mm) center-to-center.

Mounting and Assembly Details (Refer to Figure 3)

Use the following procedure as a guide:

- Install the frangible coupling onto the ground attachment device (typically an in-ground can cover or a threaded floor flange bolted to a concrete pad).
- Install the EMT and securely tighten the compression fitting.
- Set the Junction Box onto the upper end of the EMT and lightly tighten the two hex-head bolts. Firm tightening will be done later during the aiming procedure.

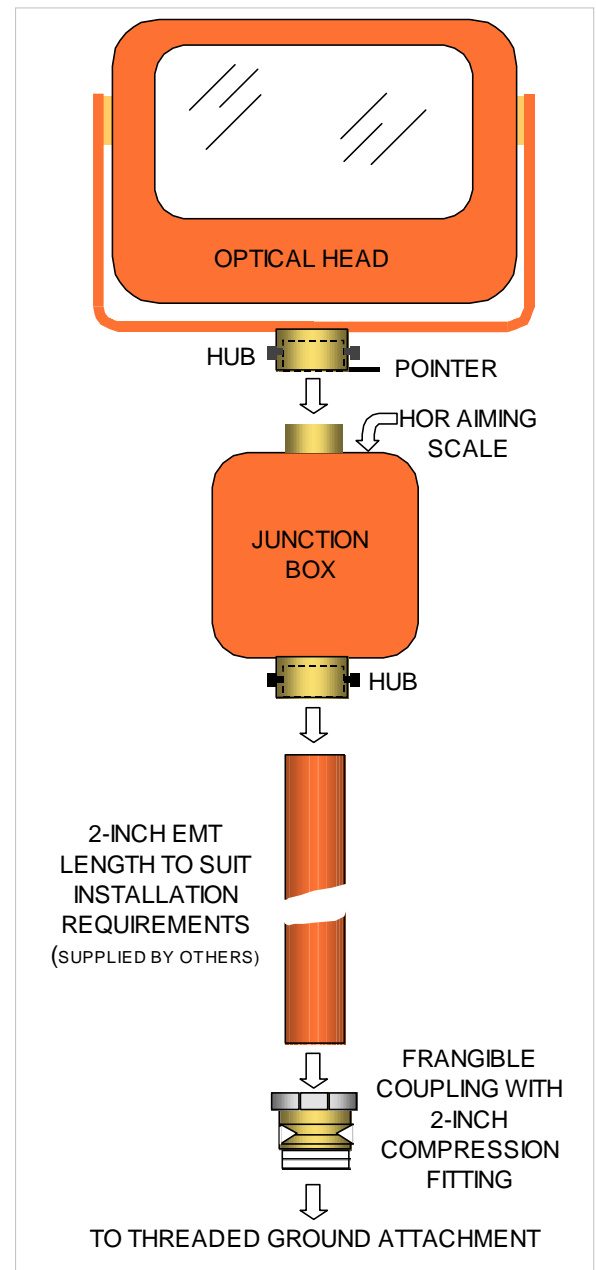

Fig 3
Typical Head Mounting Details

Do not turn the setscrew. It has been properly set at the factory.

INSTALLATION (cont.)

Zeroing and Aiming Instructions

Horizontal

Optically enhanced LEDs, unlike conventional light sources, have very sharply defined beams; aiming is therefore very critical. A horizontal scale has been provided to assist in aiming, but it must be properly aligned with the runway in order to use it effectively. Horizontal scale alignment (zeroing) can be performed before setting the Optical Head onto the Junction Box.

The horizontal scale is attached to the top surface of the Junction Box. The scale ranges from -15° to $+15^{\circ}$ in increments of 1° . A pointer affixed to the Optical Head assembly indicates the aiming direction of the head, but first, the scale must be accurately referenced to the runway. This requires orienting the Junction Box to face exactly downrange; that is, parallel to the centerline of the runway. This can be achieved by following the steps below:

- Establish an aiming target such as a stake or a person placed the same offset distance from the runway centerline as the light emplacement. The target should be at least 200 feet down range from the emplacement.
- Use an edge of the Junction Box as a sighting line and rotate the Junction Box about its supporting pipe until the edge points directly towards the target.
- Securely tighten the hex-head bolts when the Junction Box is aligned with the aiming target. The cone-point setscrew prevents the Junction Box from turning while the bolts are being tightened. The horizontal scale is now referenced to the runway.
- Install the Optical Head onto the Junction Box by setting the head's hub over the mounting plug on the top surface of the J-B.
- Lightly tighten the hub's two hex-head bolts.

Do not turn the setscrew. It has been properly set at the factory.

- Rotate the head until the pointer rests on the horizontal offset angle defined for this emplacement and now firmly tighten the two hex-head bolts.

Vertical

The head is secured vertically by a zero-backlash turnbuckle. Turning the body of the turnbuckle tilts the head. In normal operation the head will be pointing somewhat upwards; that is, above the horizon.

You should avoid tilting the head to point below the horizon because the turnbuckle end-fittings can become disengaged which would allow the head to swing freely on its pivots.

You will use the spirit level residing in a cavity just above the vertical pointer to zero the vertical scale.

To zero the vertical pointer:

- Rotate the body of the turnbuckle until the level bubble lies symmetrically between the two reference lines.
- Loosen the setscrew that holds the vertical pointer and set the pointer to 0° on the scale.
- Tighten the setscrew while the pointer rests on zero.

Use the turnbuckle to set in the vertical aiming angle prescribed for this emplacement.

THIS COMPLETES MOUNTING, ZEROING, AND AIMING

INSTALLATION (cont.)

Wiring

Wiring during installation consists of bringing primary power to the Master Control Unit (MCU), and power and communications (Comm) from the MCU to the two Junction Boxes supporting Optical Heads. All connections are made at terminal blocks that accept bare-wire insertions under screw clamps. No special wire-termination tools are required.

Power wiring consists of three conductors. Two are required for 120 or 240 Vac; the third is for equipment ground.

Comm wiring must satisfy the requirements for an EIA RS-485 data bus. It must have three conductors: Two are for balanced-line data transmission (designated as Comm A and Comm B). The third is an *isolated* ground conductor. The isolated ground is designated as **CGi** at the terminal blocks.

Do not connect CGi to chassis ground.

See External Wiring in the Addendum section of this manual for more wiring information.

Connections in the MCU

Input Wiring

TB101 is the *input* terminal block for Primary Power and Remote Control. See Figure 5.

The MCU power supply self adapts to any voltage from 100 to 260 Vac, 50 or 60 Hz.

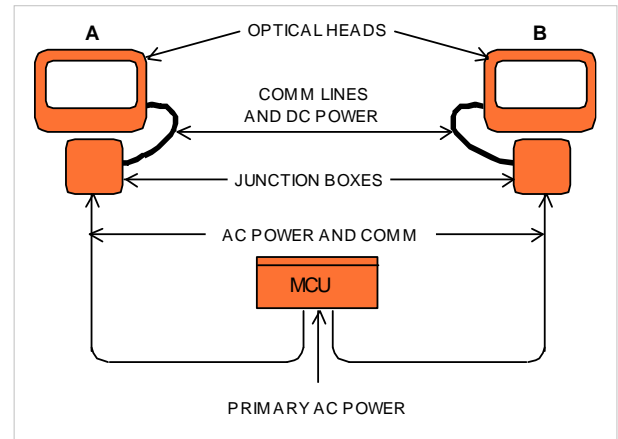

Figure 4
Electrical Overview

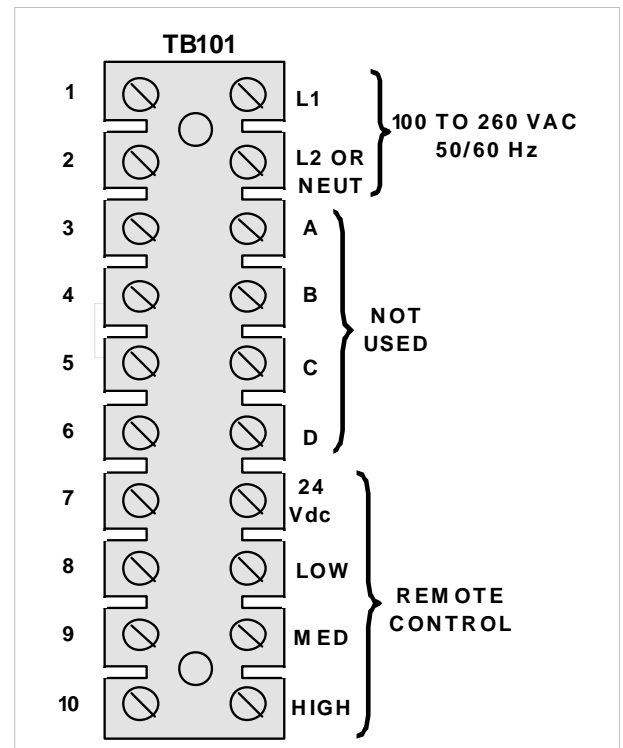
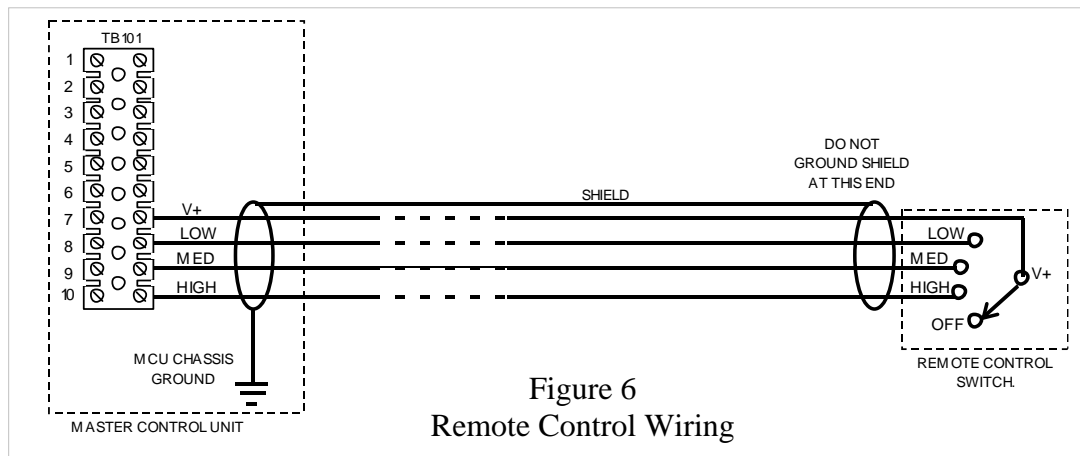

Figure 5
MCU Input Terminal Block

INSTALLATION (cont.)

Remote Control:

Remote Control is compatible with L-854 Radio Receiver/Decoder or any switch that satisfies the function shown in Figure 6. It consists of a four-wire circuit in which one of the conductors provides the switching voltage (24 Vdc). The other three are activated through a switch for Low, Medium, or High intensity. For satisfactory operation up to 1000 feet the lines from the MCU to the Remote Switch should be shielded, and the shield should be grounded at the MCU chassis. The other end of the shield should not be grounded.



MCU Output Wiring

TB102 is the *output* terminal block. It provides connections for power and communications to the Optical Heads through the Junction Boxes. The output wiring connections are identified in Figure 6.

Separate cables are highly recommended for Power and Communications rather than using one multi-conductor cable for both. Since there are two heads there would be two Power Cables and two Comm Cables leading from the MCU to the head emplacements. Terminal Blocks are labeled for all connections at the MCU and at each Junction Box.

Power cables would contain three conductors. Recommended colors are Black for L1, Red for L2 or Neutral, and Green for Chassis Ground. AWG 14 would be satisfactory for a run length of 1000 feet. Power wiring from the MCU to the Junction Boxes is identical for all voltages. There are only two power conductors and a chassis ground conductor. One power conductor is identified as L1 at the terminal blocks. The other power conductor is identified as "L2 or N" (Neutral).

It is not necessary to distinguish between Neutral and L2 at the MCU or the Junction Boxes.

An RS-485 compatible cable with AWG 22 (min) wire such as Belden 3106A or 3107A is recommended for data communications. The data transmission signal is phase-sensitive; therefore a line originating as Comm "A" at the MCU must be connected to Comm "A" at its designated Junction Box. A low capacitance, shielded cable with two twisted pairs may be used in lieu of the Belden cable mentioned above. In this instance the two conductors of the second twisted pair would be used as one conductor for the CGi connection.

Do not connect CGi to chassis ground.

INSTALLATION (cont.)

Wiring At The Junction Boxes

Optical Heads are identified as #1 and #2 at the MCU. Observe the labeling to ensure proper head address for automatic data logging.

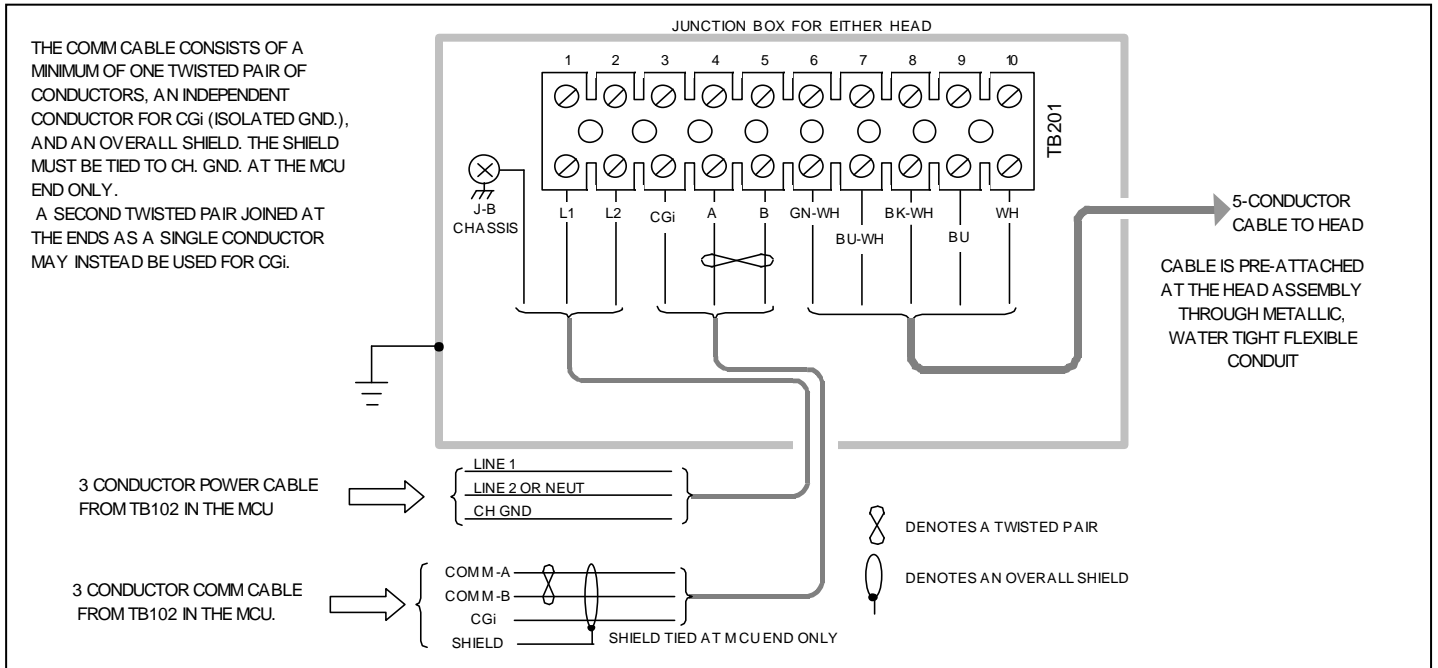

Figure 7
Junction Box wiring

Lightning Protection

A local ground is required at each emplacement for protection against lightning damage.

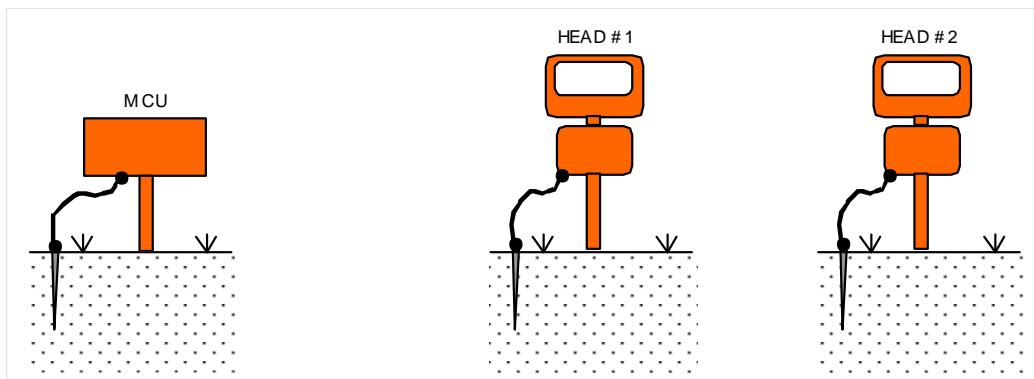

Figure 8
Lightning Protection

GROUNDING THIS EQUIPMENT TO A COUNTERPOISE COULD INCREASE THE RISK OF LIGHTNING DAMAGE

THIS COMPLETES INSTALLATION INSTRUCTIONS

FUNCTIONAL DESCRIPTION

The SAL 1030-V REIL is a Style A/E, current-powered system consisting of two Optical Heads and a Master Control Unit (MCU). Each head has an associated Junction Box that contains a dc Power Supply.

The heads receive flashing and other operating commands from the MCU, and send monitored status information in return. Selected operating parameters are shown visually on a numerical array accommodating values up to xxxx. See Figure 10.

Operation is typically automatic, but flash intensity functions can be set in manually for checkout purposes. The two Optical Heads flash simultaneously upon a single command from the MCU. Programming set in at the factory controls flash rate. There are no selective programming requirements that must be set in at the field.

The light beam is slightly greater than 10° vertically by 30° horizontally. This beam coverage is formed by the composite effect of an array of high-performance, white LEDs.

The array is monitored in such a way that a failure of a complete row or column, or a combination that exceeds a certain number of LEDs at random locations, will turn on an alarm signal light and cause an alarm relay to operate. The alarm relay is for external remote distribution.

Certain Error Codes are generated as a result of monitoring. These are displayed intermittently on the four-segment numerical display.

THEORY OF OPERATION

The SAL 1030-V REIL is a micro-controller based system. Each Optical Head consists of an array of 60, optically enhanced, high performance, LEDs arranged geometrically to form a vertical beam coverage of at least 10° and a horizontal coverage of at least 30°.

The MCU has a single micro-controller card (LSM card) for all input and output functions. An RS-485 data bus provides communications between the MCU and the Optical Heads. A micro-controller card in each head communicates with the LED arrays in that head, collecting status information to send back to the LSM card. Each head is identified by an address code for data tagging at the MCU.

A low-capacitance data transmission line, suitable for RS-485 drivers and receivers, can support satisfactory communications at the baud rate of this system for up to 4000 feet.

While the heads communicate only with the MCU, the MCU has connections outside of the system such as primary power, remote switching, and optionally, a remote alarm activating circuit. These external lines may be subjected to voltage surges or other electrical disturbances. The externally connected lines are provided with over-voltage protection within the MCU. Similar surge protection guards the RS-485 data bus to the Optical Heads.

The MCU is powered by a 24 Vdc switchmode power supply that self adapts to an input voltage ranging from 100 to 260 volts, 50 or 60 Hz..

Each Optical Head is powered by a 48Vdc switchmode power supply located in a Junction Box (part of each head emplacement). These power supplies also self-adapt from 100 to 260 Vac, 50 or 60 Hz.

The Head Controller cyclically scans the LED array collecting temperature, voltage, and flash information. An alarm signal is generated if either head develops an operating condition that falls below a prescribed safe level (EB67D). Examples are: more than 11 (<20%) failed LEDs in a single head, or an incomplete column or row of LEDs. A fail-safe Alarm Relay (contacts close on fail) that can be used for remote alarm signaling is also activated.

OPERATING INSTRUCTIONS

Controls

SW 101 is a cover-activated interlock switch that controls primary power. The plunger of SW 101 may be pulled up to energize the MCU for service.

There are two switches in the MCU for operating control:

The MODE CONTROL rotary switch (SW 102) selects operating modes, manual or automatic (remote).

The INDEX pushbutton switch (SW 103) selects parameters for the four-digit numerical display.

The operating modes from SW 102 are:

- REM (Remote)
- Off
- MAINT (Maintenance)
- LOW
- MED (Medium)
- HIGH

Use REM to control flash intensity from CCR current level (via the Current-Sensing Module).

Use OFF to inhibit flashing while the system is energized.

Use MAINT to operate the heads in a low-level, steady (non-flashing) mode (May help to identify the location of a non-operating LED).

Use LOW to flash the LEDs at Low intensity.

Use MED to flash the LEDs at Medium intensity.

Use HIGH to flash the LEDs at High intensity.

Depressing the INDEX switch cycles the status LEDs and the data displayed on the numerical LED array.

VOLTS: When lit the numeric array displays the average voltage across each group of 12 LEDs in both heads combined.

TEMP: When lit the numeric array displays the average operating temperature of the LEDs in both Optical Heads combined.

HOURS: When lit the numeric array displays the total no-fault operating hours at HIGH intensity.

To activate the system when the cover to the MCU is open and primary power is applied:

- Pull the Interlock Switch up (Service mode).
- Turn the Rotary Switch to any of the positions below:
 - > MAINT
 - > LOW
 - > MED
 - >HIGH

To activate the system for Normal Operation:

- Place the Rotary Switch in the REM position.
- Close the cover
- Apply primary power

STATUS MONITORING

There are two LEDs for critical status monitoring.

CAUTION: This LED lights when an abnormal, but not disabling, condition exists. It signals attention and further investigation into the condition and its cause. Examples are:

- More than 2 LEDs have failed (composite of both heads).
- Temperature has been reported to be more than **80 °C**.
- A voltage has been reported as below **28 Vdc**.

See the troubleshooting section for recommended actions if any of these conditions arise.

ALARM: This LED lights and an ALARM relay operates (de-energizes) when a disabling condition has developed. Examples are:

- More than **12** LEDs fail to report or to flash in either head.
- One head is not reporting.

See the troubleshooting section for recommended actions if any of these conditions arise.

TROUBLESHOOTING

Problems addressed in this section fall into two broad categories: Those encountered upon initial turn-on following installation, and evolving problems that occur after the system has been operating properly for any length of time. The most common problem that will likely be encountered is failure to flash. There are many possible causes for flash failure, especially upon initial turn-on. A flash failure generally involves both optical heads. The reason is not that both heads are necessarily at fault, but because the Master Controller has shut them both down due to an abnormal condition that might affect the view presented to an approaching pilot. In fact, the system is not allowed to flash unless both heads meet the minimum required standard of operation based on the number of non-operating LEDs. Another problem that can cause total flash shutdown is loss of communication to either head. Neither head is allowed to flash independently.

A. Problems occurring at installation

The most common problems occurring when a system is first turned on are failure to flash at all, and Remote Control problems.

1. Failure to Flash.

A number of conditions could cause initial failure to flash.

- Upon applying power observe whether the numeric display and status LEDs on the Master Control Board light up. If not, check the source of primary power, and the fuses F1 & F2.
- Make sure the Mode Selector Switch in the MCU is set to Low, Med, or High.
- Check both Comm lines to verify that Comm-A in the MCU (TB102) goes to Comm-A in the respective remote Junction Box (TB201), and that Comm-B similarly goes to Comm-B.
- Observe whether the heads flash briefly (two or three flashes) directly upon applying power. If only one head flashes briefly then quit look for a communication problem to the other head (remember that both heads must operate in order to sustain flashing).

2. Remote Control Problem

The system fails to respond to remote control commands or responds incorrectly.

- Be sure the Mode Selector Switch is set to the REM position.
- Be sure that the Remote Circuit is wired as shown in Figure 5B.
- If the switch is set to REM and yet fails to respond correctly proceed as follows:
 - > At TB101 in the MCU disconnect all four Remote Control lines from the external Remote Control Switch.
 - > Verify with a voltmeter that +24 Vdc is present at TB1-5.
 - > Temporarily connect TB101-5 and TB1-6 together and verify that the LOW mode LED on the Master Control board lights up.
 - > The MED LED should light up when TB101-5 & 7 are connected.
 - > The HIGH LED should light up when TB101-5 & 8 are connected.

If these conditions occur as described the problem must be in the external Remote Control circuit. See "Troubleshooting the external Remote Control circuit".

If these conditions fail as described the Master Control board is faulty. Replace the circuit board.

TROUBLESHOOTING (cont)

- Reconnect the external V+ wire to TB101-5 and again measure the voltage at that terminal. If it measures +24 Vdc, the external V+ line is OK. If it measures zero the line must be shorted.
- If TB101-5 checks out OK, proceed to re-connect LOW, MED, & HIGH while checking the voltage at TB101-5 after each one is connected. Any connection that affects the 24Vdc level must be investigated and corrected.
- If a Remote Control problem persists after all of the external circuit wires are connected and verified the problem is likely due to interference on the wires between the MCU and the remote switch. These wires should be shielded and the shield tied to the MCU chassis. The shield should NOT be tied at the remote switch end.

B. Evolving Problems

The manifestation of an evolving problem is nearly always a failure of both heads to flash. That is because the software instructions are that unsatisfactory operation within either head shall disable flashing of both heads to prevent a confusing presentation to a pilot. Therefore steps must be taken to identify the source of the problem, which most likely will be confined to only one head.

When flashing has been shut down due to a serious malfunction the system will override the shutdown briefly upon cycling primary power. This enables one to evaluate the cause by directly viewing each of the heads, as power is re-applied.

- Choose the MAINT MODE position on the Mode Selector Switch. In this mode the heads are operated in a steady, low level of illumination suitable for direct viewing. One can quickly ascertain which head is creating the malfunction by not responding at all, or exhibiting a malfunctioning sector.
- If none of the LEDs in one of the heads are operating check the power supply in that head's Junction Box. Look for 48 Vdc between the Blue and White wires (plus & minus 48 Volts) at TB201. If there is no dc voltage at those terminals verify that primary power is present at terminals L1 & L2. With primary power present but no dc voltage the power supply is defective and must be replaced.
- If the dc voltage checks OK then the problem could be in the Comm cable or connections.
- If dc voltage is present and the LEDs are on (steady mode), but a portion of the array is unlit the problem resides within the head. Contact Customer Service at SAL Technology if this condition has been ascertained.

MAINTENANCE

The following tips will help assure long, reliable operation.

- Keep door and cover seals in good condition. Repair or replace any that are damaged.
- Inspect and maintain grounding at each emplacement.
- Keep earth grounds separate from any counterpoise conductor.
- Be sure there is no free air exchange between an in-ground chamber and the MCU.
- Be sure there is no free air exchange between an in-ground chamber and a Junction Box.
- Periodically check the tightness of terminal block clamping screws.
- Inspect the flexible conduit between the Optical Heads and associated Junction Boxes
- Repair or replace any damaged conduit or fitting.

REPLACEABLE PARTS

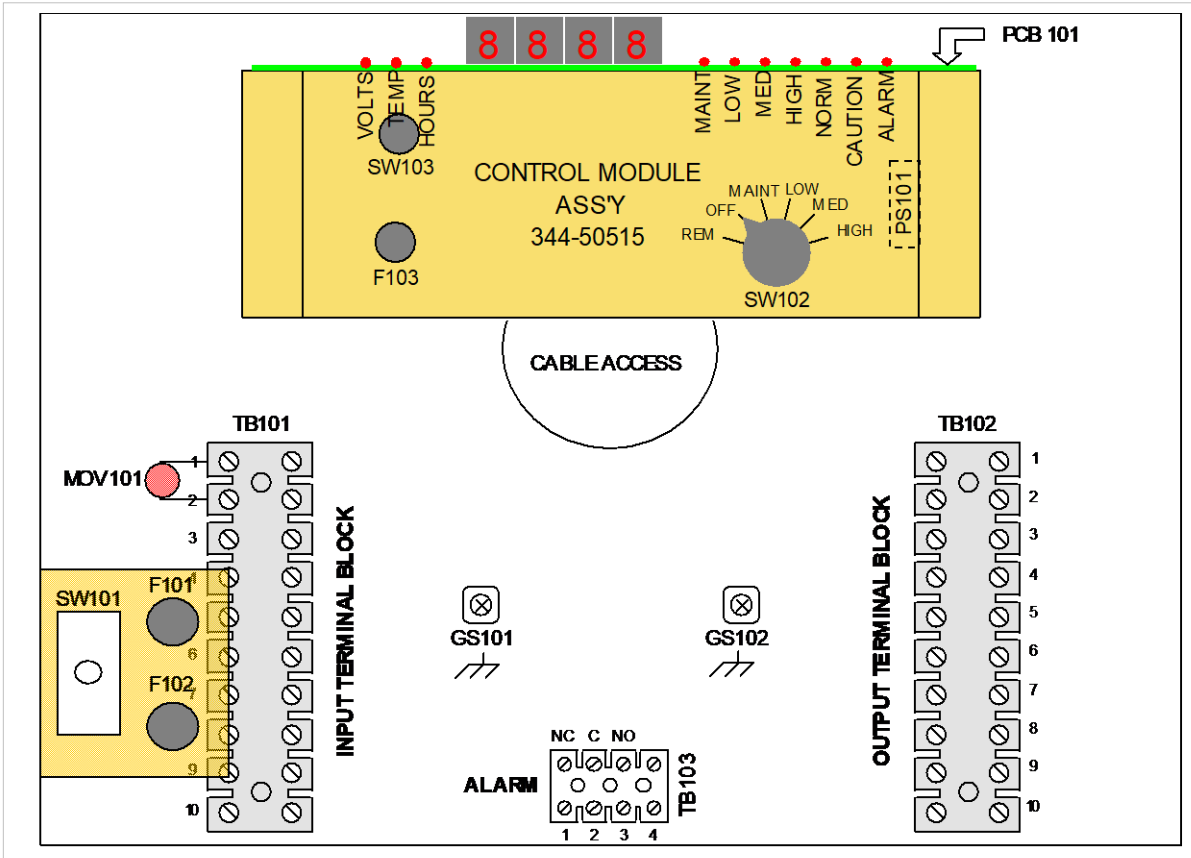

Figure 9
Component Identification

Table 4, Replaceable Parts

REF	DESCRIPTION	PN
F 101, F102, 103	Fuse, 1.5 A	55-00267
MOV101	250 Vac Varistor	55-00203
PS 101	24 Vdc Power supply	44-00104
PS 201	48 Vdc Power Supply (Junction Box location)	44-00146
MOV-101, 102	Surge Suppressor, 130 Vac	55-00202
PCB-101	Printed Circuit Board, LSM	344-30105
SW101, 102	Interlock Switch	44-00107
FH 1030	Flash Head Assembly	344-40520

ADDENDUM A

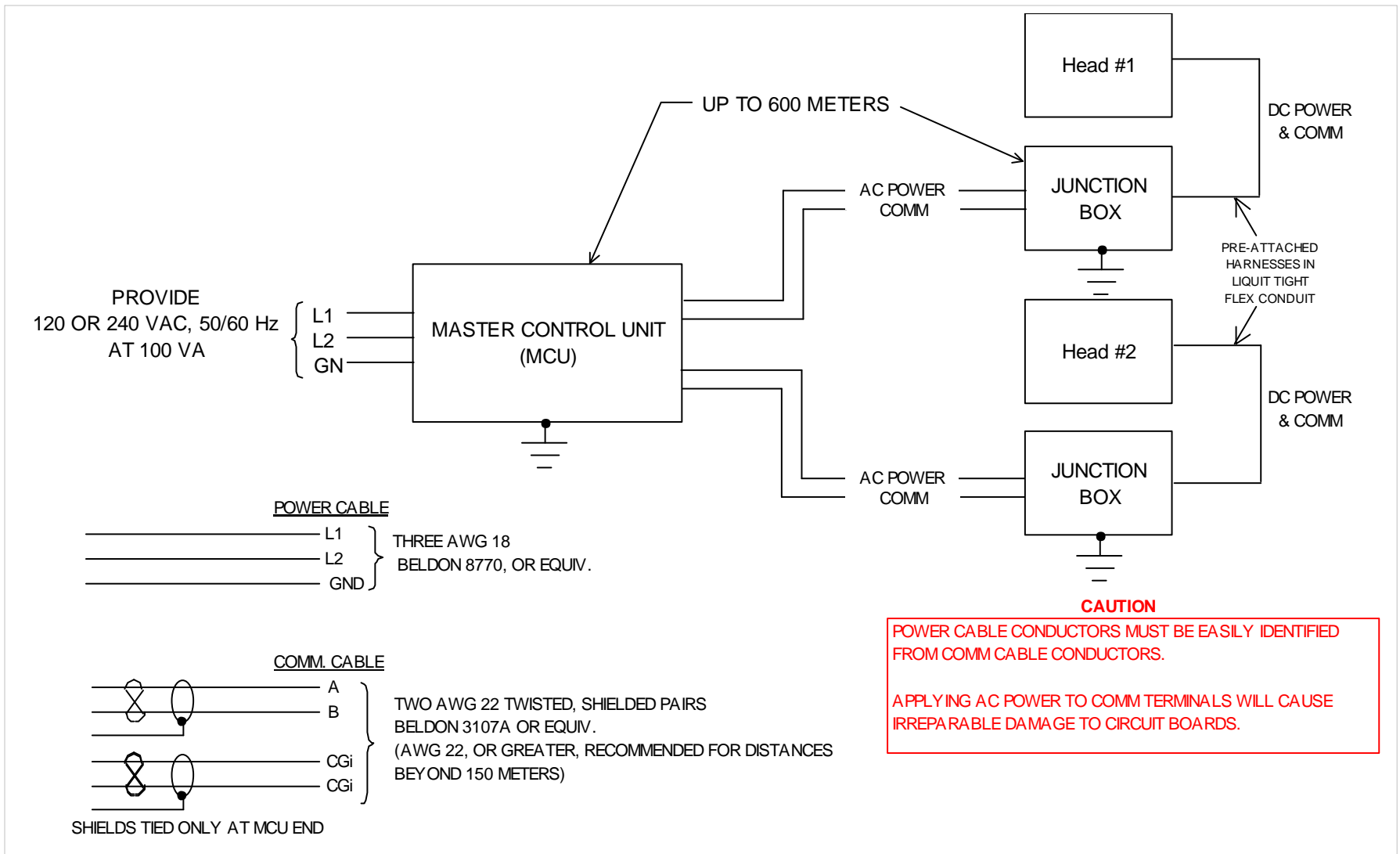

Figure A-1
External Wiring Requirements For SAL-1030V

ADDENDUM A

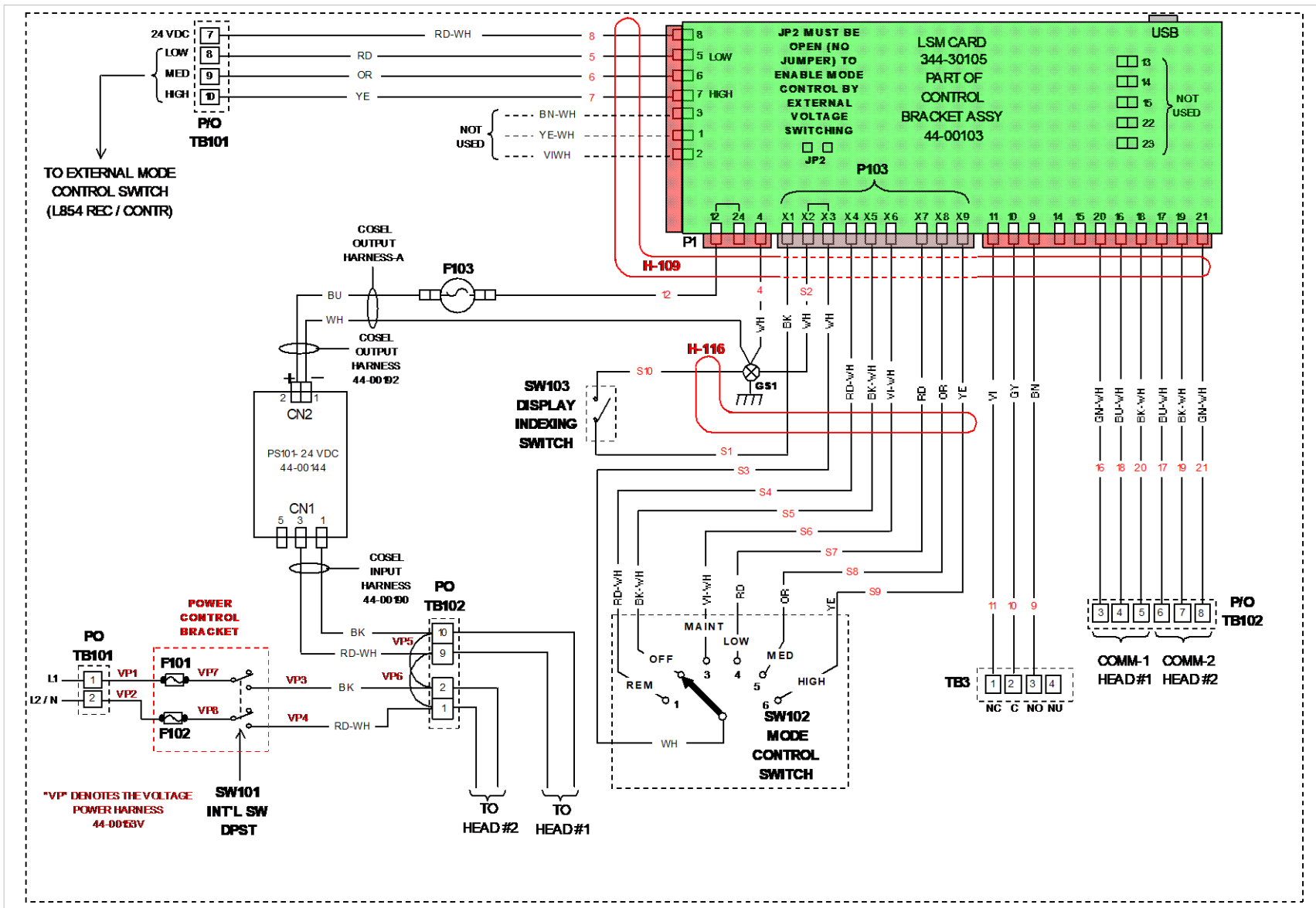

Figure A-2
MCU Wiring Diagram