

LED Runway Guard Light
L-804 Mode 1 and Mode 2 User
Manual
Revision 1.3

In accordance with:
FAA
Advisory Circular AC-150/5345-46
And
Engineering Brief 67

Manufactured by:
Airport Lighting Company 108 Fairgrounds Drive
Manlius, New York 13104
(315) 682-6460
Email: info@airportlightingcompany.com
Website: www.airportlightingcompany.com



Warranty – LED Light Source Products FAA EB67D

Products manufactured by Airport Lighting Company (ALC) which use LEDs as a light source are warranted against mechanical and physical defects in design or manufacture for a period of 2 years from date of installation per the applicable FAA Advisory Circular and against electrical defects in design or manufacture of the LED or LED specific circuitry for a period of 4 years per FAA EB67D. ALC will correct such defects by repair or replacement, at its option, provided the products have been properly handled and stored prior to installation, properly installed and operated after installation, and provided further that the Buyer has notified ALC in writing within the warranty period and within a reasonable time after notice of such defects. Refer to handling, storage, installation and operational instructions for proper procedural guidance that must be followed to maintain warranty provisions.

This warranty is in effect for the specified term as long as the equipment, in ALC's judgment, has not been altered in such a way as to affect the equipment adversely, subject to accident, negligence, improper storage, and has been operated and maintained in accordance with accepted FAA guidelines as described in AC 150/5340-26 and ALC's published operational guidelines.

ALC reserves the right to examine products about which a claim has been made. Equipment must be presented in the same condition as when the defect was discovered. ALC also reserves the right to require the return of equipment to establish any claim.

Disclaimer: ALC's obligation under this warranty is limited to repair or replacement of defective equipment sold by ALC at no cost to Buyer. This does not include any other costs such as the cost of removal, shipping, or installation of the defective part or repaired or replaced product, including labor or any consequential damages of any kind. Warranty services provided under this agreement do not assure uninterrupted operations of LED illuminated equipment. ALC shall not be liable for any indirect or consequential damages.

ALC's liability under no circumstances will exceed its sales price of the products claimed to be defective. All transportation costs under this warranty are the responsibility of the purchaser. Replacement parts and/or equipment provided under this warranty are covered under the same terms until the expiration of the original warranty period that began upon the first installation of the equipment.

This is ALC's sole and exclusive warranty with respect to the equipment sold to the Buyer. There are no express or implied warranties of fitness for any particular purpose or any implied warranties other than those made expressly herein.

ALC shall not be liable to the purchaser of this product or third parties for indirect or consequential damages, or for damages arising from the use of any options or parts other than those designated by ALC as approved products. Damage caused by lightning, flood and other natural or manmade causes are outside the scope of this warranty.

Table of Contents

1.1 General Information	3
1.2 Mode 1 (Series - Powered)	4
1.3 Mode 2 (Parallel - Powered).....	4
1.4 Additional Features	5
1.5 Power Consumption Mode 1 (Series - Powered)	5
1.6 Power Consumption Mode 2 (Parallel - Powered).....	5
2.1 FAA References and Siting Requirements	5
3.1 Installation	8
3.2 System Test, Mode 1 (Series Powered)	11
3.3 System Test, Mode 2 (Parallel Powered)	11
3.4 Maintenance.....	12
3.5 Replacing a Broken Frangible Column.....	12
4.1 Runway Guard Light Operational Outline	13
4.2 Mode 1 (Series-Powered) RGL Power Supply.....	13
4.3 Mode 2 (Parallel-Powered) RGL Power Supply	13
4.4 RGL Control Board	13
4.5 Fault Detection, Light Engine Failure.....	14
4.6 Fault Detection, Flash Failure	14
4.7 Guard Light Controller Trouble Shooting	15

List of Figures

Figure 1: FAA Guard Light Field Placement (from AC 150/5340-30)	7
Figure 2: Installing Frangible Column	8
Figure 3: Anti-rotation clamp, nut and baseplate	8
Figure 4: Plug Retainer.....	9
Figure 5: Initial Placement.....	9
Figure 6: Tether.....	10
Figure 7: Vertical Adjustment.....	11
Figure 8: L-804 Runway Guard Light Control Board.....	15
Figure 9: Wiring diagram for a current style L-804 Runway Guard Light shown without monitoring.....	16
Figure 10: Wiring diagram for a current style L-804 Runway Guard Light shown with monitoring.....	16
Figure 11: Wiring diagram for a voltage style L-804 Runway Guard Light shown without monitoring.....	16
Figure 12: Wiring diagram for a voltage style L-804 Runway Guard Light shown with monitoring	16

List of Tables

Table 1: Recommended Spare Parts	16
Table 2: Trouble Shooting	17

1.1 General Information

The Airport Lighting Company LED Runway Guard Light (LED RGL) is a FAA certified L-804. The L-804 LED RGL from Airport Lighting Company comes in four configurations; Mode 1 (Series-Powered), Mode 2 (Parallel-Powered), in either a monitored or unmonitored configuration. The L-804 LED RGL comes preassembled from the factory. The Airport Lighting Company LED RGL comes with a 12" L-867 base plate with an anti-rotation tab and clamp designed to prevent the unit from rotating when exposed to jet blasts. This all aluminum design from the frangible column to the LED enclosure prevents corrosion. All internal electrical connections are completed at the factory. All that is required from the contractor is to connect the fixture into the correct electrical supply, bolt the unit to the light base, and make the correct vertical and horizontal angle adjustments.

1.2 Mode 1 (Series - Powered)

The L804 Mode 1 unit runs from constant current airfield electrical system using a 65W, 6.6A isolation transformer. The L-804 Mode 1 monitored units use a 5 pin plug that includes a ground pin. The monitored units are configured to have a normally-closed circuit connection when operating properly. Alternatively the unit can be configured as a normally-open circuit (troubleshooting 1.1). Unmonitored units use a 2 pin plug. Also supplied with an unmonitored system are a #6 wire crimp and a toothed washer. The contractor is expected to supply external ground wire and ground connection on unmonitored systems.

1.3 Mode 2 (Parallel - Powered)

The L-804 Mode 2 unit operates on 100-240 VAC at 50-60Hertz. The L-804 Mode 2 uses a photodiode to discriminate night from day, and switches the light intensity accordingly. Monitored units use a 5 pin plug that includes a ground pin. The monitored units are configured to have a normally-closed circuit connection when operating properly. Alternatively, the unit can be configured as a normallyopen circuit (troubleshooting 1.1). Unmonitored units use a 2 pin plug. Also supplied with the unmonitored system are a #6 wire crimp and a toothed washer.

The contractor is expected to supply external ground wire and ground connection on unmonitored systems.

1.4 Additional Features

This unit is designed to meet FAA light specifications for 50,000 hours of operation. Internal temperature monitoring automatically adjusts the LED intensity to maintain a steady light output across the operating temperature range. The unit records faults in internal memory so that Airport Lighting Company can review the performance of any unit that is returned to them.

1.5 Power Consumption Mode 1 (Series - Powered)

<u>Supply Current</u>	<u>Power Factor</u>	<u>VA</u>
6.6	0.96	59
5.2	0.95	40
4.1	0.95	23
3.4	0.94	18
2.8	0.94	20

(Measured on ferro resonant CCR regulator with a 65W isolation transformer)

<u>Supply Current</u>	<u>VA</u>
6.6	68
5.2	40
4.1	27
3.4	21
2.8	17

(Measured on SCR CCR regulator with a 65W isolation transformer)

1.6 Power Consumption Mode 2 (Parallel - Powered)

<u>Light Output</u>	<u>Watts</u>
Full Intensity	34.7
Low Intensity	15.5

(Measured at 120V, 60 Hz)

2.1 FAA References and Siting Requirements

Note: When referencing FAA advisory circulars and engineering briefs, Airport Lighting Company will quote directly from the advisory circular or engineering brief. All FAA references will be highlighted.

(From AC150/5430-30, sections b and c do not pertain to elevated guard lights)

4.4. RUNWAY GUARD LIGHTS.

a. General. Elevated and in-pavement RGLs serve the same purpose and are generally not both installed at the same runway holding position. However, if snow could obscure in-pavement RGLs, or there is an acute angle between the holding position and the direction of approach to the holding position, it may be advantageous to supplement in-pavement RGLs with elevated RGLs. Each elevated RGL fixture consists of two alternately illuminated, unidirectional yellow lights. In-pavement RGLs consist of a row of alternately illuminated, unidirectional yellow lights. Refer to AC 120-57 for criteria on the application of RGLs.

d. Location of Elevated RGLs. Elevated RGLs are collocated with the runway holding position marking and are normally installed on each side of the taxiway. The distance from the defined taxiway edge to the near side of an installed light fixture must be 10 to 17 feet (3 to 5 m). In order to avoid undesirable spots, the RGL may be moved up to 10 feet (3 m) farther from the runway, but may not be moved toward the runway (see Figure 50). If a stop bar is installed at the runway holding position, the elevated RGL must be located at least 3 feet, 6 inches (1 m) outboard of the elevated stop bar light. The RGL must not interfere with the readability of the runway holding position sign.

e. Light Beam Orientation for Elevated RGLs. RGLs must be oriented to maximize the visibility of the light to pilots of aircraft approaching the runway holding position. The orientation must be specified by the design engineer to aim the center of the light beam toward the aircraft cockpit when the aircraft is between 150 feet (45 m) and 200 feet (60 m) from the holding position, along the predominant taxi path to the holding position. The vertical aiming angle must be set between 5 degrees and 10 degrees above the horizontal. The designer must specify aiming of the lights such that the steady-burning intensity at all viewing positions between 150 feet (45 m) and 200 feet (60 m) from the holding position is at least 300 candela (cd) for an incandescent lamp when operated at the highest intensity step. (Refer to AC 150/5345-46 for specifications for the light intensity and beam spread of the L-804 RGL fixture.) If these criteria cannot be met for all taxi paths to the holding position, consider using multiple fixtures aimed to adequately cover the different taxi paths. Use in-pavement fixtures to increase the viewing coverage, or aim the single fixtures on each side of the holding position to optimize the illumination of the predominant taxi path.

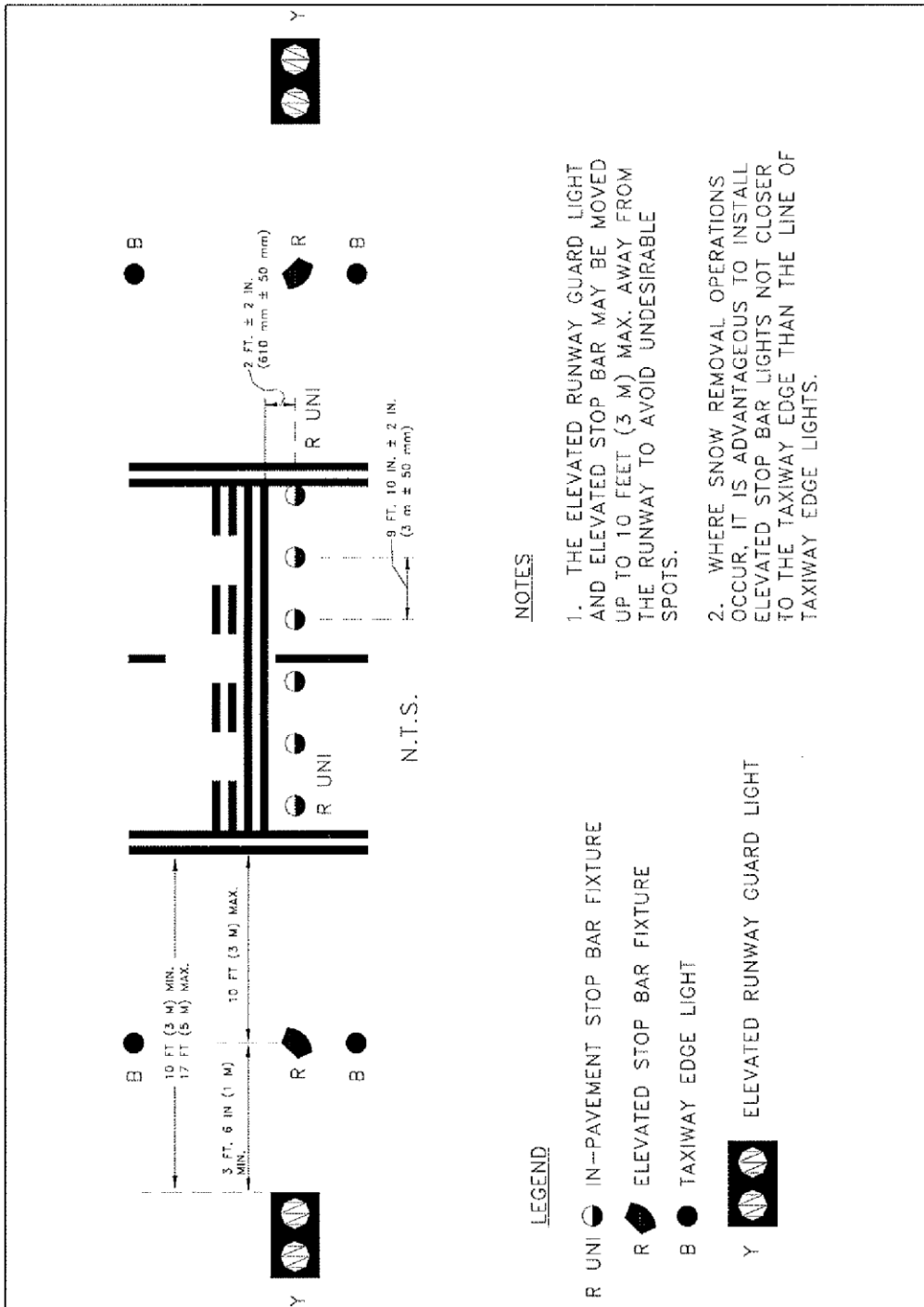

Figure 50. Elevated RGL and Stop Bar Configuration.

Figure 1: FAA Guard Light Field Placement (from AC 150/5340-30)

3.1 Installation

The Airport lighting Company L-804 LED RGL is pre-assembled at the factory. Remove the unit from the cardboard box and lay it on its side. Run the harness thru the frangible column. Install the quick pin into the zero position hole in the column and snug the $\frac{1}{4}$ -20 x $\frac{5}{8}$ " hex screws to hold the column temporarily.



Figure 2: Installing Frangible Column

Slide the anti-rotation clamp onto the frangible column. Thread the jam nut onto the frangible column. Pass the lower harness thru the L-867 base plate and thread the base plate onto the frangible column until it is snug.

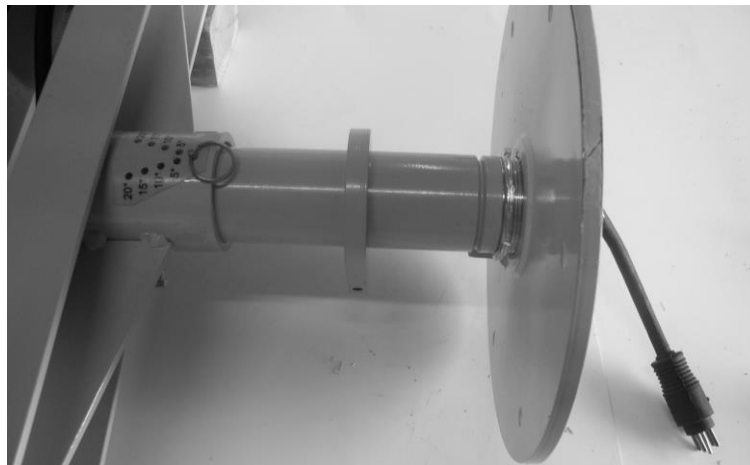

Figure 3: Anti-rotation clamp, jam nut and baseplate

Connect lower harness to the upper harness. Attach the harness retainer to the bottom of the baseplate.

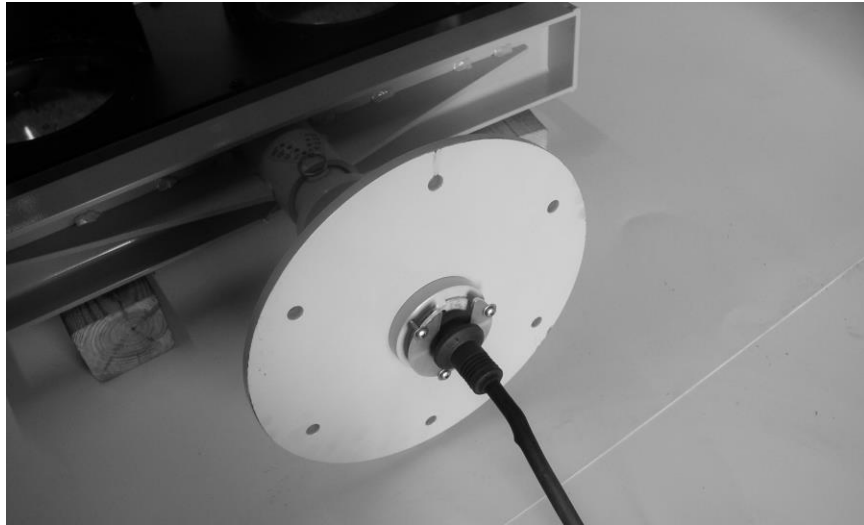

Figure 4: Plug Retainer

Stand the unit up and line up the base plate holes up with the holes in the base can so that the LED RGL is pointed in the correct general direction.

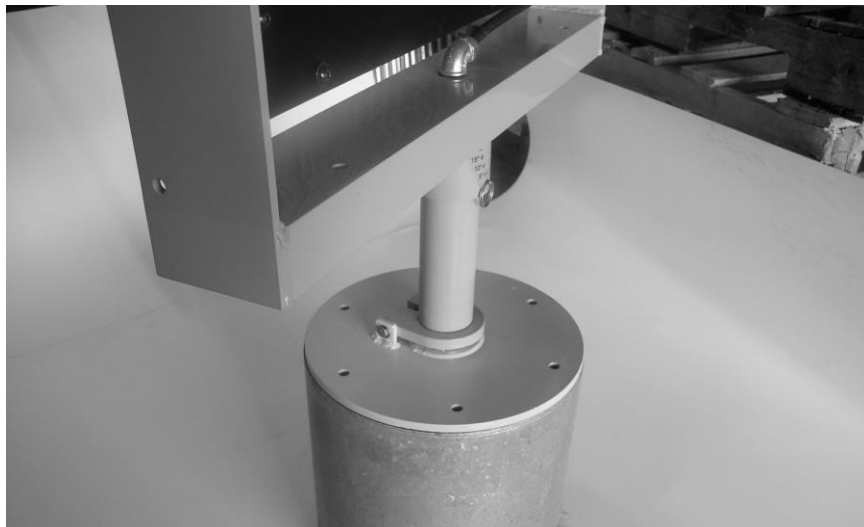

Figure 5: Initial Placement

Connect one end of the tether to the mounting frame. Connect the other end of the tether to the baseplate. Install the 5 remaining hex bolts in the baseplate.

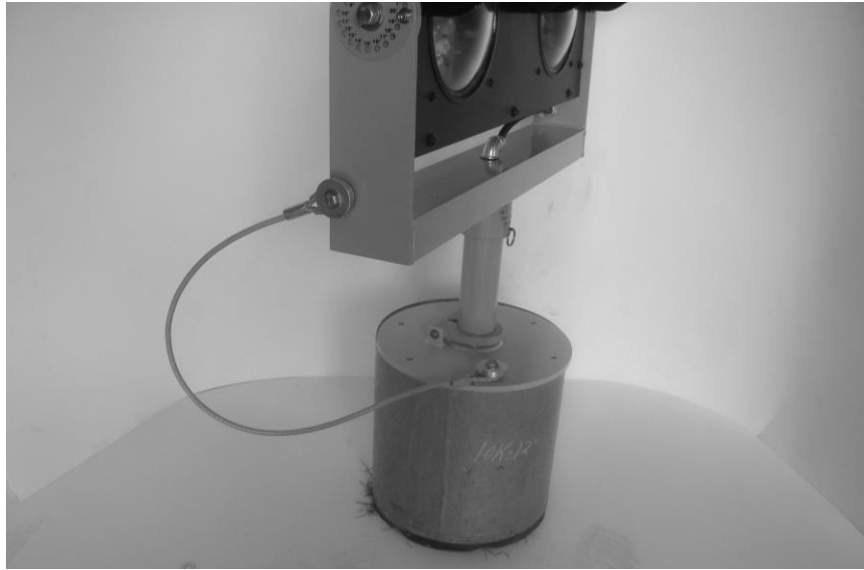

Figure 6: Tether

Tighten the jam nut on the frangible column. Slide the anti-rotation clamp down and pass the bolt through the retaining tab on the guard light base plate. Tighten the bolt and check that the guard light is secure. Loosen the 2 bolts securing the guard light to the frangible column and remove the quick pin. Aim the guard light in the correct direction. Reinstall the quick pin in the correct hole and tighten the 2 bolts that secure the guard light to the frangible column.



Figure 7: Vertical Adjustment

Adjust the vertical position by removing the $\frac{1}{4}$ -20 hex-head cap screws in the vertical adjustment holes on each side. Loosen the $\frac{1}{2}$ " bolt enough to allow the guard light to rotate up and down. Do **NOT** remove the $\frac{1}{2}$ " bolt. Adjust the guard light to the correct vertical angle. Thread the $\frac{1}{4}$ -20 hex-head cap screws into the adjustment holes at the correct location. When all screws have been threaded, tighten down the $\frac{1}{4}$ -20 socket-head cap screws and the $\frac{1}{2}$ " bolt.

3.2 System Test, Mode 1 (Series Powered)

Turn on the guard light. The system has a short initial power-up delay and should be fully operational within 5 seconds. Go through each step on the constant current regulator and observe the changes in light intensity. For monitored systems, check to make sure the guard light is seen as a closed circuit by the monitoring system. If the monitoring system needs to be seen as an open circuit, refer to the trouble shooting section of this manual.

3.3 System Test, Mode 2 (Parallel Powered)

Turn on power to the guard light. The system has a short initial power-up delay and should be fully operational within 5 seconds. If it is day time, note the light intensity of the guard light after 30 seconds of operation. Cover the photodiode and allow the system at least 30 seconds to switch from day to nighttime

operation. Check to make sure the light output has decreased for night time operation when the photodiode is covered. Uncover the photodiode and the light output put should increase within 30 seconds to full intensity when it switches to daytime operation mode. For monitored systems, check to make sure the guard light is seen as a closed circuit by the monitoring system. If the monitoring system needs to be seen as an open circuit, refer to the trouble shooting section of this manual.

3.4 Maintenance

Check the following;

Does the system come on?

Is the system alternate flashing 45-50 times a minute?

Are all LEDs lighting up? If any LED does not light up, note which LED is not working. If a light engine does not light up see the Trouble shooting section.

Does the system change intensity?

Mode 1 (Series Powered)

Does the guard light change intensity with different current steps?

Mode 2 (Parallel Powered)

Does the guard light reduce intensity when the photo diode is covered for a continuous 60 seconds?

Clean surfaces with a damp cloth. Wash the lenses and photodiode with a mild soap and water.

Check all wire harnesses and electrical connections.

3.5 Replacing a Broken Frangible Column

The frangible column will break ½” above the baseplate. Remove the antirotation clamp. A pipe wrench should be able to remove the lower portion of the frangible column. The lower portion of the frangible column also has a hole in the side so that a 2 ½” spanner wrench can be used to remove the remaining column section. (Suggested tool: Armstrong 34-219 spanner wrench)

4.1 Runway Guard Light Operational Outline

The runway guard light can be supplied in either a Mode 1 (series – powered) configuration. Mode 1 operates on a constant current airfield electrical supply that supplies constant current. The Mode 1 will operate on a 5 step CCR that supplies 2.8 thru 6.6 amps, or a 3 step CCR that supplies 4.8 thru 6.6 amps. The Mode 2 (parallel – powered) can be powered by a voltage source that delivers 100 to 240 VAC at 50 – 60 Hertz. Though Mode 1 and Mode 2 guard lights appear very similar they use different power supplies and the correct power supply must be specified.

4.2 Mode 1 (Series-Powered) RGL Power Supply

The Series-Powered RGL is connected to a 65 Watt isolation transformer. The secondary power enters the RGL cabinet and connects to the input of a Constant Current Power Supply. The output of the ALC Constant Current Power Supply is then connected to an RGL Control Board. The output of the Constant Current Power Supply is a regulated 20-21 VDC. The Constant Current Power Supply also measures the loop current and sends a signal to the control board informing the control board of the input current step.

4.3 Mode 2 (Parallel-Powered) RGL Power Supply

The Parallel-Powered RGL can be connected to a voltage source of either 110 or 220 VAC single phase, from 50 to 60 Hertz. The input power is connected to the input of the voltage power supply. The output of the power supply (a regulated 20-21 VDC) is connected to the RGL Control Board.

4.4 RGL Control Board

The Airport Lighting Company RGL Control Board is common to both the Mode 1 and Mode 2 RGL units. When used with a Mode 1 (Series Powered) power supply the control board receives 2 inputs. The first input is 20-21 regulated VDC, the second input is a digital signal that informs the RGL Control Board what current is being seen by the Constant Current Power Supply. When used with a

Mode 2 (Parallel-Powered) power supply the control board receives 2 inputs. The first input is 20-21 VDC from the voltage power supply, the second input comes from a photocell that measures the ambient light level. Once the RGL Control Board knows the ambient light level, it chooses between the daytime full intensity and nighttime low intensity settings.

4.5 Fault Detection, Light Engine Failure

The RGL Control Board monitors the 2 light engines in the RGL. The control board evaluates two failure modes of the light engines: an open circuit in a string of LEDs, and a short circuit across a failed LED. Each light engine consists of 4 strings of 6 LEDs each. Should one string go open, the system will lose 25% of the light output, and will consider this a light engine failure. The second mode of failure for an LED is to fail short. In order to check for LEDs that have failed short, the RGL Control Board measures the voltage across a string of LEDs and checks it against known values. From the measured voltage the RGL Control Board is able to count the number of LEDs that have failed short. If the total number of failed short LEDs reaches 6, in any LED light engine, the system will consider this a light engine failure. If a light engine failure is observed by the control board, the light engine that has failed will be shut down, and the monitoring relay will be deactivated, signaling a failure to the airport, and the remaining light engine will continue to flash normally.

4.6 Fault Detection, Flash Failure

The RGL Control Board controls the alternate flashing of the RGL. There is no separate flashing unit. The monitoring relay of the unit is activated during normal operation. Any monitored failure, deactivates the monitoring relay, signaling a fault condition. There are also indicator LEDs on the control board corresponding to the various faults. When a bad LED light engine is detected the relay is deactivated. A flash failure means that the RGL Control Board itself is not operating, and the relay will be in the deactivated state. Additional protections for the controller include a watchdog timer that will restart the controller should it become locked-up.

4.7 Guard Light Controller Trouble Shooting

There are 8 LEDs on the RGL Control Board

20V OK	Green LED ON	on when working properly
5V OK	Green LED ON	on when working properly
SYSTEM OK	Green LED ON	on when working properly
Left ON	Amber LED FLASHING	with Left Light Engine
Right ON	Amber LED FLASHING	with Right Light Engine
Left Fail	Red LED OFF	only comes on when faulty
Right Fail	Red LED OFF	only comes on when faulty
Controller Failed	Red LED OFF	only comes on when faulty

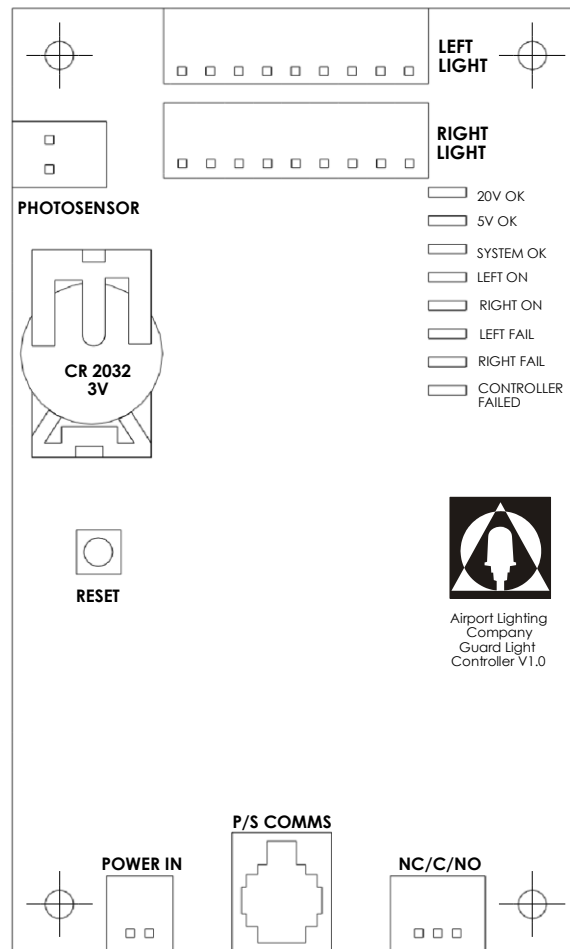

Figure 8: L-804 Runway Guard Light Control Board

If any fault is seen on the RGL Control Board, the first thing to do is to make note of the LEDs that are on. Next look at each light engine and make note of whether or not they are flashing and whether or not all LEDs are working. Then turn the guard light off and restart it after a minute or two. Record any changes in the how it worked after being restarted. If it has been determined that it is a light engine failure, turn the power off and swap the wire harnesses where they plug into the RGL Control Board, left to right and right to left. This will determine whether the problem follows the light engine or the RGL Control Board. If a light engine failure is determined, replace the light engine. If a control board failure has been determined, replace the RGL Control Board. Please contact Airport Lighting Company any time a failure has occurred. An email can be sent to: info@airportlightingcompany.com.

Table 1: Recommended Spare Parts

Part Number	Part	Compatible
RGL-18	LED Light Engine	Mode 1 and Mode 2
RGL-19	Control Board	Mode 1 and Mode 2
RGL-2	Front Panel w/Visors	Mode 1 and Mode 2
RGL-8	Lens	Mode 1 and Mode 2
RGL-29	Frangible Column	Mode 1 and Mode 2
RGL-38	Spanner Wrench (optional)	Mode 1 and Mode 2
RGL-21	Constant Current Power Supply	Mode1 constant current
RGL-25	CC On/Off Switch (optional)	Mode1 constant current
34-065666	65 Watt Isolation Transformer	Mode1 constant current
RGL-20	Voltage Power Supply	Mode 2 voltage
RGL-41	Photodiode	Mode 2 voltage
88-4V32	Series Surge Arrestor	Mode 2 voltage
RGL-26	Voltage On/Off Switch (optional)	Mode 2 voltage
RGL-51	Isolation Transformer, 120VAC input	Mode 2 voltage
RGL-52	Isolation Transformer, 240VAC input	Mode 2 voltage

Voltage Style L-804 LED RGL

Item No	Part Number	Description	QTY
1	RGL-14, RGL-15	Vertical Adjust Right, Left	2
2	RGL-41	Photodiode Assembly	1
3	RGL-2	Front Panel	1
4	RGL-4	Mounting Frame	1
5	RGL-30	Tether	1
6	RGL-31	Tether Post	2
7	RGL-5	Column Clamp	1
8	RGL-6	L867 Base	1
9	RGL-29	Frangible Column	1
10	RGL39	1/2 in Elbow	2
11	RGL-18	Light Engine	2
12	RGL-19	Control Board	1
13	RGL-20	Voltage Power Supply	1
14	RGL-51	Isolation Transformer, 120VAC input	1
14	RGL-52	Isolation Transformer, 240VAC input	1

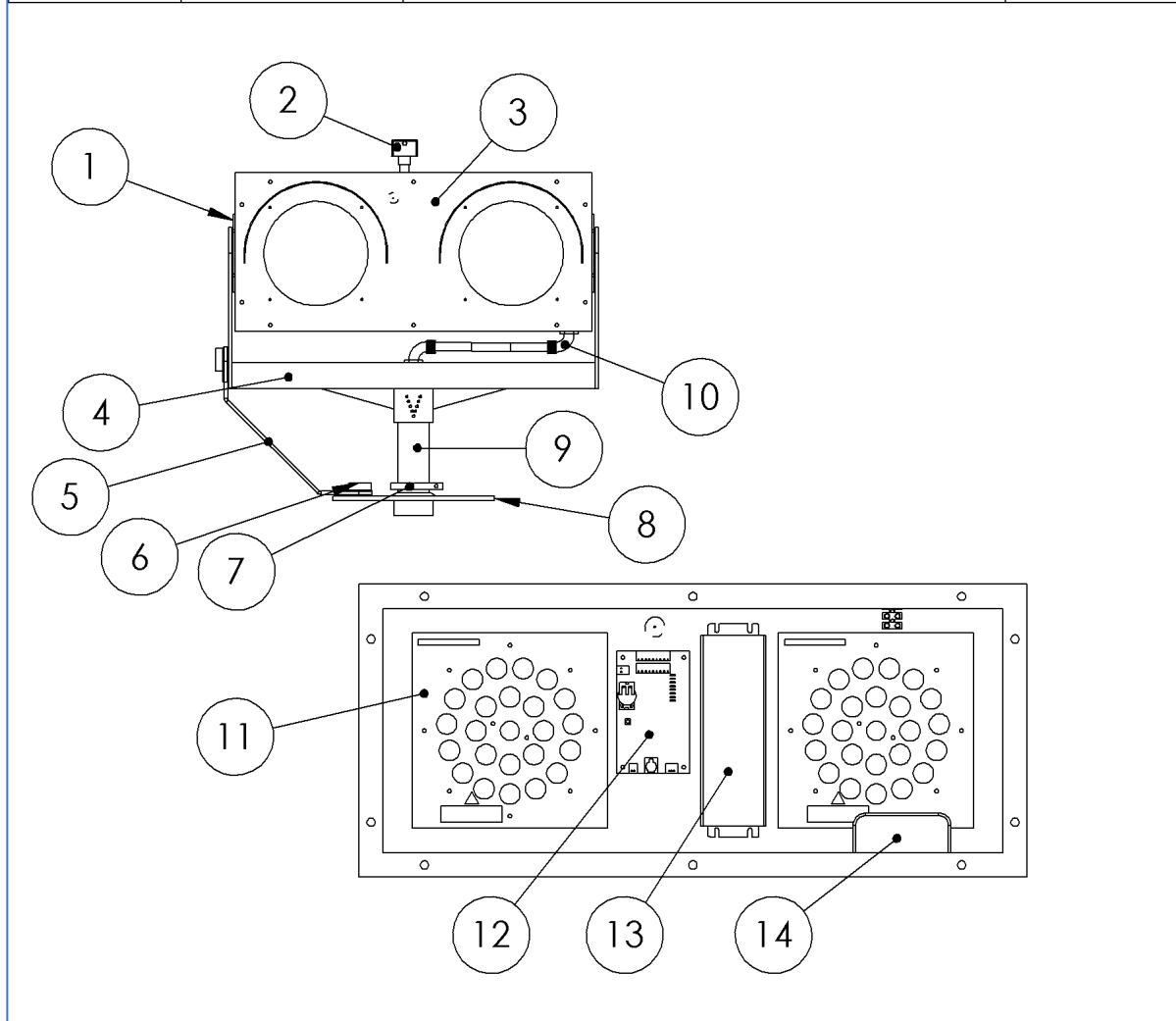

Constant Current Style L-804 LED RGL

ITEM NO.	PART NUMBER	DESCRIPTION	Current Style/QTY.
1	RGL-14, RGL-15	Vertical Adjust Right, Left	2
2	RGL-41	Photodiode Assembly	1
3	RGL-4	Mounting Frame	2
4	RGL-39	1/2 in. 90° Elbow	1
5	RGL-29	Frangible Column	1
6	RGL-5	Column Clamp	1
7	RGL-6	L-867 Base Plate	1
8	RGL-2	Front Panel with Visors	1
9	RGL-3	Back Panel	1
10	RGL-31	Tether Post	2
11	RGL-30	Tether	1
12	RGL-32, 33	Upper Harness 5 Cond, 2 Cond	1
13	RGL-10, 12	Lens Bracket with Adhesive Bumper	8
14	RGL-18	Light Engine	1
17	RGL-19	Control Board	1
16	RGL-21	Current Power Supply	1
17	RGL-24	Bridge Rectifier	1
18	RGL-16	Panel Gasket	1

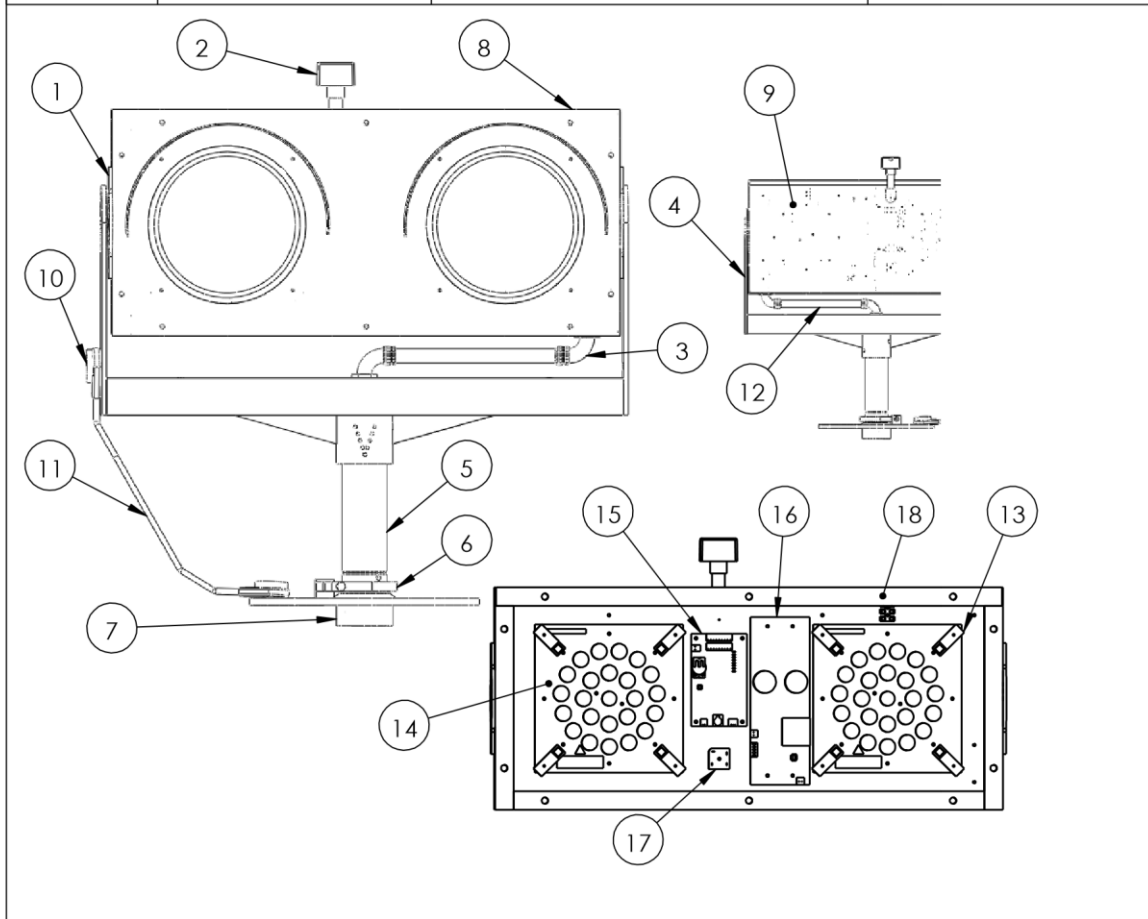
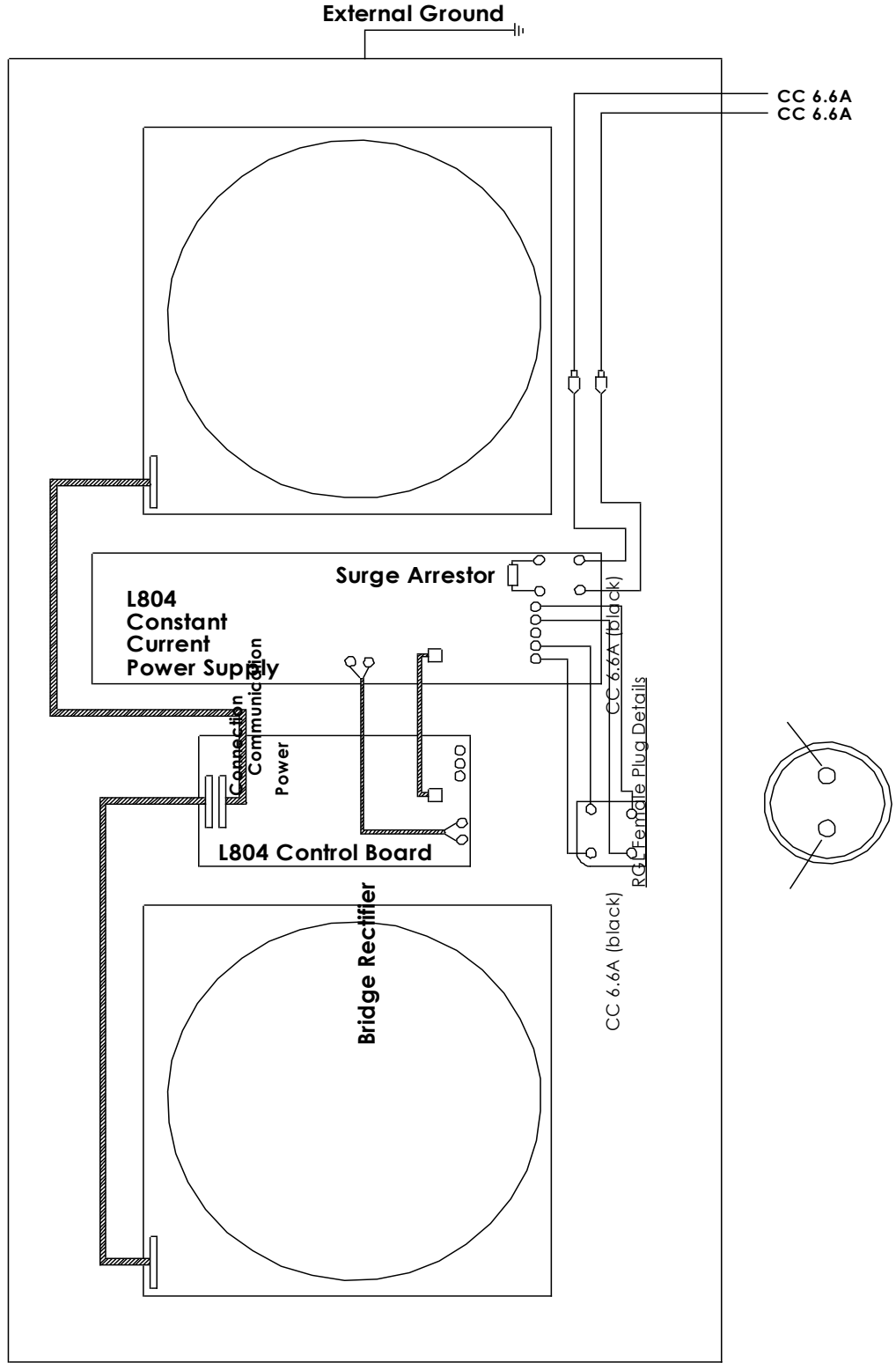

Table 2: Trouble Shooting

<p>Guard Light not seen by external monitor</p>	<p>Continuity can be changed from normally closed to normally open by moving connector on the Controller PCB at Monitor (figure 13)</p>
<p>More than 5 LEDs are out</p>	<p>Restart the guard light. If LEDs are still out when restarted replace Light Engine.</p>
<p>Only 1 Light Engine Flashes</p>	<p>Reboot system. Switch light engine plugs to see if problem follows light engines or the control board. Replace the light engine if the problem follows the light engine. Replace the control board if the problem follows the control board.</p>
<p>Guard light has been knocked down</p>	<p>The broken frangible column threads can be removed from the baseplate with a spanner wrench. Check the upper and lower wire harnesses and replace any harness that has been nicked or damaged. Install a new frangible column.</p>
<p>Does not switch day/night modes</p>	<p>Reboot system. Cover the Photodiode and wait 60 seconds and see if there is any change. Unplug photodiode and place a jumper across the photodiode connector at the control board. If jumper works, replace the photodiode. If jumper does not work replace the control board.</p>

LED Light Engine

LED Light Engine



LED Light Engine

LED Light Engine

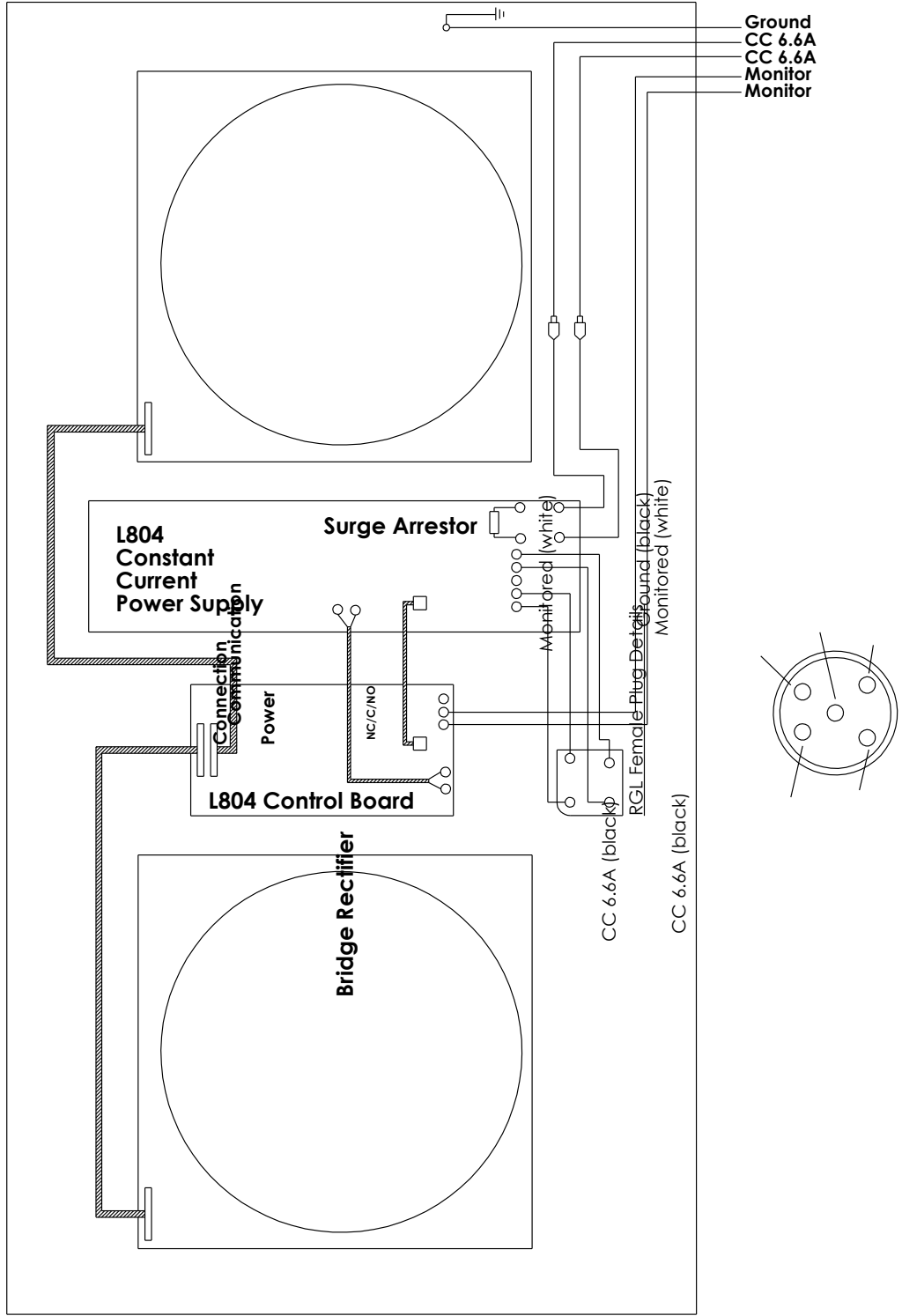

Mode 2 - Parallel Powered

(voltage style - no monitor)

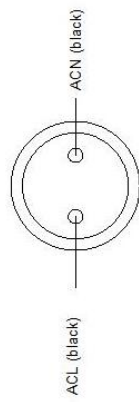
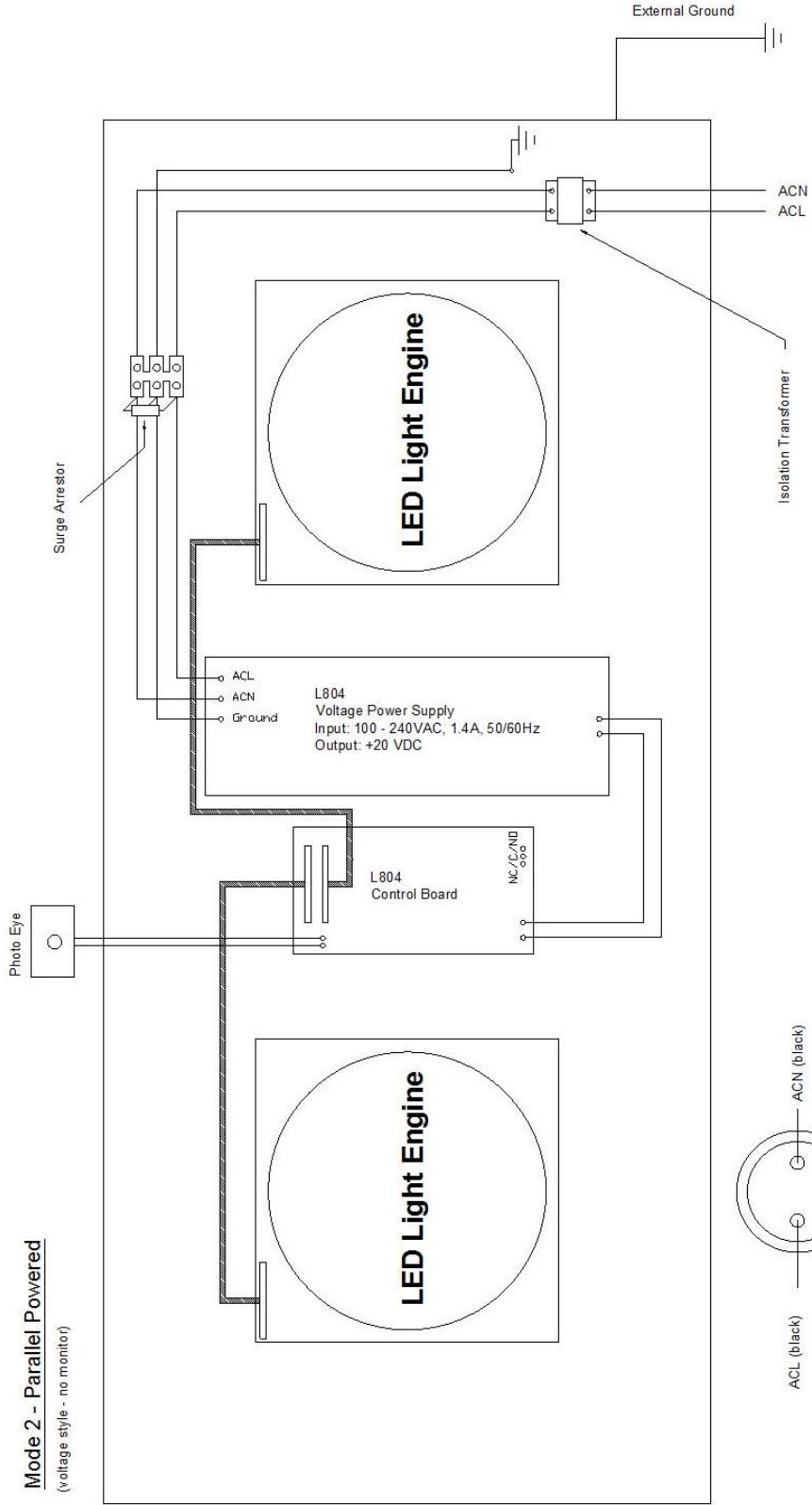

RGL Female Plug Details

Mode 2 - Parallel Powered
(voltage style - monitor)

