

STROBE APPROACH LIGHTING

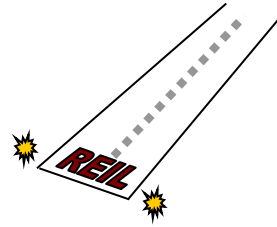

TECHNOLOGY

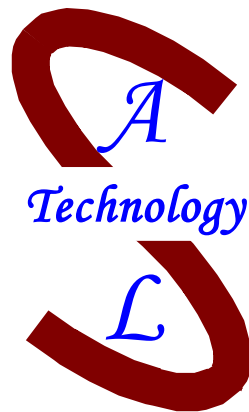

L-849I, STYLE A/C/E
LED CURRENT-POWERED
APPROACH LIGHTING SYSTEM

SAL-1030-I

USER'S MANUAL

STROBE APPROACH LIGHTING TECHNOLOGY™
108 FAIRGROUNDS DRIVE
MAILIUS, NY 13104
315-682-6460

SCOPE

This manual contains Installation, Operation, and Maintenance information for an LED-based L-849I, Style A/E, Unidirectional Runway Approach Lighting system manufactured by Strobe Approach Lighting Technology™ (SAL Technology™) for use in constant-current powered applications. The manufacturer's designation for this equipment is SAL-1030-I REIL System.

CARTON LABELING

The SAL-1030-I REIL System is packaged into a single carton that includes two (2) Head Assemblies, two (2) Junction Boxes, one (1) Master Control Unit (MCU), and three (3) frangible fittings. Some systems may have accessory items that require separate packaging.

UNPACKING

Inspect shipping cartons for external damage immediately upon receipt. There could be damage to the contents if the carton is damaged. Promptly file a claim with the freight carrier if you have received damaged equipment.

TOOLS RECOMMENDED

- #2 Phillips screwdriver; 10-inch shank.
- 3/16-inch, flat blade screwdriver; 10-inch shank.
- Large (3-inch) slip-joint pliers (for pipe and lock nuts)
- Wire strippers.
- Wire cutters (for small gage wire).
- Volt-Ohm meter

ABBREVIATIONS USED IN THIS MANUAL

- CSM → Current Sensing Module
- CCR → Constant Current Regulator
- EMT → Electrical Metallic Tubing
- JB → Junction Box
- LSM → Light System Master (a circuit card)
- MCU → Master Control Unit
- NPS → National Pipe Straight thread (not tapered)
- NPT → National Pipe Tapered thread
- REIL → Runway End Identifier Lights
- SLC → Series Lighting Circuit

DISCLAIMER

The information in this manual is believed to be accurate and up to date, however, Strobe Approach Lighting Technology assumes no liability for damages or injuries that may result from errors or omissions, or from the use of information presented herein. Strobe Approach Lighting Technology reserves the right to modify this manual at its own discretion without notification to any person or organization.

APPLICABLE SPECIFICATIONS

This equipment meets or exceeds the requirements in the FAA Advisory Circular, AC 150/5345-51B, and EB 67D.

WARRANTY

Strobe Approach Lighting Technology™ warrants this equipment and all of its components when used under normal conditions. Failure of any component within one year from the date of shipment will be corrected by repair or replacement, FOB Manlius, NY 13104.

USE OF GENERIC PARTS

Using parts not manufactured or supplied by Strobe Approach Lighting Technology, or unauthorized modification of any part of this equipment, voids the warranty and could render the equipment noncompliant with applicable FAA specifications.

IMPROPER INSTALLATION

This equipment can be damaged if the procedures and recommendations contained herein are not observed during installation. Any damage resulting from incorrect installation will void warranty.

CONTACT INFORMATION

Strobe Approach Lighting Technology may be contacted by the following methods: Tele: 315-682-6460

Email: sales@saltechnology.com

WARNING

Do Not Depend on Interlocks For Safety

Never depend on an interlock switch alone to render the equipment safe. Always turn off and lock out upstream power when performing maintenance on this equipment.

TABLE OF CONTENTS

	Page
Front Matter-----	i-iv
Carton Labeling-----	i
Unpacking-----	i
Tools Recommended-----	i
Abbreviations Used in This Manual-----	i
Applicable Specifications-----	ii
Warranty-----	ii
Use of Generic Parts-----	ii
Contact Information-----	ii
Table of Contents-----	iii
List of Figures-----	iv
General Description-----	1
Equipment Specification-----	2
Installation-----	3-12
Emplacement Preparations-----	3
Recommended Sequence of Steps-----	3
Equipment Access-----	3
The Master Control Unit-----	4
Preventing Condensation-----	5
The Optical Heads-----	6
Zeroing and Aiming-----	7
System Wiring-----	8-11
Wiring at the Master Control Unit-----	9
Wiring at the Junction Boxes-----	10-11
Lightning Protection-----	12
Functional Description-----	14
Theory of Operation-----	14
Operating Instructions-----	15-18
Status Monitoring-----	16
Setup with a 3-Step CCR-----	17
Setup with a 5-Step CCR-----	18
Troubleshooting-----	19
Maintenance-----	20
Replaceable Parts-----	21

LIST OF ILLUSTRATIONS

PAGE

1a: Optical Head -----	1
1b: Master Control Unit -----	1
1c: System-----	1
2a: MCU Mounting Details -----	4
2b: Co-located MCU-----	4
3: Head Mounting Details -----	6
4: Electrical Overview -----	8
5: MCU Input Terminal Block -----	9
6: MCU Output Terminal Block -----	9
7: Junction Box At Station A-----	10
8: Junction Box at Station B -----	11
9: System Grounding (Lightning Protection) -----	12
10: Control Module-----	16
11: Current Sensing Module-----	17
12: Component Location Diagram-----	21
A-1: System Configuration-----	A-1
A-2: MCU Wiring Diagram-----	A-2
A-3: Junction Box-A Wiring Diagram-----	A-3
A-4: Junction Box-B Wiring Diagram-----	A-4
A-5: Optical Head Assembly Wiring-----	A-5

GENERAL DESCRIPTION

The SAL-1030-I is a current-powered REIL System consisting of two Light Units and a Master Control Unit (MCU). Each Light Unit is made up of an Optical Head and a Junction Box. The heads and junction boxes may be separated for shipment and required to be mechanically and electrically connected during installation. The Junction Boxes provide convenient locations for electrical connections without having to access the Optical Heads.

The MCU is a separate unit (Figure 1b) that is electrically connected to the two Junction Boxes. The MCU and one of the Head/Junction Box assemblies may optionally be co-located on one side of the runway, deriving power from a single (shared) L-830-4 (100 watt) isolation transformer. This would be considered as the Master station.

The SAL-1030-I Style A/E has three flash intensity levels and may be set up to switch automatically from one to another as a function of the input CCR current level, or it may be set up to flash at only one or two of the three available intensity levels. Style C has one intensity that may be set to engage at desired CCR levels.



Fig. 1a
Optical Flash Head



Fig. 1b
Master Control Unit (MCU)



Fig. 1c
SAL 1030-I System
(Second flash head not shown)

EQUIPMENT SPECIFICATION

PHYSICAL: Dimensions are in inches (mm); Weight in lbs (kg).

Master Control Unit (Figure 1a).

Dimensions ----- 6.5H x 13.5W x 12D (165 x 343 x 305)

Weight: ----- 10.2 (4.6)

Optical Head (Figure 1b).

Dimensions ----- 15H* x 15W x 4.8D (381* x 381 x 122)

Weight: ----- 24.6(11.2)

*Height is overall-See Figure 3.

Junction Box (Figure 1c).

Dimensions: ----- 7.9 x 9.0W x 4.5D (201 x 229 x 114)

Weight: ----- 8.8 (4.0)

OPERATIONAL:

Current (rms) ----- 2.8 to 6.6 Amps, 50/60 Hz

Power: (Watts) ----- 50

Flashes Per Minute ----- 120

Intensity: (Effective Candelas*, total beam spread) High: 7500 to 22500

Med: 750 to 2250

Low: 150 to 450

Beam Spread: ----- 30° Horizontal, 10° Vertical.

INSTALLATION

In this section you will find instructions and recommendations for the following:

- Emplacement preparations.
- Installation sequence.
- Accessing the various components of the system.
- Mounting the Master Control Unit (MCU).
- Mounting the Junction Boxes.
- Mounting the Optical Heads
- Zeroing the Horizontal Aiming Scales.
- Zeroing the Vertical Scales and Pointers.
- Electrical connections.

Emplacement Preparations

Two mounting configurations are available for an SAL 1030-I LED REIL system. Three mounting emplacements are required if all three major assemblies are mounted separately. However, only two emplacements are required if one Optical Assembly is co-located with the Master Control Unit (MCU). Regardless of which configuration is used, each major assembly is supported by a mounting column that must be affixed to a secure mounting base with a threaded fitting such as a floor flange bolted to concrete, or a threaded light base cover. If a light base cover is used for co-located units it must have two threaded holes on 8-inch centers.

The system is shipped with compression fittings for 2-inch diameter EMT supporting columns. The lower fittings provided are frangible couplings with pipe threads on one end.

Co-located components are depicted in Figure 2b. Mounting columns are typically site dependent and therefore not normally shipped with the equipment unless by special order.

Detailed drawings for the emplacement foundations are furnished by others.

Recommended Sequence of Steps (Abbreviated)

- Install the Junction Boxes at the prescribed light positions.
- Zero the Horizontal Scale at each light emplacement.
- Install each Optical Head onto its Junction Box with the Horizontal Pointer at the prescribed offset angle (obtained from site drawings).
- Level the Optical Head and Zero the Vertical Pointer.
- Set the prescribed elevation angle at each head.
- Install the Master Control Unit (may be done at any point in the sequence).
- Make electrical connections.

Equipment Access

- The cover to the MCU is secured by quarter-turn latches with padlock provisions on the two front corners of the enclosure.
- Each light emplacement has an Optical Head and Junction Box.
- Each Junction Box has a removeable cover secured by captive screws at each corner.

Optical Heads do not have to be accessed for installation.

INSTALLATION (cont.)

The Master Control Unit (See Figure 2)

The Master Control Unit (MCU) is provided with a factory-installed compression fitting for 2-inch EMT at the bottom surface of the enclosure. The EMT (normally provided by others) serves as a supporting column. When co-located, a length that places the top surface of the control cabinet approximately at the height of the optical head is recommended (see Figure 2b). A threaded frangible coupling is provided to secure the supporting column to a threaded ground fixture such as a floor flange bolted to a concrete base, or a threaded light-base cover.

Figure 2a shows how the MCU could be mounted when it is located separately from either Optical Head.

Figure 2b shows how the MCU could be mounted adjacent to one of the light units (co-located) on a base with two threaded holes on 8 inch centers.

Mounting details for the light units (whether separate or co-located) are shown in Figure 3.

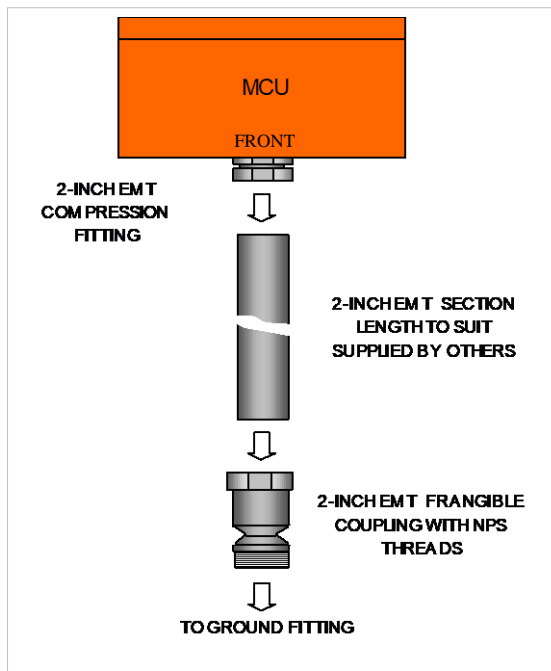

Figure 2a
MCU Mounting Details

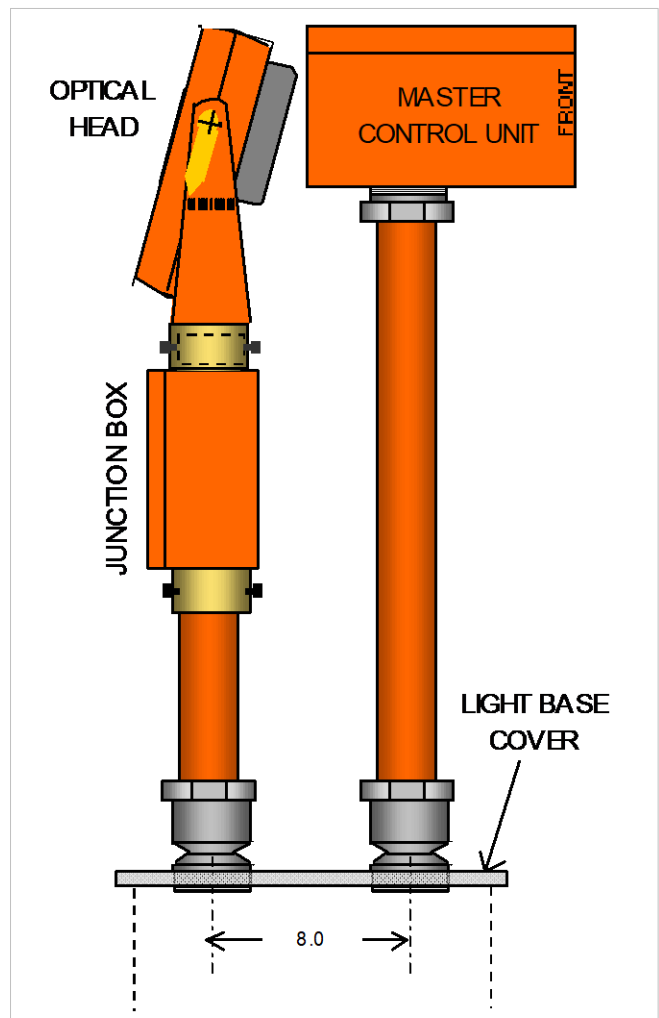

Figure 2b
Co-located Mounting

PREVENTING CONDENSATION

When equipment in an enclosed volume located above ground is connected by conduit to a volume located in the ground there could be free exchange of air between the two volumes as a result of differing temperatures. This could lead to the formation of condensation, particularly on the inside walls of the above ground enclosure and to components within the enclosure under certain conditions of atmospheric temperature and humidity. This could apply to the MCU and Junction Boxes that are supported by EMT or any other similar type of support.

Electrical connections between in-ground components and components within the above ground enclosures require passing wires through the supporting column. Therefore, foam plugs, slotted to allow the passage of wires, are shipped with the equipment. The slotted foam plugs, when pressed into the entrance hole to the MCU, close tightly around the wires and prevent the free exchange of air between the two volumes.

The entrance hole to a Junction Box is much smaller, and not as easily closed off by a foam plug. A pliable material such as Gardner-Bender DS-110 Duct Seal could be used effectively.

Failure to install plugs or to provide other means of preventing free air exchange will void the equipment warranty.

INSTALLATION (cont.)

The Optical Heads

Junction boxes and Optical Heads may be shipped unattached to be assembled during installation. The first step is installing the Junction Box onto its mounting column before the Optical Head is attached.

Parts needed for this procedure (at each emplacement):

- Optical Head
- Junction Box
- 2-inch, EMT supporting column:
 - > Length determined by site requirements
 - > Not furnished with equipment
- Frangible coupling (with compression fitting)

Installation overview

The Optical Heads are mounted onto Junction Boxes and located on each side of the runway near the runway threshold. Location details are typically obtained from drawings provided by others.

Each Junction Box is supported by a single section of 2-inch EMT and various couplings as shown in Figure 3. The length of the EMT will generally be different from site to site; therefore it is not furnished with the equipment. The length is usually chosen to achieve a certain overall height above grade as called out on site drawings provided by others.

The MCU and one of the light units may be co-located at an emplacement that has two threaded receivers separated by 8 inches (203 mm) center-to-center. This would be considered as the Master station. The installation details are the same for both heads even if the MCU is co-located with one of the heads as shown in Figure 2b.

Mounting and Assembly Details (Refer to Figure 3)

Use the following procedure as a guide:

- Install the frangible coupling onto the ground attachment device (typically a light base cover or a threaded floor flange bolted to a concrete pad).
- Install the EMT supporting column, and securely tighten the compression fitting.
- Set the Junction Box onto the upper end of the EMT and lightly tighten the two hex-head bolts. Firm tightening will be done later during the aiming procedure.

It is not necessary to turn the setscrew. It has been properly set at the factory.

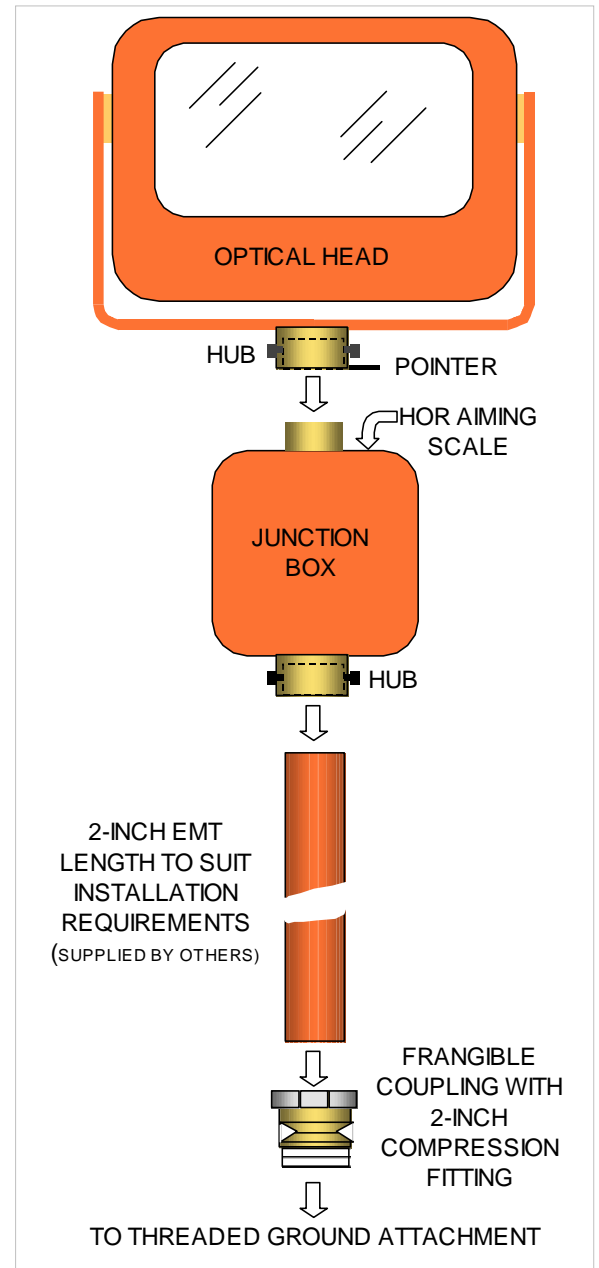

Fig 3
Typical Head Mounting Details

INSTALLATION (cont.)

Zeroing and Aiming Instructions

Horizontal

Optically enhanced LEDs, unlike conventional light sources, have very sharply defined beams; aiming is therefore very critical. A horizontal scale has been provided to assist in aiming, but it must be properly aligned with the runway in order to use it effectively. Horizontal scale alignment (zeroing) can be performed before setting the Optical Head onto the Junction Box.

The horizontal scale is attached to the top surface of the Junction Box. The scale ranges from -15° to $+15^{\circ}$ in increments of 1° . A pointer affixed to the Optical Head assembly indicates the aiming direction of the head, but first, the scale must be accurately referenced to the runway. This requires orienting the Junction Box to face exactly downrange; that is, parallel to the centerline of the runway. This can be achieved by following the steps below:

- Establish an aiming target such as a stake or a person placed the same offset distance from the runway centerline as the light emplacement. The target should be at least 200 feet down-range from the emplacement.
- Use a top edge of the Junction Box as a sighting line and rotate the Junction Box about its supporting pipe until the edge points directly towards the target.
- Securely tighten the hex-head bolts when the Junction Box is aligned with the aiming target. The cone-point setscrew prevents the Junction Box from turning while the bolts are being tightened. The horizontal scale is now referenced to the runway.
- Install the Optical Head onto the Junction Box by setting the hub over the mounting post on the top surface of the J-B.
- Lightly tighten the hub's two hex-head bolts.

It is not necessary to turn the setscrew. It has been properly set at the factory.

- Rotate the head until the pointer rests on the horizontal offset angle defined for this emplacement and firmly tighten the two hex-head bolts.

Vertical

The head is secured vertically by a zero-backlash turnbuckle. The head is tilted by turning the body of the turnbuckle. In normal operation the head will be pointing somewhat upwards; that is, above the horizon. *You should avoid tilting the head to point below the horizon because the turnbuckle end-fittings can become disengaged which would allow the head to swing freely on its pivots.* You will use the spirit level residing in a cavity just above the vertical pointer to zero the vertical scale before the tilt angle is set in.

To zero the vertical pointer:

- Rotate the body of the turnbuckle until the level bubble lies symmetrically between its two reference lines.
- Loosen the screw that holds the vertical pointer and set the pointer to 0° on the scale.
- Tighten the screw while the pointer rests on zero.
- Use the turnbuckle to set in the vertical aiming angle prescribed for this emplacement.

This completes mounting and aiming

INSTALLATION (cont.)

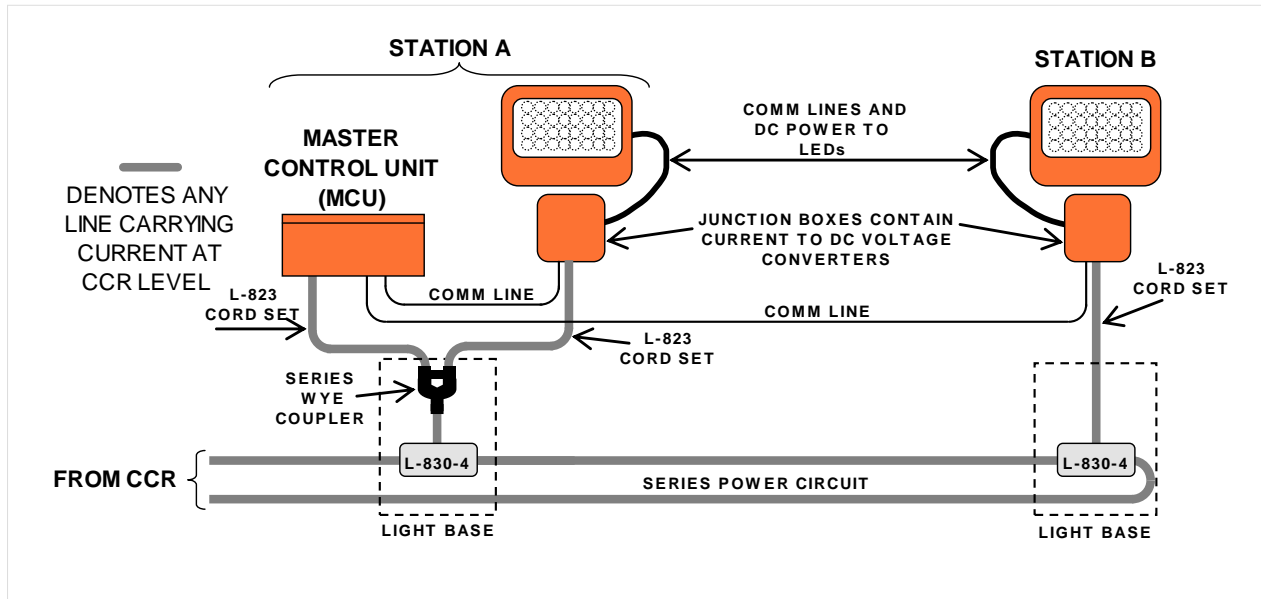

Fig 4
Electrical overview

System Wiring

Installation wiring consists of making electrical connections for power and communications (Comm). All connections are made at terminal blocks that accept bare-wire insertions under screw clamps. No special wire terminations or tools are required.

Figure 4 depicts the generalized wiring scheme for a two-emplacement installation in which one of the light units is co-located with the MCU. Each light station is connected to a series lighting circuit through an L-830-4 Isolation Transformer. The MCU and one light unit reside at the A-station. This is considered to be the Master station. The L830-4 transformer at Station A provides power for both the MCU and the co-located Optical Head through the use of a series wye coupler.

The wiring is similar if the MCU is mounted separately at a remote location, but it would have its own L-830-4 isolation transformer in that case.

L-823, two-wire, cord sets are pre-attached at the factory. Two cord sets are furnished for Station A. The cord set for Station B is part of the Station B Junction Box.

Comm wiring must satisfy the requirements for an EIA RS-485 data bus. The Comm cable must have an overall shield and at least three conductors. Two of the conductors must be a twisted-shielded pair for balanced-line data transmission (designated as Comm A and Comm B). The third conductor is an *isolated* ground conductor that must not be twisted in with Comm A and Comm B. The isolated ground connection is designated as **CGi** at the terminal blocks.

Do not connect the CGi conductor to chassis ground.

For separation distances typically encountered in REIL installations (< 500 ft) a shielded cable consisting of two twisted, shielded pairs is generally acceptable. One twisted pair would be used for Comm A and Comm B as described above; the other twisted pair could be tied together as one conductor and used for the CGi function. Use Belden 3106A or 3107A, or an equivalent cable.

INSTALLATION (cont.)

Wiring at the MCU

TB101 is the *input* terminal block for Primary Power. See Figure 5.

- Power is applied to the MCU through a pre-attached L-823 cord set connected to positions labeled A & B.
- An L-830-4 Isolation Transformer supplies power for both the MCU and the co-located light at Station A. Driving two isolated loads from a single transformer requires a series circuit wye fitting as indicated in Figures 4 & 7.

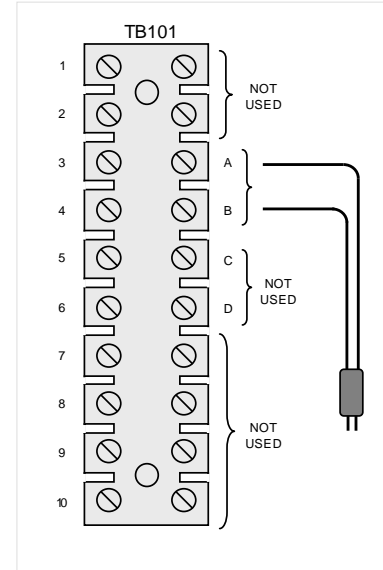

Fig. 5

MCU Input Terminal Block

TB102 is the *output* terminal block. See Figure 6.

It provides connections for communications to both Optical Heads through their respective Junction Boxes.

An RS-485 compatible cable with AWG 22 (min) wire such as Belden 3106A or 3107A is required as a Comm cable running between the MCU and Station B. A short length of the same cable may be used between the MCU and the co-located Station A light. This cable is not normally provided with the equipment.

A low capacitance, shielded cable with two twisted pairs may be used in lieu of the Belden cable mentioned above. In this instance the two conductors of the second twisted pair would be tied together and used as a single conductor for the CGi connection.

The RS 485 data transmission signal is phase-sensitive; therefore a line originating as Comm “A” at the MCU must be connected to Comm “A” at its designated Junction Box.

Optical Heads are identified as #1 and #2 (Station-A & Station-B) at the MCU output terminal block (TB102). Observe and follow the labeling to ensure proper head addressing for automatic data logging.

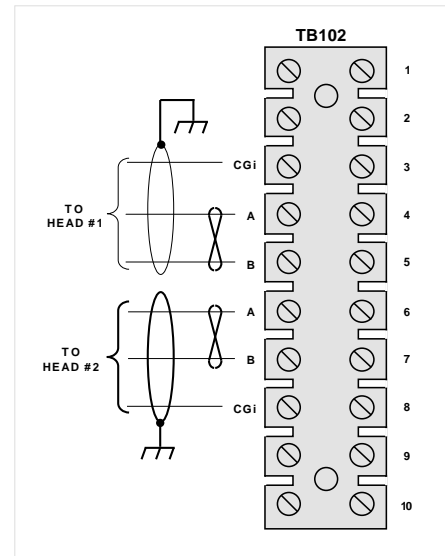

Fig. 6

MCU Output Terminal Block

Do not connect CGi to chassis ground.

INSTALLATION (cont.)

Wiring at the Junction Boxes

Junction Boxes contain alternating current-to-rectified voltage (ac to dc) converter modules, and terminal blocks to which power and signal conductors are attached during installation. Wiring during installation consists of connecting power and Comm conductors as indicated in Figures 7 and 8. Power is derived from a constant-current series circuit through an L-830-4 Isolation Transformer at each Light Station. A series wye connector at Station-A permits powering the MCU and the Station-A light fixture from the same transformer.

Twisted, shielded conductors connect the MCU to the Junction Boxes for communications. A five-conductor, color-coded harness carries communications and dc power from each Junction Box to its associated Optical Head as implied earlier in Figure 4. These head harnesses are encased in metallic, weather-tight, flexible conduits that are pre-attached at the Optical Heads. The free end of each head cable must be attached at TB201 in the Junction Box during installation following color-coded information at the terminal block. The head at Station-A is arbitrarily designated as Head #1 in these instructions.

Junction Box housings must be attached to a grounding stake as shown in Figure 9.

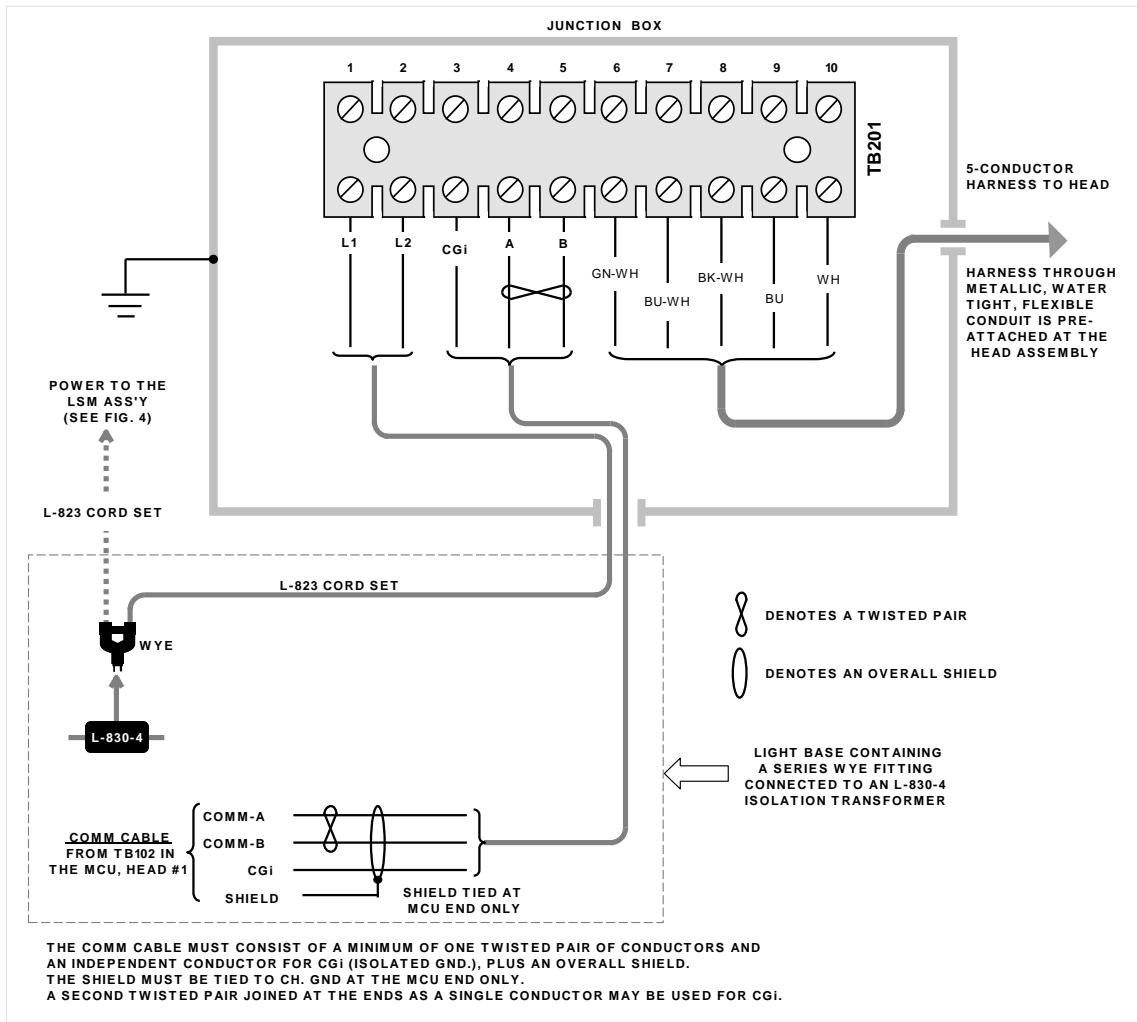

Fig. 7
Junction Box at Station A

INSTALLATION (cont.)

Wiring at the Junction Boxes (cont)

The electrical connections at the remote Station-B are shown in Figure 8.

These connections are similar to those described for Station A, but the ac power originates directly from a local L-830-4 Isolation Transformer via an L-823 cord set.

Output connections to the head are the same as those already described for Station-A.

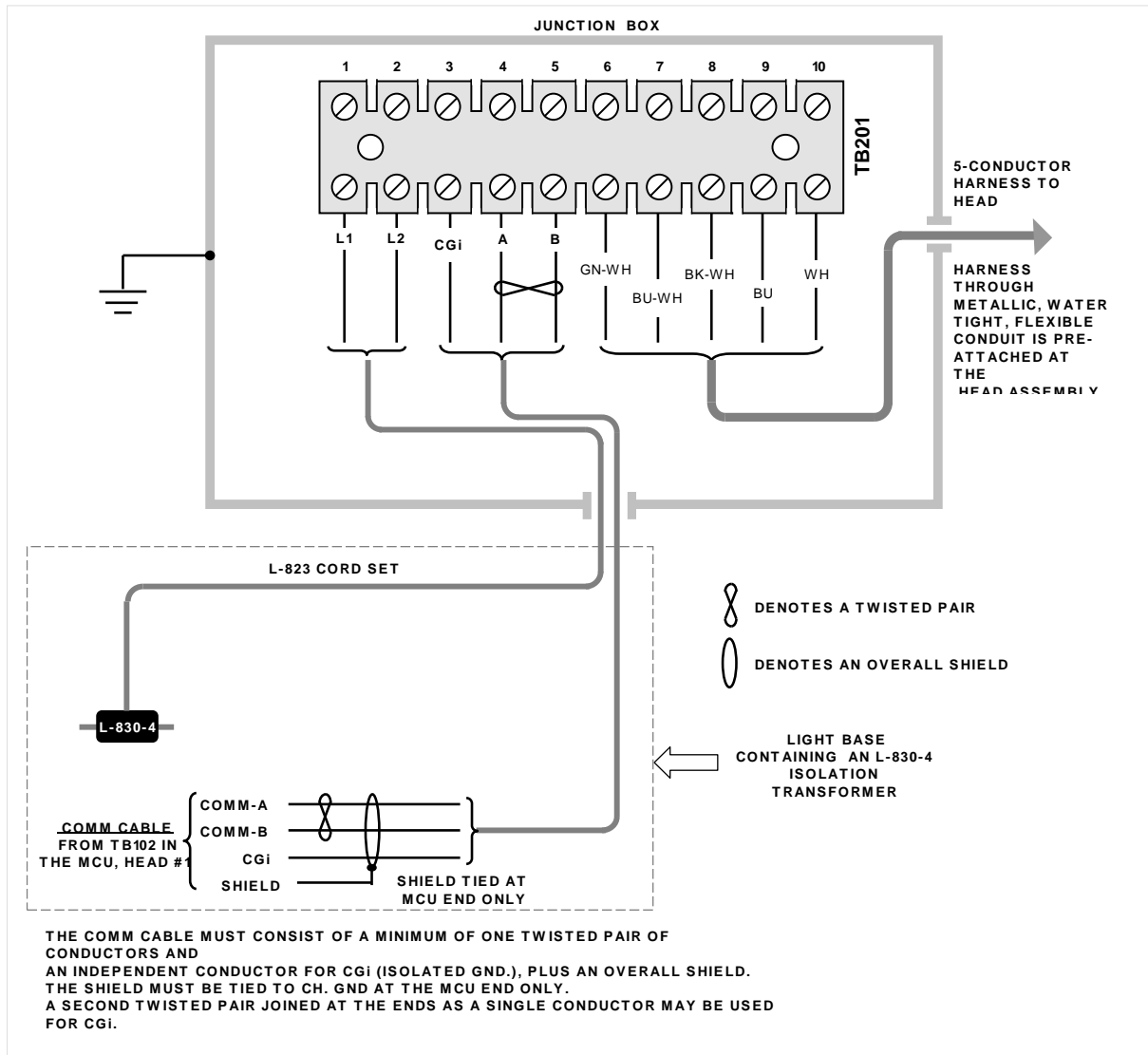

Fig. 8
Junction Box at Station B

INSTALLATION (cont.)

Lightning Protection

System grounding and lightning protection must be maintained as two different electrical circuits that should never be interconnected. Grounding is part of the system's internal signal circuit that may be carried (if necessary) from one light unit to another. Lightning protection is an external connection to local earth.

This system derives its power from Isolation Transformers and is thus not referenced to earth through the source of power. The communication lines are also isolated and not referenced to ground. Thus each station is electrically isolated by design, but it is necessary to provide a grounding rod at each location in order to achieve satisfactory lightning protection. The grounding rod is connected to metallic housings or to internal metallic structures as depicted in Figure 9.

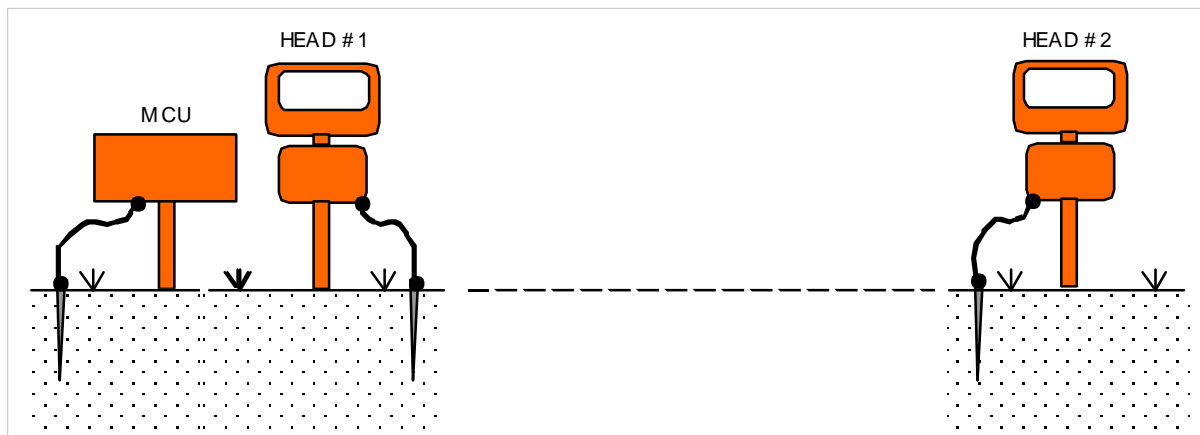

Fig. 9

GROUNDING THIS EQUIPMENT TO A COUNTERPOISE CONDUCTOR COULD INCREASE THE RISK OF LIGHTNING DAMAGE

THIS COMPLETES INSTALLATION INSTRUCTIONS

FUNCTIONAL DESCRIPTION

The SAL 1030-I REIL is a Style A/C/E, current-powered system consisting of two Optical Heads and a Master Control Unit (MCU). Each head has an associated Junction Box that contains an alternating current-to dc voltage converter.

The heads receive flashing and other operating commands from the MCU and send operating status information back to the MCU in return. Certain operating parameters can be selected to be shown visually on a four-digit numerical display. See Figure 10. The numerical display will also automatically display Error Codes if they should occur. Error Codes are displayed alternately with the selected parameter display. The default display parameter is operating hours at High intensity. LED voltage or temperature may instead be selected for display.

Operation is typically automatic, but flash intensity functions can be set in manually for checkout purposes. The two Optical Heads flash simultaneously upon a single command from the MCU. Programming set in at the factory controls flash rate (120 flashes per minute).

The light beam is slightly greater than 10° vertically by 30° horizontally. This beam coverage is formed by the composite effect of an array of high-performance, white LEDs.

The array is monitored in such a way that a failure of a complete row or column, or a combination that exceeds a certain number of LEDs at random locations, will turn on an alarm signal light and cause an alarm relay to operate. Alarm relay contacts are available for external distribution.

THEORY OF OPERATION

The SAL 1030-I REIL is a micro-controller based system consisting of two Optical Heads and a Master Control Unit (MCU). Each Optical Head consists of an array of 60, optically enhanced, high performance, LEDs arranged geometrically to form beam coverage of at least 10° vertically, and 30° degrees horizontally.

The MCU has a single micro-controller card (PCB101, LSM card) for all input and output functions. An RS-485 data bus provides communications between the MCU and the Optical Heads. A micro-controller card in each head communicates with the LED arrays in that head, collecting status information to send back to the LSM card in the Master control Unit. Each head is identified by an address code for data tagging at the MCU.

A low-capacitance data transmission line, suitable for RS-485 drivers and receivers, can support satisfactory communications at the baud rate of this system for up to 4000 feet.

While the heads communicate only with the MCU, the MCU has connections outside of the system such as primary power, remote control, and a remote alarm circuit. These lines may be subjected to voltage surges or other electrical disturbances. They are therefore provided with over-voltage protection within the MCU. Similar surge protection guards the RS-485 data bus to the Optical Heads.

The MCU is powered by a 24 Vdc switchmode power supply driven by constant current from 2.8 to 6.6 amperes (rms) from a CCR.

Each Optical Head is powered by a 50 Vdc switchmode power supply located in a Junction Box (part of each head emplacement).

The Head Controller cyclically scans the LED array collecting temperature, voltage, and flash information. An alarm signal is generated if either head develops an operating condition that falls below a prescribed safe level (EB67D). Examples are: more than 12 (20%) failed LEDs in a single head, or an incomplete column or row of LEDs. A fail-safe Alarm Relay that can be used for remote alarm signaling is also activated.

OPERATING INSTRUCTIONS (See Figure 10)

Controls

Each sub-assembly has an interlock switch that interrupts primary power when the cover is opened. These switches also have an override feature for service convenience.

There are two additional switches in the MCU for operating control:

The MODE CONTROL rotary switch (SW102) selects operating modes, manual or automatic (remote).

The INDEX pushbutton switch (SW103) selects parameters for the four-digit numerical display.

The operating modes from SW 102 are:

- REM (Remote)
- Off
- MAINT (Maintenance)
- LOW
- MED (Medium) (Style A/E Only)
- HIGH (Style A/E Only)

Use REM to control flash intensity from CCR current level (via the Current-Sensing Module).

Use OFF to inhibit flashing while the system is energized.

Use MAINT to operate the heads in a low-level, steady (non-flashing) mode (May help to identify the location of a non-operating LED).

Use LOW to flash the LEDs at Low intensity.

Use MED to flash the LEDs at Medium intensity.

Use HIGH to flash the LEDs at High intensity.

Depressing the INDEX switch cycles the status LEDs and the data displayed on the numerical LED array.

VOLTS: When lit the numeric array displays the average voltage across each group of 12 LEDs in both heads combined.

TEMP: When lit the numeric array displays the average operating temperature of the LEDs in both Optical Heads combined.

HOURS: When lit the numeric array displays the total no-fault operating hours at HIGH intensity.

To activate the system when the cover to the MCU is open and primary power is applied:

- Pull up the stem of the SW101 Interlock Switch (Service mode).
- Turn the Rotary Switch to any of the positions below:
 - > MAINT (Maintenance)
 - > LOW
 - > MED (Medium) (Style A/E Only)
 - > HIGH (Style A/E Only)
 - > REM (Remote)

To activate the system for Normal Operation:

- Place the Rotary Switch in the REM position.
- Close the cover
- Apply primary power (CCR)

OPERATING INSTRUCTIONS (cont)

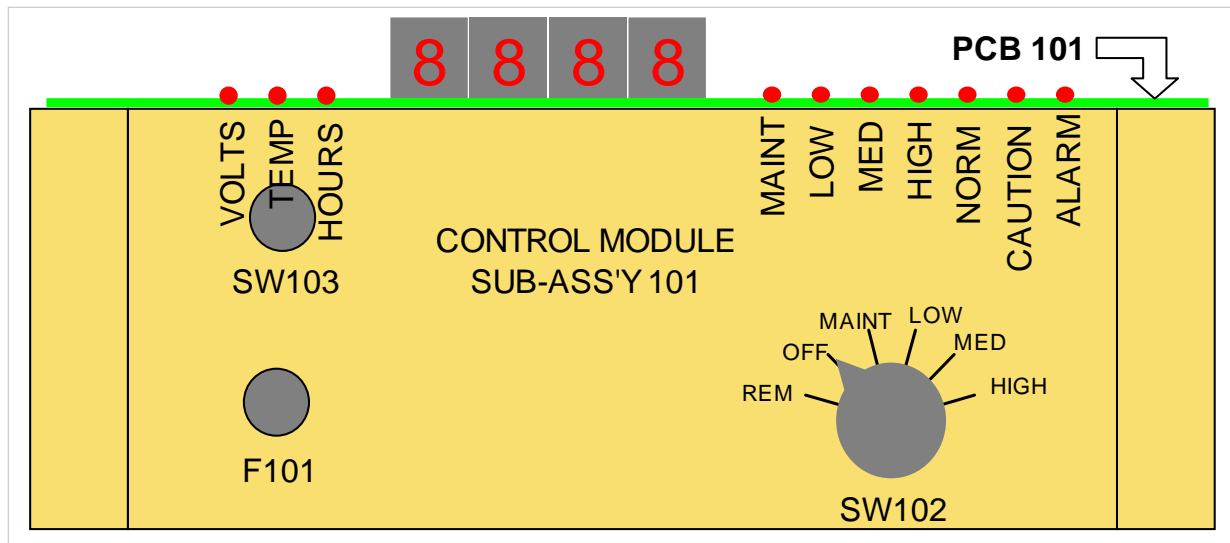

Figure 10
Control Module

Status Monitoring

The default display parameter when power is applied to the MCU is High Mode Hours. If an Error is detected the display will alternate between an Error Code (or Codes) and the selected display parameter (VOLTS, TEMP, or HOURS).

There are two LEDs for critical status monitoring.

CAUTION: This LED lights when an abnormal, but not disabling, condition exists. It signals attention for further investigation into the condition and its cause. Examples are:

- More than 2 LEDs have failed (composite of both heads).
- Temperature has been reported to be more than **80 °C**.
- LED voltage has been reported as below **28 Vdc**.

See the troubleshooting section for recommended actions if any of these conditions arise.

ALARM: This LED lights and an ALARM relay operates (de-energizes) when a disabling condition has developed. Examples are:

- More than **12** LEDs fail to flash or report in either head.
- One head is not reporting.

See the troubleshooting section for recommended actions if any of these conditions arise.

Additional status LEDs indicate various active conditions. Refer to Figure 10.

- **VOLTS:** When lit, the numeric display is the voltage across a series string of 12 LEDs.
- **TEMP:** When lit the numeric display is the average LED operating temperature in °C.
- **HOURS:** When lit the numeric display is HIGH mode operating hours.
- **MAINT:** Indicates that the LEDs are on steady (at reduced intensity).
- **LOW:** Blinks at flash rate when LEDs flash at LOW intensity.
- **MED:** Blinks at flash rate when LEDs flash at Medium intensity.
- **HIGH:** Blinks at flash rate when LEDs flash at High intensity.
- **NORM:** On steady when all operating conditions are normal (no Error Codes).

SET UP INSTRUCTIONS

This equipment is powered by current from a CCR, and derives flash intensity commands based on the level of the CCR current. Potentiometer adjustments are necessary in order to associate specific flash intensities with specific levels of current. These adjustments are made at the current-sensing card (PCB301) depicted in Figures 11 and 12.

The basic CCR is a type L-828, Class 1 (6.6 amps). In this class there are two styles:

- Style 1 (3-step).
- Style 2 (5-step).

Setting up for 3 intensities from a 3-step CCR (Style E)

- Open the cover of the MCU and set the interlock switch (SW101) to the Service Position (pull up).
- Turn all three potentiometers on PCB102 fully counter-clockwise (CCW).
- Set the Mode Switch (SW102) on the Control Module to REM.
- Set the CCR to Step 1.
- Adjust the LOW pot (on PCB102) slowly clockwise (CW) until the adjacent LED turns on.
> The LED marked LOW on the LSM card (PCB101) should begin blinking, and the system should be flashing at Low intensity.
- Set the CCR to Step 2.
- Adjust the MED pot slowly CW until the adjacent MED LED on the CSM card turns on.
>The LOW LED on PCB102 should remain on.
>The LED marked MED on PCB101 should begin blinking, and the LOW LED should turn off.
> Flash intensity should be noticeably brighter than LOW.
- Set the CCR to Step 3.
- Adjust the HIGH pot slowly clockwise until the adjacent HIGH LED on the CSM card turns on.
> The MED & LOW LEDs on PCB102 should remain on.
> The HIGH LED on PCB101 should begin blinking; LOW & MED should be off.
> Flash intensity should be significantly brighter than MED.
- Run the CCR back down through the Steps while observing automatic intensity mode changes.
- Re-adjust any potentiometer if necessary.

Setting up for a single intensity from a 3-step CCR (Style A/C)

The procedure below applies to single HIGH intensity operation. It would be similar if the single intensity were MED or LOW.

- Open the cover of the MCU and set the interlock switch (SW101) to the Service Position (pull up).
- Turn the LOW and MED potentiometers on PCB102 fully counter-clockwise (CCW).
- Turn the HIGH potentiometer fully clockwise (CW).
- Set the Mode Switch (SW102) on the Control Module to REM.
- Set the CCR to Step 3.
- Adjust the LOW pot on PCB102 slowly CW until the adjacent LED turns on.
>The HIGH LED on PCB102 should also illuminate.
>The MED LED on PCB102 should remain off.
>The HIGH LED on PCB101 should begin to blink.
- Set the CCR back to Step 2.
>The HIGH & MED LEDs on PCB102 should turn off.
>The mode indicating LEDs on PCB101 should be off.
- Re-adjust the LOW potentiometer on PCB102 for the turn-off condition if necessary.

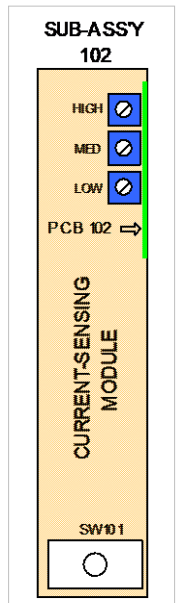

Figure 11
Current
Sensing
Module

SETUP INSTRUCTIONS (cont)

Setting up for 3 intensities from a 5-step CCR (Style E)

- Open the cover of the MCU and set the interlock switch (SW101) to the Service Position (pull up).
- Turn all three potentiometers on PCB102 fully counter-clockwise (CCW).
- Set the Mode Switch (SW102) on the Control Module to REM.
- Set the CCR to Step 1.
- Adjust the LOW pot (on PCB102) slowly clockwise (CW) until the adjacent LED turns on.
 - > The LED marked LOW on the LSM card (PCB101) should begin to blink and the system should be flashing at LOW intensity.
- Set the CCR to Step 2.
 - >Do not make any potentiometer adjustments.
 - >The LOW LED on PCB102 should remain on.
 - >The LOW LED on PCB101 should remain on.
 - > The system should continue to flash at LOW intensity.
- Set the CCR to Step 3.
- Adjust the MED pot slowly clockwise until the adjacent MED LED on PCB102 turns on.
 - >The LOW LED on PCB102 should remain on.
 - >The LED marked MED on PCB101 should begin blinking and the LOW LED should turn off.
 - > System flash intensity should be noticeably brighter than at LOW intensity.
- Set the CCR to Step 4.
- >Adjust the HIGH pot slowly clockwise until the adjacent HIGH LED on PCB102 turns on.
 - >The MED & LOW LEDs on PCB102 should remain on.
 - >The HIGH LED on PCB 101 should begin to blink.
- Set the CCR to Step 5.
 - >Do not make any potentiometer adjustments.
 - >The High, MED, & LOW LEDs on PCB102 should remain on.
 - >The HIGH LED on PCB101 should continue to blink.
- Run the CCR back down through the Steps while observing automatic intensity changes as indicated by the status LEDs, and make any necessary potentiometer re-adjustments.

Setting up for a single intensity from a 5-step CCR (Style A/C)

The procedure below applies to single HIGH intensity operation. It would be similar if the single intensity were MED or LOW.

- Open the cover of the MCU and set the interlock switch (SW101) to the Service Position (pull up).
- Turn the LOW and MED potentiometers on PCB102 fully counter-clockwise (CCW).
- Turn the HIGH potentiometer fully clockwise (CW).
- Set the Mode Switch (SW102) on the Control Module to REM.
- Set the CCR to Step 5.
- Adjust the LOW pot on PCB102 slowly CW until the adjacent LED turns on.
 - >The HIGH LED on PCB102 should also illuminate.
 - >The MED LED on PCB102 should remain off.
 - >The HIGH LED on PCB101 should begin to blink, and flashing at HIGH intensity should begin.
- Set the CCR to Step 4.
 - >The HIGH & MED LEDs on PCB102 should turn off.
 - >The mode indicating LEDs on PCB101 should be off.

Re-adjust the LOW potentiometer on PCB102 for the turn-off condition if necessary.

TROUBLESHOOTING

Problems addressed in this section fall into two broad categories: Those encountered upon initial turn-on following installation, and evolving problems that occur after the system has been operating properly for any length of time. The most common problem that will likely be encountered is a failure to flash. This could involve either one, or both Optical Heads.

A. Problems occurring at installation

The most common problems occurring when a system is first turned on are failure to flash at all, and Remote Control problems.

1. Failure to Flash.

- a. No power (24 Vdc) to the LSM board, PCB101.
 - Check the green status LED on PS101. If the LED is lit, but no LEDs are lit on PCB101, check the F101 fuse on the Control Bracket.
- b. No power at one of the Optical Assemblies.
 - Check for dc voltage within the associated Junction Box. Verify that there is 48 to 50 Vdc on the TB201 terminal block marked "+48V in each of the Junction Boxes.
- c. Improper Comm line hookup.
 - Check both Comm lines to verify that Comm-A in the MCU (TB102) goes to Comm-A in the respective remote Junction Box (TB201), and that Comm-B similarly goes to Comm-B.

2. Remote Control Problem

The system fails to respond to remote control commands or responds incorrectly.

- Be sure the Mode Selector Switch is set to the REM position.
- Verify the set up procedure for this installation.

B. Evolving Problems

The manifestation of an evolving could be a failure of one or both heads to flash.

When flashing has been shut down due to a serious malfunction the system will override the shutdown briefly upon cycling primary power. This enables one to evaluate the cause by directly viewing each of the heads, as power is re-applied.

- Choose the MAINT MODE position on the Mode Selector Switch. In this mode the heads operate at a low level of steady illumination that is suitable for direct viewing. One can quickly ascertain which head has created the malfunction either by not lighting at all, or by having many LEDs that do not turn on.
- If none of the LEDs in one of the heads are operating check the power supply in that head's Junction Box. Look for 48 Vdc between the Blue and White wires (48 Vdc) at TB201. If there is no dc voltage at those terminals verify that current is flowing at either terminal L1 or L2. With input current flowing then either the diode bridge or power supply could be defective. Check for current from the diode bridge to the power supply to determine if either is defective.
- If the dc voltage checks OK then the problem could be in the Comm cable or connections.
- If dc voltage is present and the LEDs are on (steady mode), but a portion of the array is unlit the problem resides within the head. Contact Customer Service at SAL Technology if this condition has been ascertained.

MAINTENANCE

The following tips will help assure long, reliable operation.

- Keep door and cover seals in good condition. Repair or replace any that are damaged.
- Inspect and maintain grounding at each emplacement.
- Keep earth grounds separate from any counterpoise conductor.
- Be sure there is no free air exchange between an in-ground chamber and the MCU.
- Be sure there is no free air exchange between an in-ground chamber and a Junction Box.
- Periodically check the tightness of terminal block clamping screws.
- Inspect the flexible conduit between the Optical Heads and associated Junction Boxes
- Repair or replace any damaged conduit or fitting.

REPLACEABLE PARTS

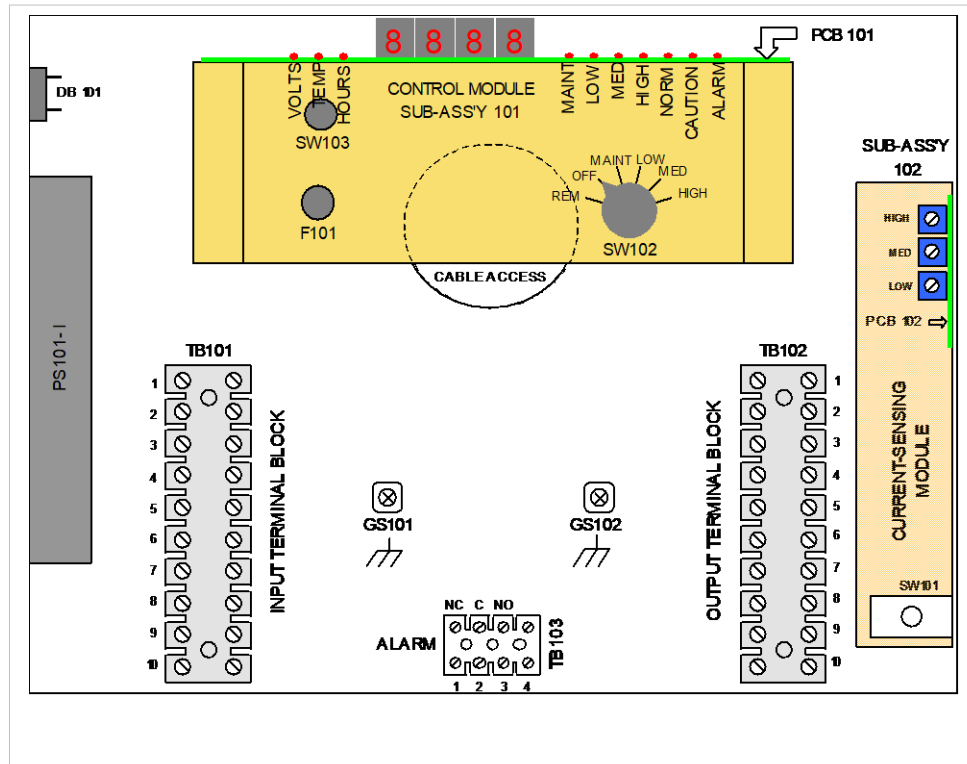

Figure 12
Component Location Diagram

Table 1, Replaceable Parts

REF	DESCRIPTION	PN
DB101	Diode Bridge	44-00174
F101	Fuse, 1.5A	55-00267
GDT	Gas Discharge Tube	44-00177
PS 101-I	24 Vdc Power supply	44-00175
PS 201-I	50 Vdc Power Supply (located in Junction Boxes)	44-00176
PCB-101	Printed Circuit Board, LSM-I	344-30105-I
PCB-301	Printed Circuit Board, CSM	255-20086
SW101	Interlock Switch	55-00201
FH 1030	Flash Head	344-40520

ADDENDUM A

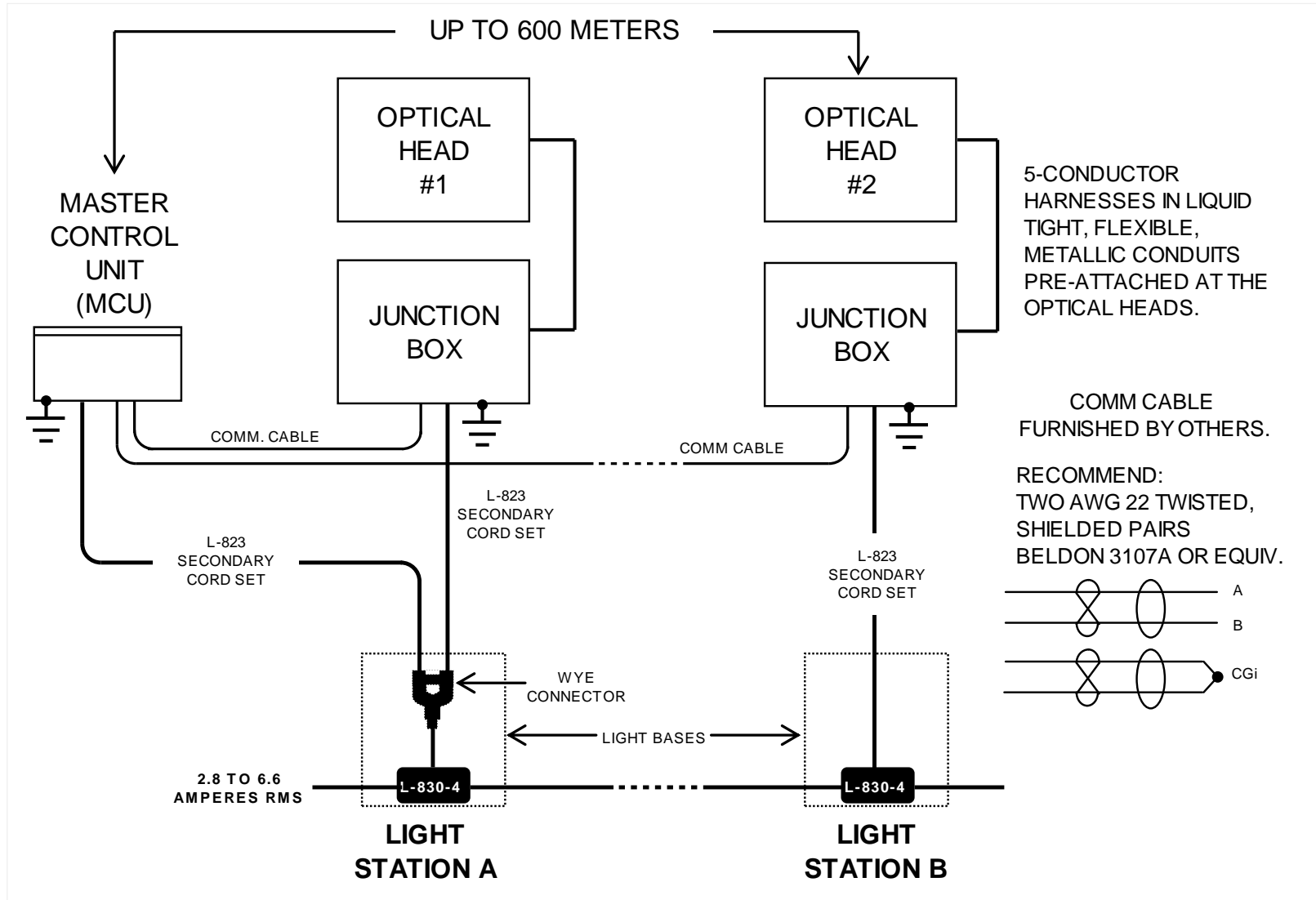

Figure A-1
System Configuration

ADDENDUM A

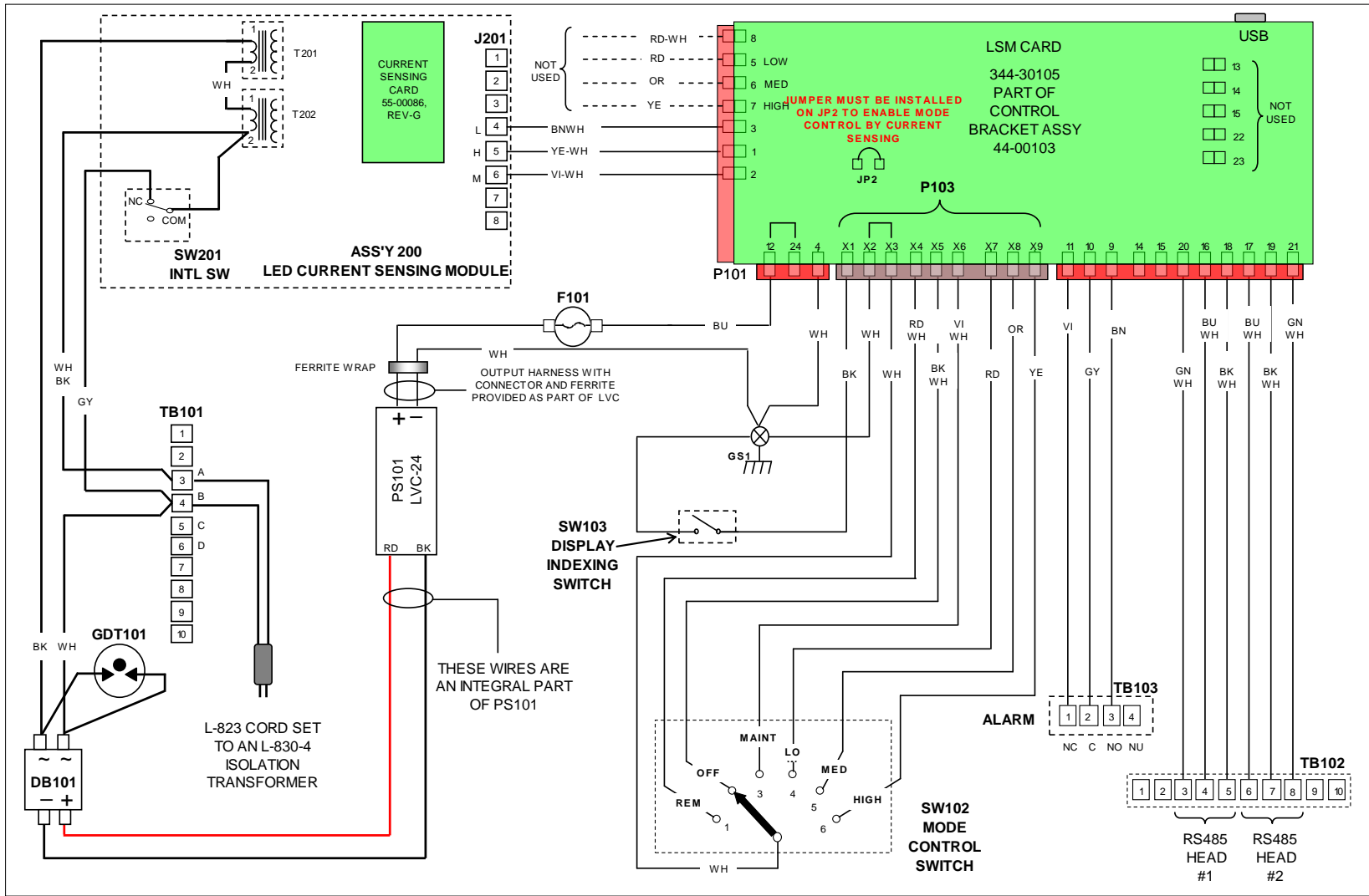

Figure A-2
MCU Wiring

ADDENDUM A

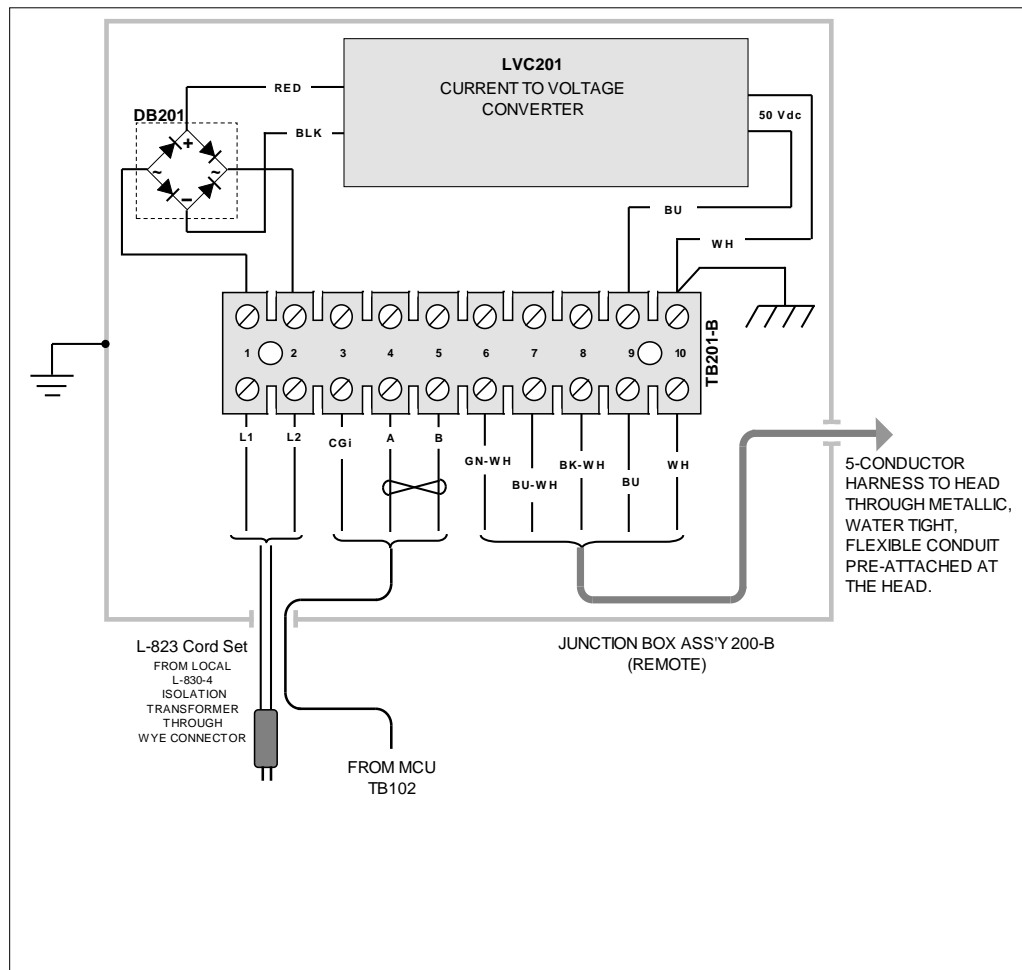

Figure A-3
 Junction Box Wiring Diagram
 For Station A (Co-located with MCU)

ADDENDUM A

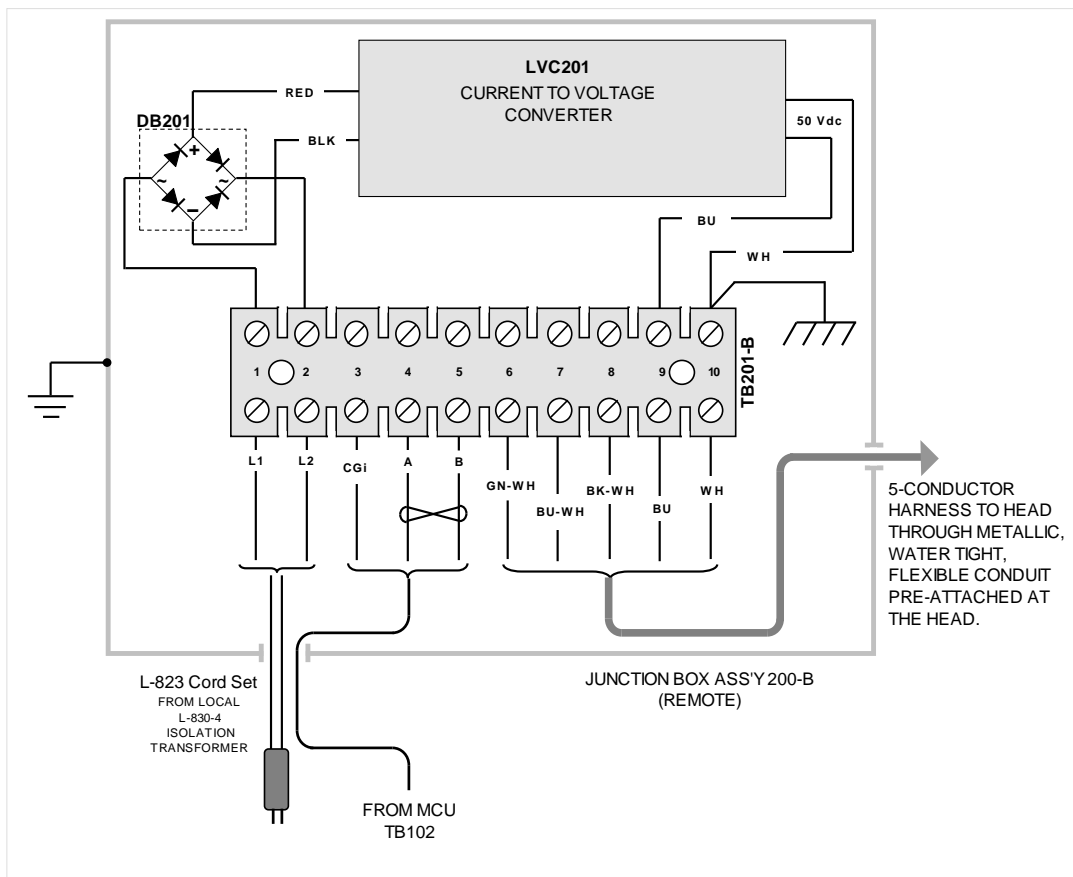

Figure A-4
Junction Box Wiring Diagram
For Station-B

ADDENDUM A

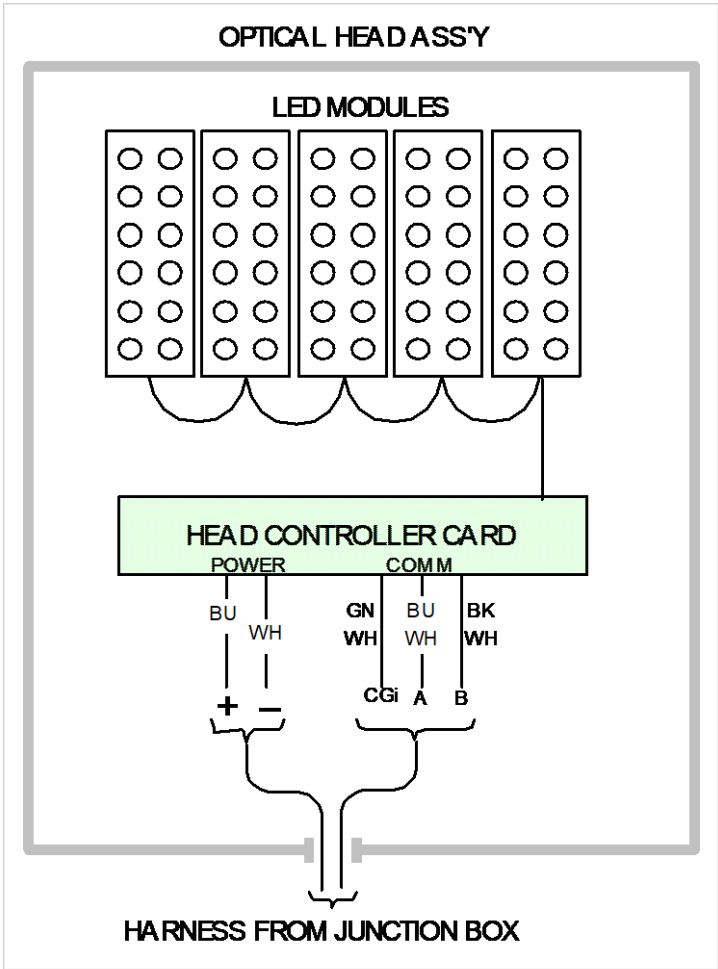

Figure A-5
Head Assembly
PN 34430520